

TAV.242		Struttura	Structure	Structure	Struktur	FEC065/FEMD065-066	FGC065/FGMD065-066
	Codice	Denominazione	Denominaton	Denominaton	Bezeichnung		
1	GAFOC00155	Porta forno	Porte du four	Oven door	Ofentür	×	×
2	GAFOC00030	Cerniera superiore porta	Charnière supérieure	Upper door hinge	Linke Türangel	×	×
3	GAFOC00157	Cerniera inferiore porta	Charnière inférieure	Lower door hinge	Untere Türangel	×	×
4	MPGOM03P00	Guarnizione vetro porta	Guarniture verre porte	Oven door glass gasket	Türdichtung	×	×
5	RTBF800021	Gommino porta	Bouchon en caoutchouc	Rubber cap	Türgummi	×	×
6	RTFOC00008	Cristallo porta forno	Verre porte four	Oven door glass	Ofentürglas	×	×
7	GAFOC00166	Controporta forno	Contre porte du four	Oven counter door	Gegentür	×	×
8	GAFOC00164	Cassetto	Tiroir	Drawer	Kasten	×	×
9	RTFOC00414	Guarnizione porta forno	Garniture porte du four	Oven door gasket	Türdichtung	×	×
10	PAFOC00329	Disco copriforo	Disque	Disk	Scheibe	×	×
11	PAFOC00410	Cruscotto	Panneau de contrôle	Control panel	Stirnbrett	×	×
12	RTFOC00413	Piedino inox	Pied inox	Inox foot	Inox-Fuß	×	×
13	PAFOC00416	Fianco destro	Côté droite	Right side	Rechte Seite	×	×
14	GAFOC00163	Coperchio	Couvercle	Cover	Topfdeckel	×	
14	GAFOC00159	Coperchio	Couvercle	Cover	Topfdeckel	×	×
15	PAFOC00410	Cruscotto	Panneau de contrôle	Control panel	Stirnbrett	×	×
16	PAFOC00418	Fianco sinistro	Côté gauche	Left side	Linke Seite	×	×
17	PAFOC00329	Disco scarico condensa	Disque évacuation condensation	Moisture drain dik	Scheibe	×	×
18	MPGOM03P00	Guarnizione	Garniture	Gasket	Dichtung	×	×
19	RTFOC00415	Asta trasversale scarico condensa	Antenne transversale évacuation cond.	Transverse rod moisture drain	Querstange	×	×
20	RTFOC00412	Asta anteriore scarico coindensa	Antenne avant évacuation cond.	Front rod moisture drain	Vordere Stange	×	×
21	RTFOC00392	Manopola scarico condens	Manette évacuation cond.	Moisture drain knob	Drehknopf Kondenswasserablass	×	×
22	RTFOC00403	Serratura porta forno	Serrure porte four	Oven door lock	Ofentürschloß	×	×
23	RTFOC00454	Distanziale serratura	Entretoise serrure	Lock spacer	Abstandstück	×	×
24	PAFOC00411	Supporto serratura	Support serrure	Lock support	Halterungschloß	×	×
25	RTFOC00035	Microinterruttore	Microswitch	Microswitch	Microswitch	×	×
26	RTFOC00036	Portalampada	Douille	Lamp-holder	Leuchtenhalterung	×	×
27	RTFOC00037	Lampada 25 W 230 V	Ampoule 25W 230V	Lamp 25W 230V	Leuchte 25W 230V	×	×
28	RTFOC00201	Vetro portalampada	Verre protège ampoule	Lamp-holder glass	Leuchtenhalterungsglass	×	×
29	RTFOC00202	Guarnizione portalampada	Garniture douille	Lamp-holder gasket	Dichtung	×	×
30	AFC0000090	Camino antivento	Cheminée antirefuleur	Chimney	Schornstein	×	×

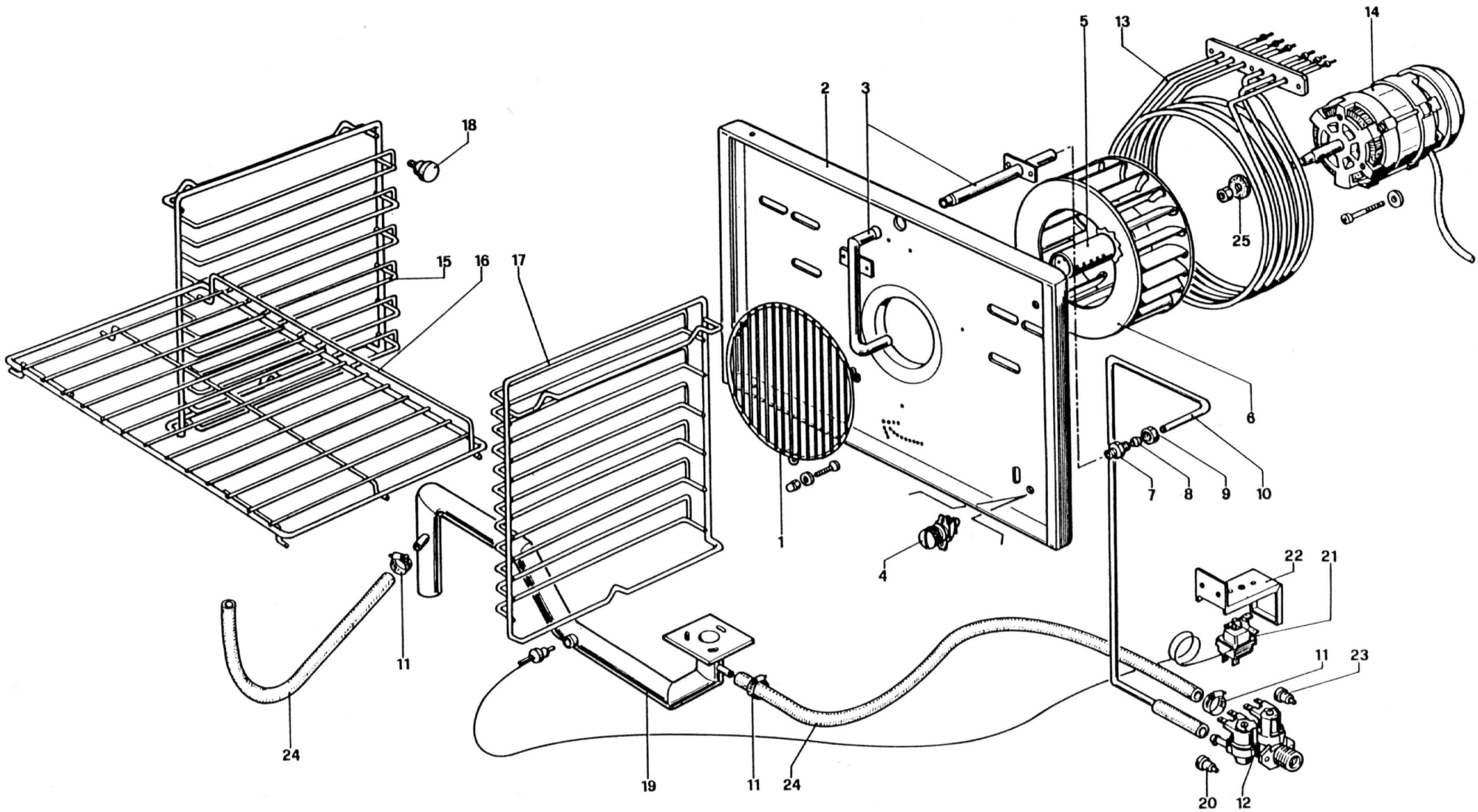

TAV.243		Griglie e ventilazione	Grilles et ventilation	Grilles and ventilation	Gitter und Belüftung	FEC065	FEMD065/066
Codice	Denominazione	Denominaton	Denominaton	Bezeichnung			
1	RTFOC00174	Griglia protezione ventilatore	Grille ventilateur	Fan grille	Ventilatorgitter	×	×
2	PAFOC00393	Convogliatore aria	Coiffée ventilateur air	Air duct	Luftförderer	×	×
3	RTFOC00408	Umidificatore	Humidificateur	Humidifier	Befeuchter	×	×
4	RTFOC00334	Attacco rapido	Attaque rapide	Quick connection	Schluss	×	×
5	RTFOC00437	Nebulizzatore	Nébulisateur	Atomizer	Zersträuber	×	×
6	RTFOC00012	Girante ventilatore	Couronne mobile ventilateur	Fan wheel	Ventilatorlaufrad	×	×
7	RTFOC00019	Iniettore umidificatore	Injecteur humidificateur	Injecteur for humidifier	Einspritzer für Befeuchter	×	×
8	RTCU800183	Bicone Ø 6	Bicone pour tube Ø 6	Bicone for pipe Ø 6	Zweikegel Ø 6	×	×
9	RTFOC00020	Calotta Ø 6	Ecron pour tube Ø 6	Nut for pipe Ø 6	Mutter für Schlauch Ø 6	×	×
10	RTFOC00409	Tube alimentazione umidif.	Tube alimentazion	Feeding pipe	Versorgungsrohr	×	×
11	RTMIN00221	Fascetta Ø 14-22	Collier Ø 14-22	Clamp Ø 14-22	Windel Ø 14-22	×	×
12	RTFOC00203	Elettrovalvola 2 vie	Electrovanne 2 voies	Solenoid valve 2 ways	E-Ventil	×	×
13	RTFOC00433	Resistenza elettr. 7,5KW 230V	Resistance elect. 7500W 240V	Over heating elect. 7500W 240V	Elektr. Widerstand 7500W 240V	×	×
15	RTFOC00011	Motor elettrico	Moteur électrique	Electric motor	E-Motor	×	×
15	RTFOC00425	Griglia laterale sinistra	Grille latérale gauche	Left lateral grate	Linker Seitenrost	×	
16	RTFOC00417	Griglia laterale sinistra	Grille latérale gauche	Left lateral grate	Linker Seitenrost		×
16	RTFOC00017	Griglia forno	Grille du four	Oven grate	Ofenrost	×	
16	RTFOC00175	Griglia forno	Grille du four	Oven grate	Ofenrost		×
17	RTFOC00424	Griglia laterale destra	Grille letérale droite	Right lateral grate	Rechter Seitenrost	×	
17	RTFOC00416	Griglia laterale destra	Grille latérale droite	Right lateral grate	Rechter Seitenrost		×
18	RTCU70002	Attacco griglia laterale	Attaque latérale	Lateral connection	Seitenanschluss	×	×
19	RTFOC00410	Rampa scarico condensa	Rampe évacuation condensation	Moisture drain ramp	Kondenswasserablassrampe	×	×
20	RTFOC00145	Regolatore elettrovalvola Ø 1,2	Regulateur elettrovanne Ø 1,2	Solenoid valve regulator Ø 1,2	E-Ventil Regler Ø 1,2	×	×
21	RTFOC00275	Termostato elettrico	Thermostat	Thermostat	Thermostat	×	×
22	PACP800062	Squadretta portatermostato	Équerre de fixation thermostat	Bracket to fix thermostat	Winkel	×	×
23	RTFOC00120	Regolatore elettrovalvola Ø 0,25	Regulateur elettrovanne Ø 0,25	Solenoid valve regulator Ø 0,25	E-Ventil Regler Ø 0,25	×	×
24	MPGOM10T00	Tube gomma Ø 10x17	Tuyau Ø 10x17	Pipe Ø 10x17	Rohr Ø 10x17	×	×
25	RTFOC00302	Anello tenuta albero motore	Garniture	Gasket	Dichtung	×	×

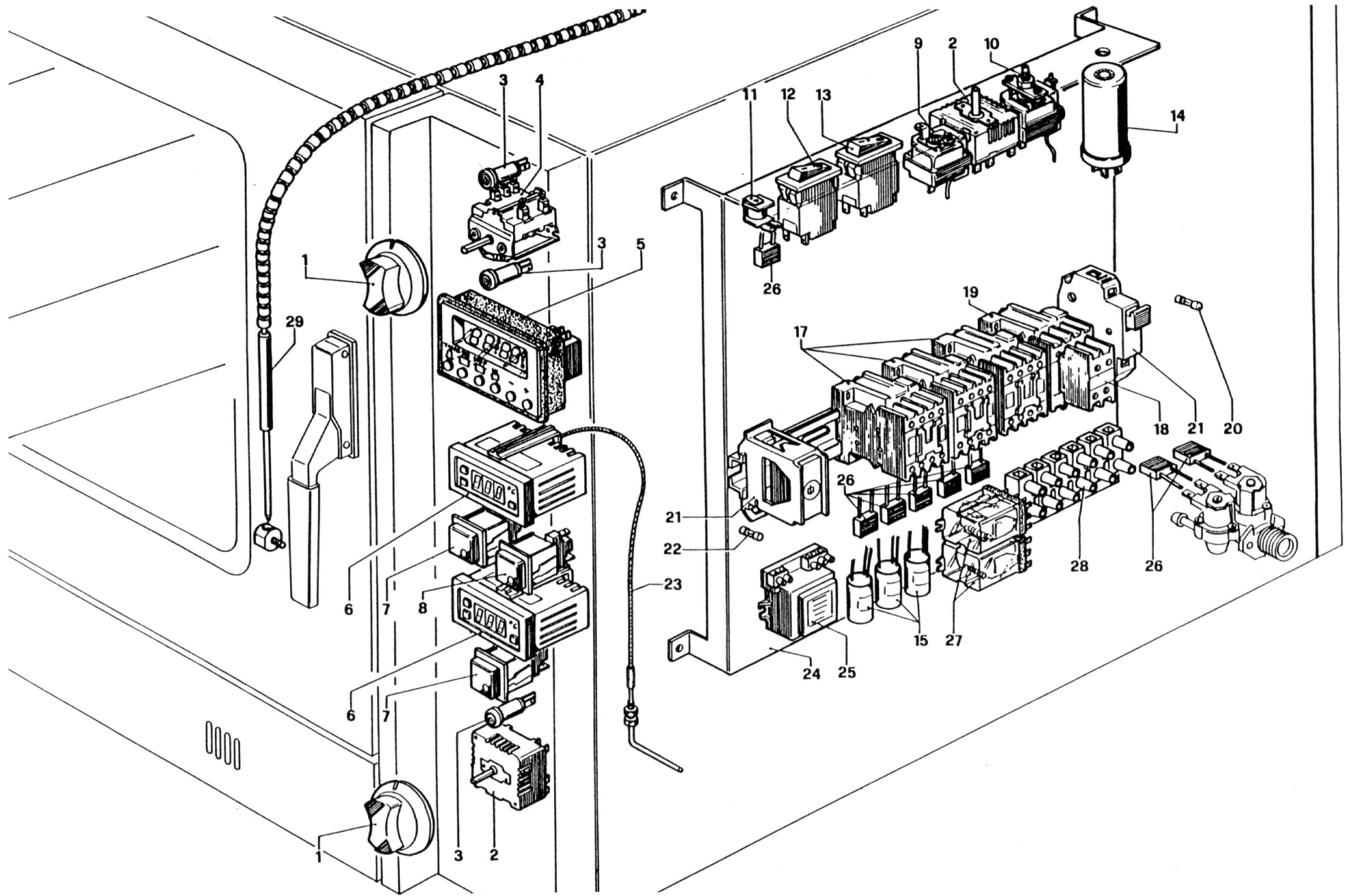

TAV.245		Apparecchiature elettriche	Appareillages électriques	Electrical equipment	Elektrogeräte	FEMD065	FEMD066
	Codice	Denominazione	Denominaton	Denominaton	Bezeichnung		
1	RTFOC00055	Manopola comando	Manette de commande	Control knob	Steuerdrehknopf	×	×
2	RTCU800066	Regolatore d'energia	Régulateur d'énergie	Power regulator	Energie Regler	×	×
3	RTCU900072	Lampada spia gialla	Lampe témoin jaune	Yellow warning lamp	Gelbe Kontrolleuchtenbirne	×	×
4	RTFOC00143	Commutatore	Commutateur du four	Oven commutator	Kommutator	×	×
5	RTFOC00405	Timer elettronico	Timer électronique	Electronic timer	Elektra-Timer	×	×
6	RTFOC00029	Termostato elettronica	Thermostat électronique	Electronic thermostat	Elektra-Thermostat	×	×
7	RTFOC00362	Pulsante 2 velocità	Bouton 2 vitesses	Two-speed button	Taste zwei geschwind	×	×
8	RTFOC00387	Pulsante luce	Bouton lumière	Light button	Lichttaste	×	×
9	RTFOC00300	Termostato	Thermostat	Thermostat	Thermostat	×	×
10	RTFOC00038	Termostato Limit	Thermostat Limit	Limit thermostat	Limit Thermostat	×	×
11	RTFOC00046	Ronzatore	Bourdonneur	Buzzer	Summer	×	×
12	RTFOC00044	Termica 0,8A	Interrupteur thermique 0,8A	Overload switch 0,8A	Thermoschutzschalter 0,8A	×	×
13	RTFOC00045	Termica 3A	Interrupteur thermique 3A	Overload switch 3A	Thermoschutzschalter 3A	×	×
14	RTFOC00053	Condensatore	Condensateur	Condenser	Kondensator	×	×
15	RTFOC00312	Antidisturbo radio	Antiparasitage radio	Antijamming	Funkentstörung	×	×
16	RTFOC00042	Ciclatore 50Hz	Cycleur 50Hz	Buzzer 50 Hz	Taktvorrichtung 50Hz	×	×
17	RTFOC00438	Relais FCV	Relais FCV	Relais FCV	Relais FCV	×	×
18	RTFOC00440	Contatti ausilari	Contacts auxiliaires	Auxiliary contacts	Nebenkontakte	×	×
19	RTFOC00439	Relais	Relais	Relais	Relais	×	×
20	RTFOC00284	Fusibile 6,3A	Fusibile 6,3A	Fuse 6,3A	Schmelzsicherung 6,3A	×	×
21	RTFOC00048	Portafusibile	Porte-fusibile	Fuse-holder	Sicherungschalter	×	×
22	RTFOC00047	Fusibile 0,1A	Fusibile 0,1A	Fuse 0,1A	Schmelzsicherung 0,1A	×	×
23	RTFOC00321	Termocopia 60	Thermocouple 60	Thermocouple 60	Thermoelement 60	×	×
24	PAFOC00029	Supporto componenti elettrici	Support composants électriques	Electrical components support	Halterung elektrischer Komponenten	×	×
25	RTFOC00039	Transformatore 220/12V	Transformateur el. 220/12V	Electric transformer 220/12V	Transformato 220/12V	×	×
26	RTFOC00023	Antidisturbo radio	Antiparasitage radio	Antijamming	Funkentstörung	×	×
27	RTFOC00144	Relais boiler	Relais bouilleur	Boiler relais	Relais	×	×
28	RTBF900045	Morsetteria 6 poli	Groupe de connec. des cables	Terminal bloc 6 poles	Klemmbreit 6 polig	×	×
29	RTFOC00130	Sonda al cuore 55 cm	Sonde thermique 55 cm	Thermic probe 55 cm	Wärmefühler 55 cm	×	×

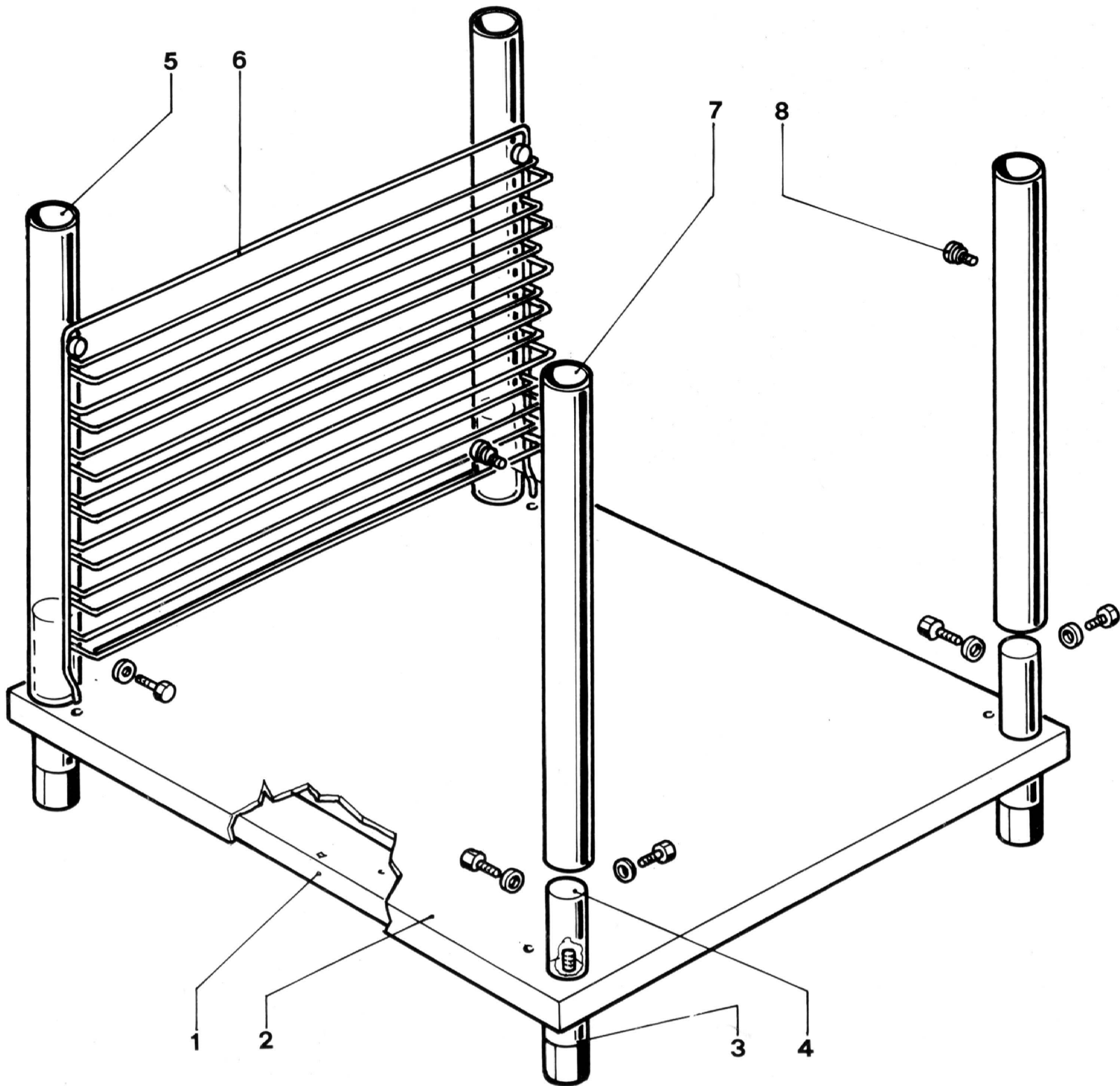

TAV.204		Supporto forno	Support du four	Oven support	Ofenhalterung	
	Codice	Denominazione	Denominaton	Denominaton	Bezeichnung	
1	GAFOC00077	Basamento supporto forno	Soubassement du support	Oven support base	Untergestell	×
2	PAFOC00133	Ripiano supporto forno	Fonde support du four	Oven support bottom	Boden	×
3	RTFOC00119	Piedino	Pied	Foot	Inox-Fuß	×
4	RTFOC00121	Rinforzo gamba	Rentort jambe	Leg bracing	Verstärkung	×
5	PAFOC00134	Gamba sinistra	Jambe gauche	Left leg	Linker Fuß	×
6	RTFOC00122	Griglia laterale	Grille latérale	Lateral grate	Seitenrost	×
7	PAFOC00135	Gamba destra	Jambe droite	Right leg	Rechter Fuß	×
8	RTBF700043	Attacco griglia	Attaque grille	Grate connection	Seitenanschluß	×