

# Shell assembly + Hydraulic circuit Mod. CB246-249-316-416-425-640-840-955-1265-1565 A/W

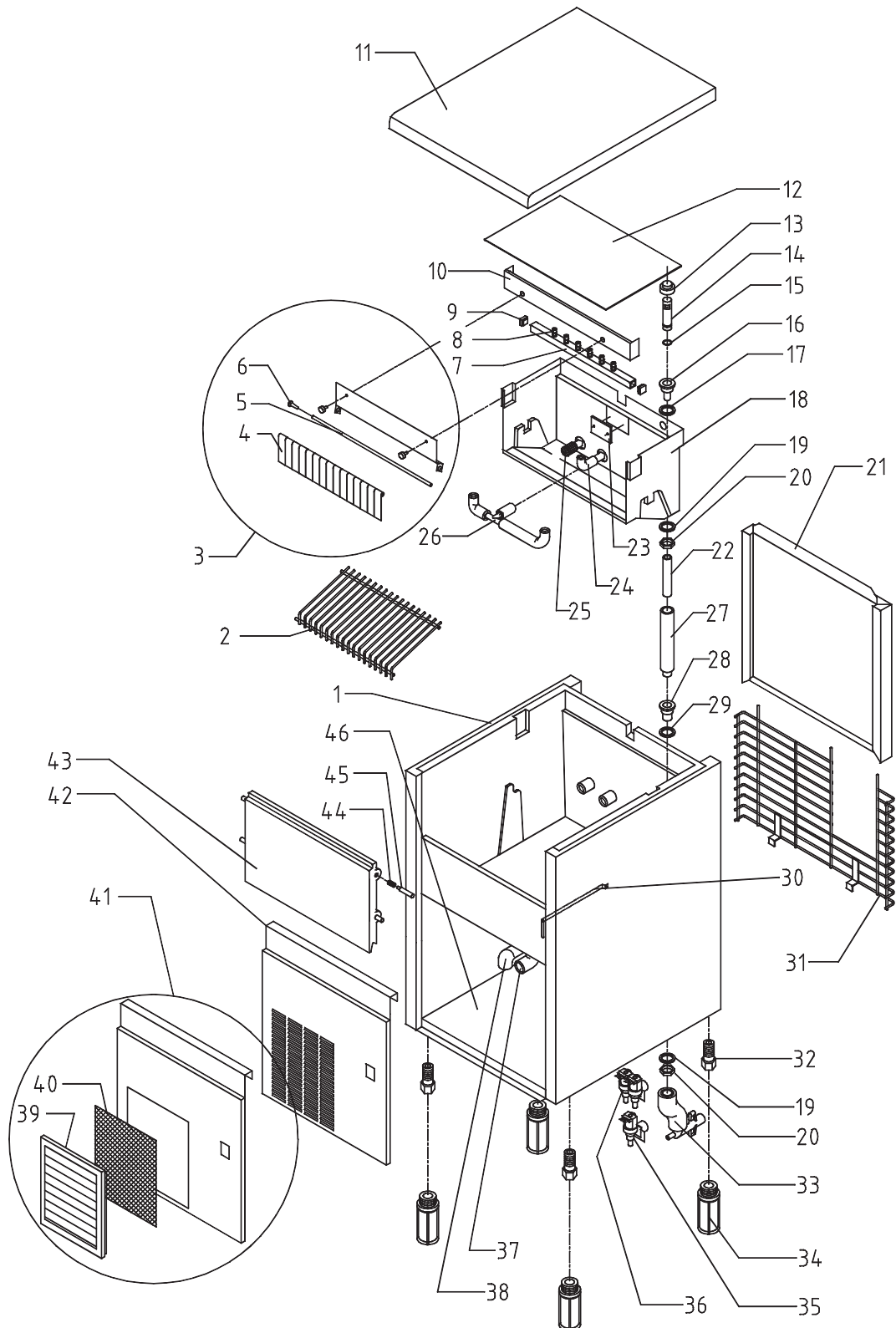

dis. 24489\_1

**Shell assembly + Hydraulic circuit Mod. CB416 A/W – (TAB. 7)**

<b>Ref.</b>	<b>Description</b>	<b>Refrigerant</b>	<b>A/W</b>	<b>Tension</b>	<b>Code</b>
1	Foamed cabinet assy				C11004
2	Ice cubes slide				D12008
3	Flags support assy				C22035
4	Flag				10005
5	Flags rod				12007
6	Flags rod clip				10010
7	Sprayers bar assembly				C20029
8	Sprayer				D20002
9	Sprayers bar plug				10012
10	Evaporator holder				22009
11	Top assembly				C22692
12	Evaporator cover				10023
13	Overflow cap				10305
14	Overflow tube				10133
15	Or gasket for overflow pipe				20233
18	Inner basin				10253
19	Semirigid polyethylene gasket				13007
20	Bin discharge nut				10096
21	Rear panel assembly				C22129
22	Overflow pipe				13107
23	Slide keep plate				10009
24	Sprayers feeding pipe				13005
25	Pump suction filter				20005
28	Plastic nipple water outlet				10007
29	Silicone gasket				13006
30	Bulb thermostat tube				20522
31	Rear grid				D12006
33	Discharges manifold		A		C10006
33	Discharges manifold		W		C26452
34	Foot h.100 mm				10040
35	Inlet watervalue 1 way		A	1-2	23001
35	Inlet watervalue 1 way		A	3	23260
36	Inlet watervalue 2 ways		W	1-2	23010
36	Inlet watervalue 2 ways		W	3	23261
37	Pump suction pipe				13013
38	Pump delivery pipe				13014
39	Grid+frame				C10205
40	Filtering panel				18106
41	Front grid panel				C22507
43	Door				10297
44	Door pin spring				20499
45	Door pin				10269
46	Base plate				21013

**Note:** 13. Code 10305 from number 64148.  
14. Code 13012 until number 64147. Code 10133 from number 64148.  
15. Code 20233 from number 64148.  
22. Code 13012 until number 64147. Code 13107 from number 64148.  
30. Code 20017 until number 94845. Code 20522 from number 94846.  
41. Code 22012 until number 29835. Code C22507 from number 29836.

---

# Cooling system assembly Mod. CB246-249-316-416-425 A/W

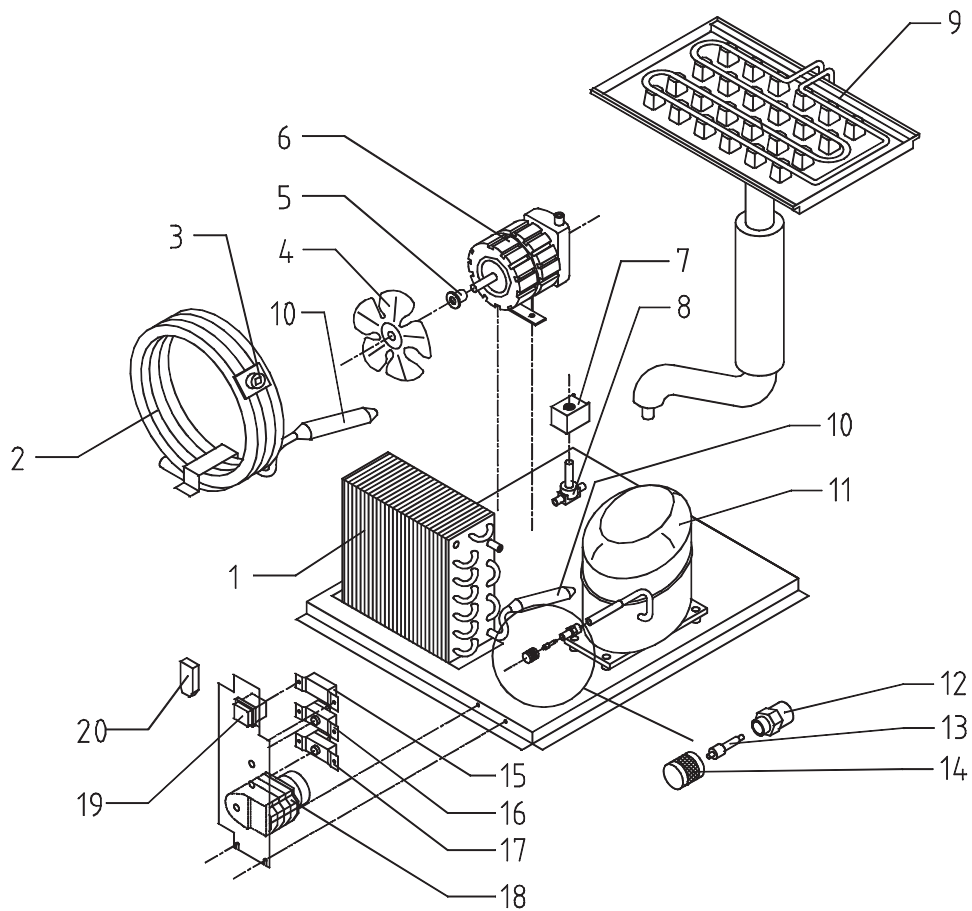

dis. 24490\_0

**Cooling system assembly Mod. CB416 A/W – (TAB. 16)**

<b>Ref.</b>	<b>Description</b>	<b>Refrigerant</b>	<b>A/W</b>	<b>Tension</b>	<b>Code</b>
1	Air condenser		A		20019
2	Water condenser		W		14014
3	Safety thermostat		W		C23114
4	Suction impeller				10213
5	Hub+washer+screw				10014
6	Pump			1-2	23002
6	Pump			3	23264
7	Hot gas coil			1-2	23091
7	Hot gas coil			3	23256
8	Hot gas valve body				20410
9	Evaporator				D10046
10	Molecular drier				14009
11	Compressor	R404A		1	23437
11	Compressor	R404A		2	23495
11	Compressor	R404A		3	23464
11	Compressor	R22		1	23320
11	Compressor	R22		2	23344
11	Compressor	R22		3	23370
12	Vacuum- charge valve body				14007
13	Vacuum-charge valve device				14005
14	Vacuum-charge valve plug				14006
15	Condenser pressure switch		W		23175
16	Bin thermostat				23005
17	Evaporator thermostat				23591
18	Timer			1	23222
18	Timer			2	23248
18	Timer			3	23259
19	Green light switch				23327
20	Anti radio interference filter		W	1	23457

**Note:** 18.Code 23222 from September 1992. Before Code 23003.