

ENTRADA GAS
PARA CONECTAR A HORNO

FUNDADA EN 1976
MASBAGA
HORNOS COCINAS

EURAST

macfrin

TOLERANCIAS GENERALES: ±0.1 mm

macfrin
group
COOKING SYSTEMS,SL

FAMILIA: COCINAS 2008

DATA:
14/07/09

MODELO: 3502

DENOMINACION:
ENCIMERA 6F 750 S.P.

ESCALA:
1/10

MATERIAL:
INOX

CODIGO:
350201M



4785/ER/11/05

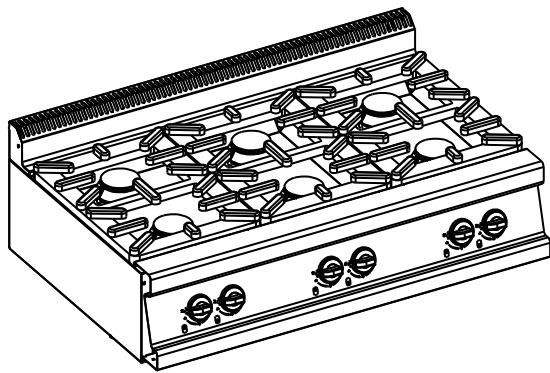

QT	COD	DESCRIPCION
4	3124	PARRILLA DOBLE
1	301501	VIERTEGRASAS 2F.400X600/750
1	330394	SOPORTE IZQ. BATERÍA
1	330401	SOBRE 4F. 600/750
1	330513	TRASERO HORNILLO 1200
1	350208	LATERAL SUPERIOR 750 DCHO
1	350209	LATERAL SUPERIOR 750 IZQ.
1	350239	FRONTAL MANDOS
1	350565	FRONTAL INFERIOR 800
6	340173PM	CONJUNTO MANDO A GAS
8	350187M	CONJUNTO QUEMADOR 6.5 KW (D)
1	350222C	CONJUNTO PETO 1200
1	350585PC	BATERIA COMPLETA COCINA 4F.
6	C5811429M	GRIFO COCINA 21-S COMPLETO
3	T06030	TUBO AL D.6 L.300
3	T06060	TUBO AL D.6 L.600
6	T10045	TUBO AL D.10 L.450

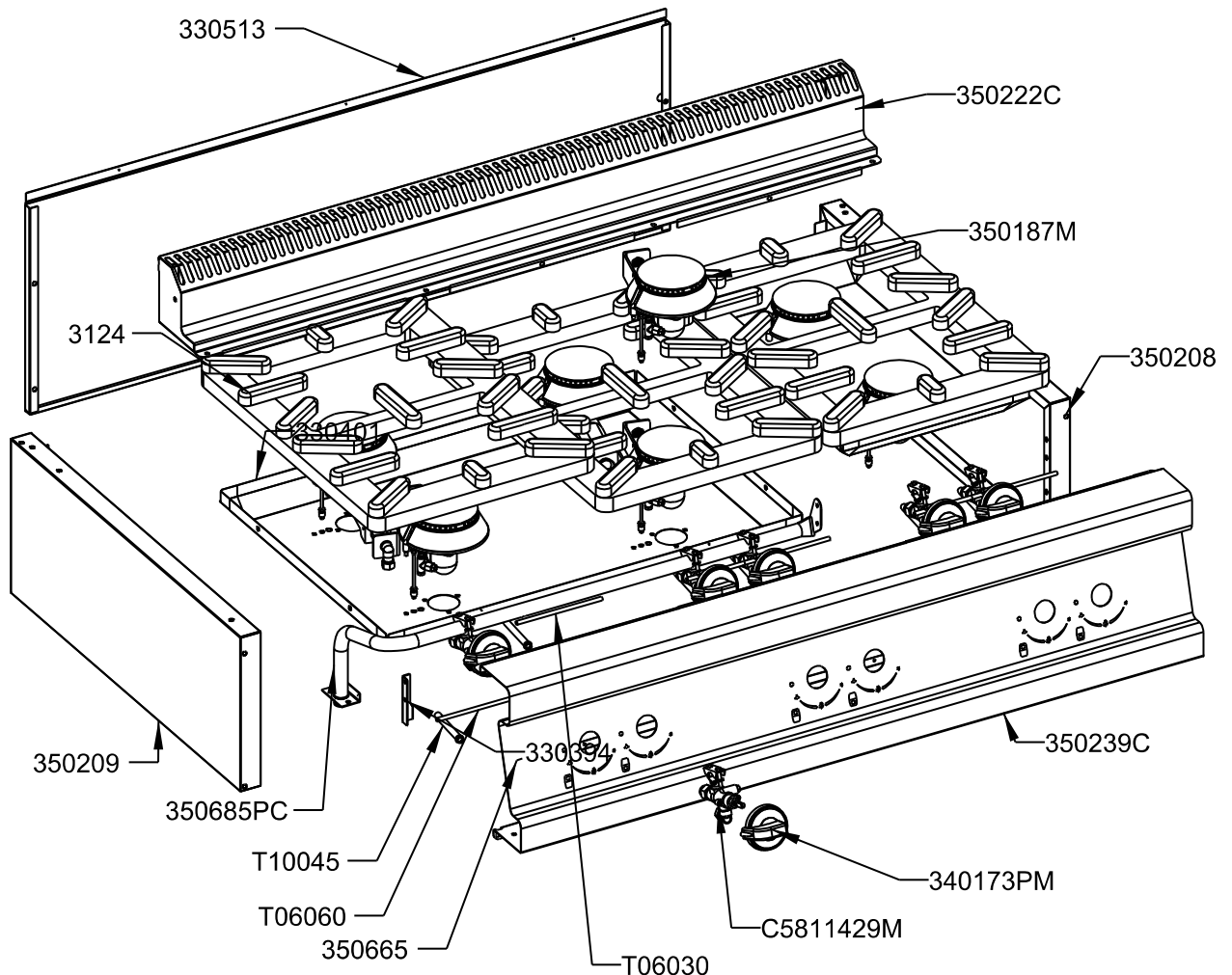

FUNDADA EN 1976
MASBAGA
HORNILLOS Y COCINAS

EURAST

macfrin

TOLERANCIAS GENERALES: ±0.1 mm

macfrin
group
COOKING SYSTEMS,SL

FAMILIA: COCINAS 2008

DATA:
14/07/09

MODELO: 3502

DENOMINACION:
ENCIMERA 6F 750 S.P.

ESCALA:
1/8

MATERIAL:
INOX

CODIGO:
350201M



926/MA/11/05



4785/ER/11/05



QT	COD	DESCRIPCION
4	3124	PARRILLA DOBLE
6	3781	TUERCA M16X1.5 D.10
6	3782	BICONO D.10 LATON
6	3810	RACORD LATON 90° M-16X1.5
1	301501	VIERTEGRASAS 2F.400X600/750
1	330194	PLETINA LATERAL BATERÍA
1	330294	PLETINA BASE BATERÍA
1	330394	SOPORTE IZQ. BATERÍA
1	330401	SOBRE 4F. 600/750
1	330513	TRASERO HORNILLO 1200
1	340178	TAPETA DERECHA PETO 750/900
1	340179	TAPETA IZQ. PETO 750/900
1	350208	LATERAL SUPERIOR 750 DCHO
1	350209	LATERAL SUPERIOR 750 IZQ.
1	350222	PETO SOBRE 1200
1	350239	FRONTAL MANDOS
1	350565	FRONTAL INFERIOR 800
6	340172P	ENVELLECEDOR MANDO GAS/ELECT.
6	340173P	MANDO COCINA GAS 2008
6	340173PM	CONJUNTO MANDO A GAS
8	350187M	CONJUNTO QUEMADOR 6.5 KW (D)
1	350201M	ENCIMERA 6F 750 S.P.
1	350222C	CONJUNTO PETO 1200
1	350585P	BATERIA 4F.
1	350585PC	BATERIA COMPLETA COCINA 4F.
6	C5811429	GRIFO VALVULA COCINA 21S D.1/2"
6	C5811429M	GRIFO COCINA 21-S COMPLETO
8	C5815079	TAPA PILOTO
8	C5815089	GUARNICION JUNTA
8	C5815099	VENTURI PILOTO
8	C5815109	CORONA DIFUSOR (D) 6.5 KW.
8	C5815119	CUERPO QUEMADOR D 6.5 KW
8	C5815129	CODO ESTANCO QUEMADOR (D)
8	C5815139	VENTURI (D) COMPLETO
8	C5815149	SOPORTE QUEMADOR HORIZONTAL
8	C5815159	PORTAINYECTOR COMPLETO
8	C5815169	CUERPO QUEMADOR PILOTO
8	C5815189	REGULADOR DE AIRE PILOTO
8	C5815209	INYECTOR GN (D) DIAM.1.50
8	C5815229	INYECTOR GLP (C) DIAM.1.05
8	C5815239	PERNO POSICIONAMIENTO
8	C5815299	TUERCA TERMOPAR M-6
8	C5815309	TERMOPAR M-9 L.400 C/M-6

FUNDADA EN 1976
MAS BAGÁ
RENDERS COCINAS**EURAST****macfrin**

TOLERANCIAS GENERALES: ±0.1 mm

COOKING SYSTEMS,SL

FAMILIA: COCINAS 2008

MODELO: 3502

DATA:
14/07/09DENOMINACION:
ENCIMERA 6F 750 S.P.ESCALA:
1/10MATERIAL:
INOXCODIGO:
350201M



926/MA/11/05



4785/ER/11/05



14	C5815359	TUERCA+BICONO D.6 M10X1
3	T06030	TUBO AL D.6 L.300
3	T06060	TUBO AL D.6 L.600
6	T10045	TUBO AL D.10 L.450
2	TESTA35	ANGULO TESTATINA 35
2	TESTA70	ANGULO TESTATINA 70



TOLERANCIAS GENERALES: ± 0.1 mm

 COOKING SYSTEMS,SL	FAMILIA: COCINAS 2008		DATA: 14/07/09
	MODELO: 3502		
DENOMINACION: ENCIMERA 6F 750 S.P.	ESCALA: 1/10	MATERIAL: INOX	CODIGO: 350201M



4785/ER/11/05

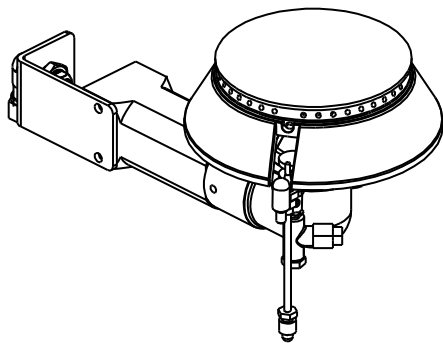

CANT.	CODIGO	DESCRIPCION
1	C5815129	CODO ESTANCO QUEMADOR (D)
1	C5815109	CORONA DIFUSOR (D) 6.5 KW.
1	C5815119	CUERPO QUEMADOR D 6.5 KW
1	C5815169	CUERPO QUEMADOR PILOTO
1	C5815089	GUARNICION JUNTA
1	C5815229	INYECTOR GLP (C) DIAM.1.05
1	C5815209	INYECTOR GN (D) DIAM.1.50
1	C5815239	PERNO POSICIONAMIENTO
1	C5815159	PORTAINYECTOR COMPLETO
1	C5815189	REGULADOR DE AIRE PILOTO
1	C5815149	SOPORTE QUEMADOR HORIZONTAL
1	C5815079	TAPA PILOTO
1	C5815309	TERMOPAR M-9 L.400 C/M-6
1	C5815299	TUERCA TERMOPAR M-6
1	C5815359	TUERCA+BICONO D.6 M10X1
1	C5815139	VENTURI (D) COMPLETO
1	C5815099	VENTURI PILOTO

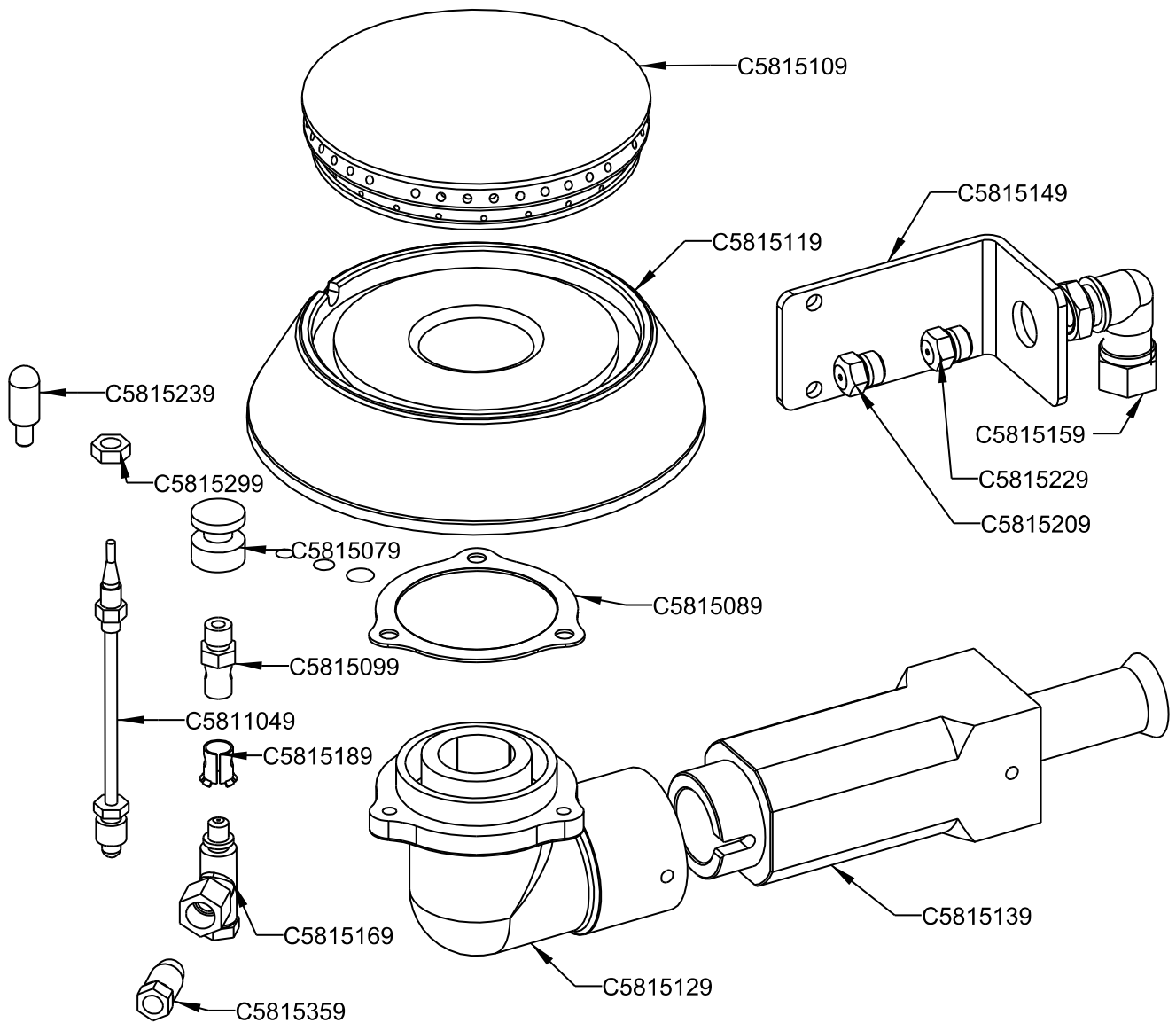

FUNDADA EN 1976
MAS BAGA
SEMPRE SOCORRIDA

EURAST

macfrin

TOLERANCIAS GENERALES: ±0.1 mm



COOKING SYSTEMS,SL

FAMILIA: COCINAS 2008

MODELO: 3501

DATA:
30/09/08

DENOMINACION:
CONJUNTO QUEMADOR 6.5 KW TIPO D

ESCALA:
1/2

MATERIAL:
FUND.

PROGRAMA:
3501-87-M



926/MA/11/05



4785/ER/11/05

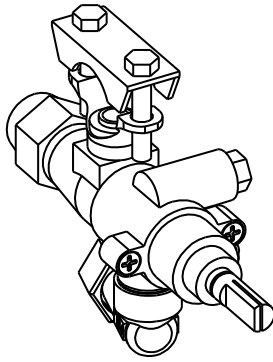

QT	COD	DESCRIPCION
1	3781	TUERCA M16X1.5 D.10
1	3782	BICONO D.10 LATON
1	3810	RACORD LATON 90° M-16X1.5
1	C5811429	GRIFO VALVULA COCINA 21S D.1/2"
1	C5815359	TUERCA+BICONO D.6 M10X1

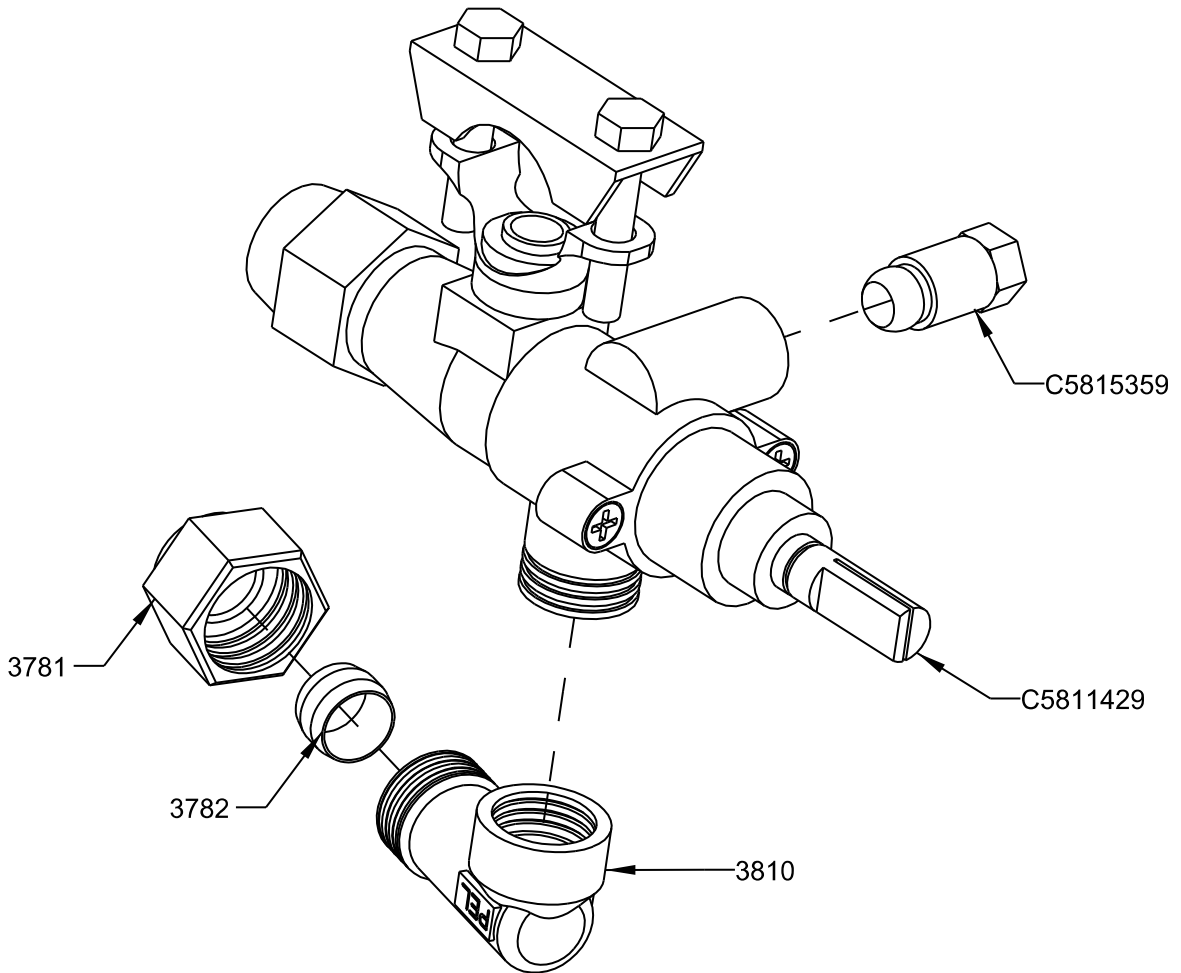

FUNDADA EN 1976
MASBAGA
SERVICIOS SOCIALES

EURAST

macfrin

TOLERANCIAS GENERALES: ±0.1 mm



COOKING SYSTEMS,SL

FAMILIA: COCINAS 2008

DATA:
05/09/08

MODELO: 3401

DENOMINACION:
GRIFO COCINA 21-S COMPLETO

ESCALA:
1/1

MATERIAL:
LATON

PROGRAMA:
C5811429M



926/MA/11/05



4785/ER/11/05

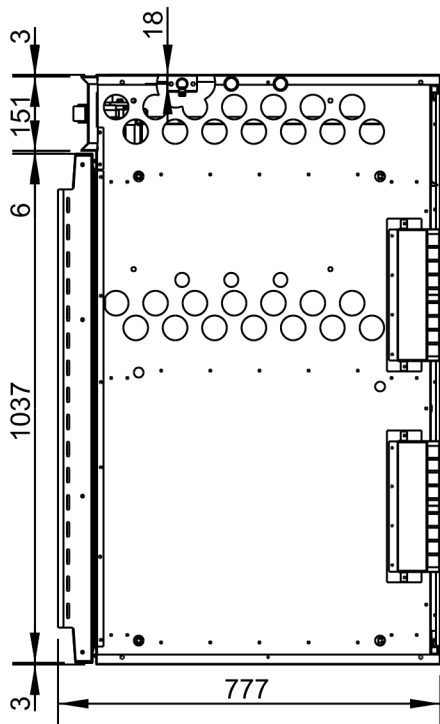
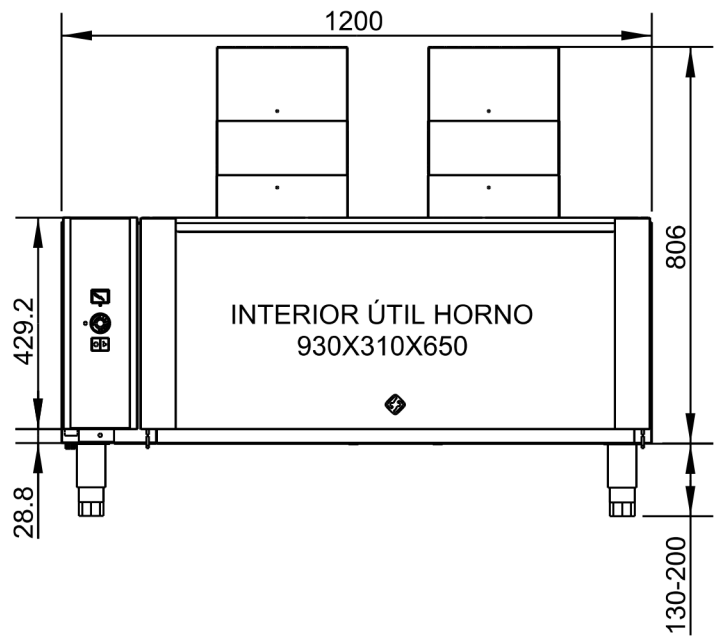
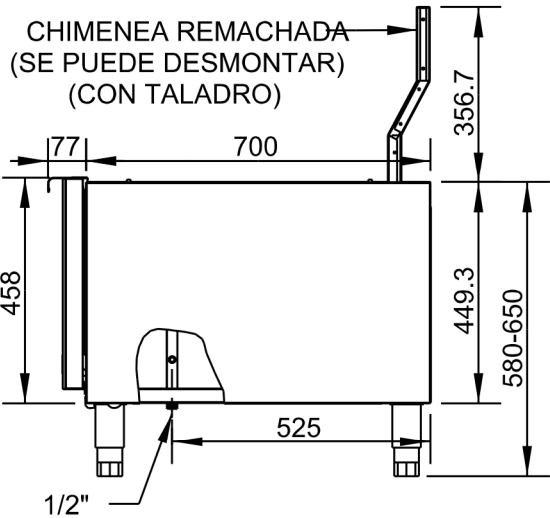

SALIDA GAS
CONEXION A APARATO
MONTADO ENCIMA

ENTRADA
GAS

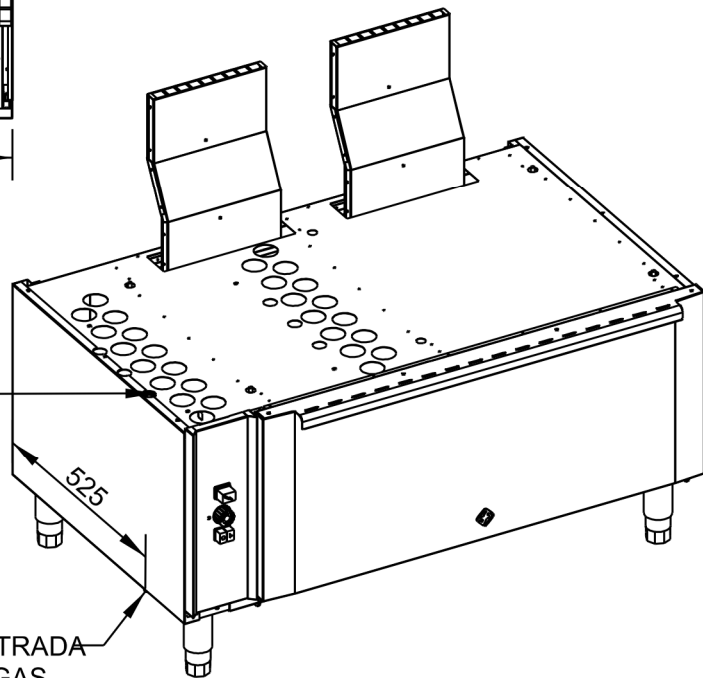

FUNDADA EN 1978
MASBAGA
REFRIGERACIONES

EURAST

macfrin

TOLERANCIAS GENERALES: ±0.1 mm

COOKING SYSTEMS,SL

FAMILIA: COCINAS 2008

MODELO: 3592 - R6L - 761GG

DATA:
14/01/09

DENOMINACION:
HORNO CHE 750

ESCALA:
1/20

MATERIAL:
INOX

CODIGO:
3592-80-M



926/MA/11/05



4785/ER/11/05

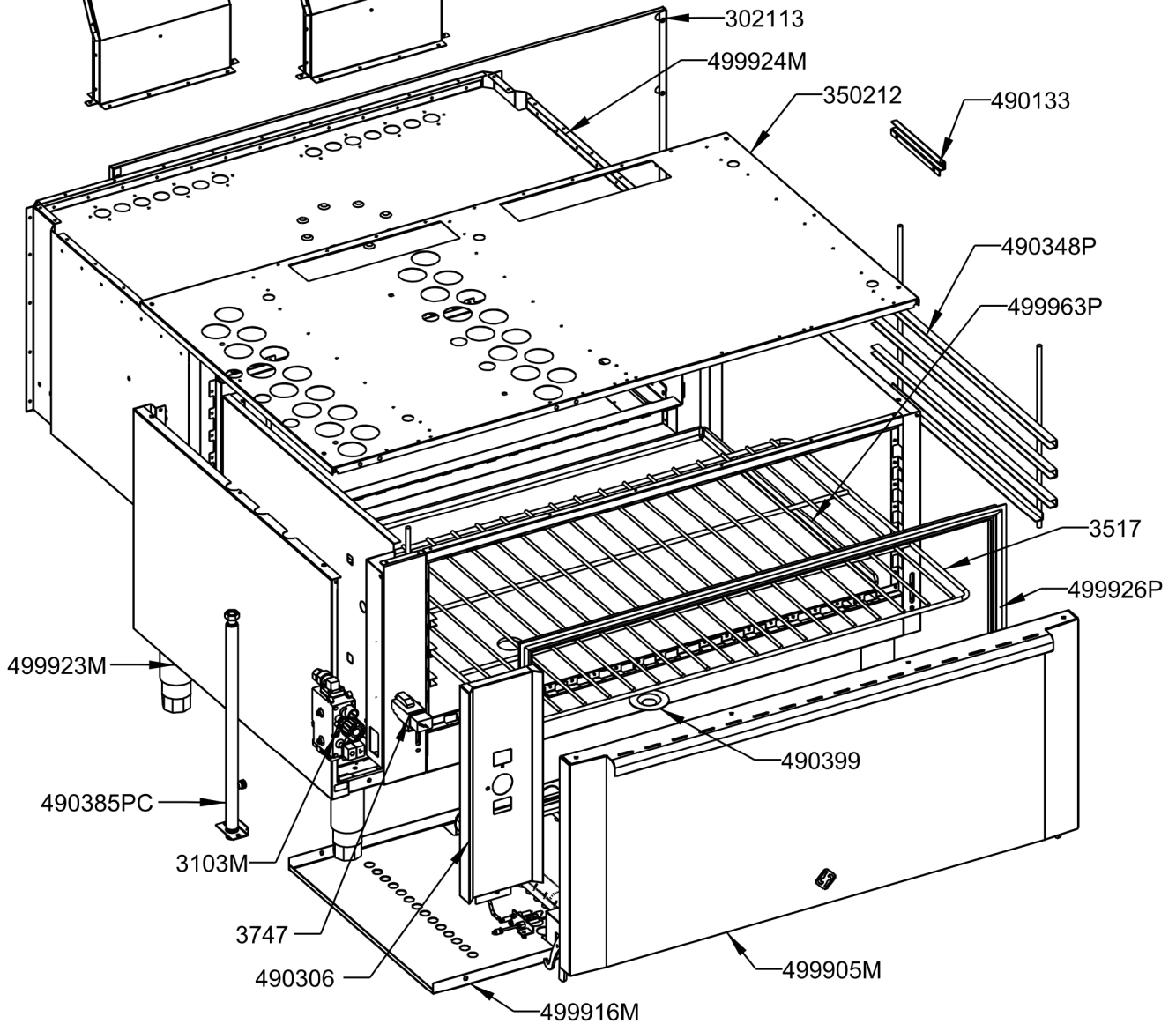
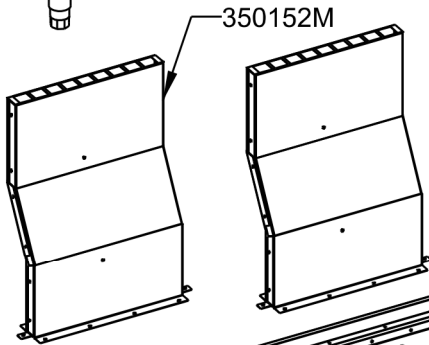
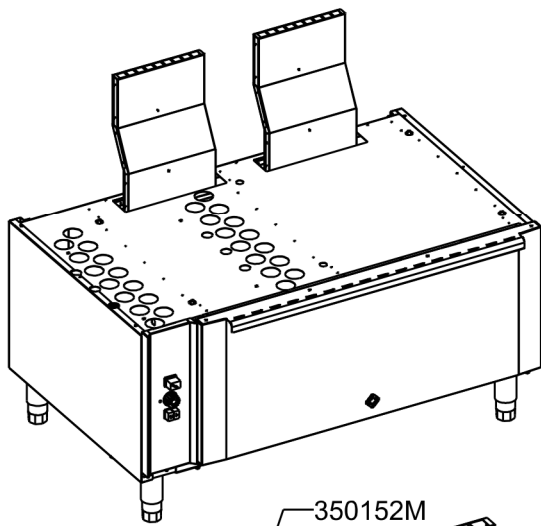

QT	COD	DESCRIPCION
1	3517	PARRILA HORNO CHE
1	3747	PIEZO ELECTRICO SIT
1	302113	TRASERO SOPORTE SNACK 1200
1	350212	TECHO HORNO 1200
1	490133	PROTECTOR BULBO
1	490306	CANTONERA HORNO GAS
1	490399	TAPA VISOR PLANCHA HORNO
1	3103M	VALVULA SIT COMPLETA
2	350152M	CONJ.SALIDA VAHOS 600-750
2	490348P	REJILLA 2/1
1	490385PC	BATERIA COMPLETA HORNO LATERAL
1	499905M	PUERTA HORNO CHE COMPLETA
1	499916M	DEFLECTOR MONTADO CHE
1	499923M	CUBA EXTERIOR HORNO CHE
1	499924M	CUBA INTERIOR HORNO CHE
1	499926P	BURLETE HORNO CHE
1	499963P	PLANCHA HORNO CHE
5	C6580169	FIBRA DE VIDRIO 40mm (m2)

FUNDADA EN 1978
MAS BAGA
SEMPRE COCINANDO

EURAST

macfrin

TOLERANCIAS GENERALES: ±0.1 mm

COOKING SYSTEMS,SL

FAMILIA: COCINAS 2008

DATA:
14/01/09

MODELO: 3592 - R6L - 761GG

DENOMINACION:
HORNO CHE 750

ESCALA:
1/10

MATERIAL:
INOX

CODIGO:
3592-80-M



926/MA/11/05



4785/ER/11/05



QT	COD	DESCRIPCION
8	1051	TORNILLO ZN M4X15 DIN 84
1	2175	CABLE PIEZO L=760
1	3103	VALVULA MINI SIT
1	3517	PARRILA HORNO CHE
1	3747	PIEZO ELECTRICO SIT
1	3765	MANDO VALV. SIT
3	3781	TUERCA M16X1.5 D.10
3	3782	BICONO D.10 LATON
2	3785	JUNTA VALVULA MINISIT
1	6160	BISAGRA HORNO DERECHA
1	6163	BISAGRA HORNO IZQUIERDA
2	61980	PORTARRULINO BISAGRA HORNO
1	300399	TAPA 20X20 C/AGUJERO D.12
1	301399	TAPA 20X20
1	302113	TRASERO SOPORTE SNACK 1200
2	330189	MANGUITO M16X1.5 TUBO D.10
1	330294	PLETINA BASE BATERÍA
2	350152	SALIDA VAHOS HORNO 600-750
2	350204	OMEGA COCINA 1200
1	350212	TECHO HORNO 1200
1	490133	PROTECTOR BULBO
1	490306	CANTONERA HORNO GAS
1	490307	AISLANTE HORNO 2/1
1	490308	LATERAL DERECHO EXT.HORNO
1	490309	LATERAL DERECHO CANTONERA
1	490324	LATERAL IZQ.HORNO 2/1
1	490325	LATERAL DCHO. HORNO 2/1
2	490348	ANGULO APOYO PLANCHA HORNO
1	490368	MONTANTE INTERMEDIO BISAGRA HORNO
2	490375	REFUERZO BISAGRA
4	490398	ANGULO DISTANCIADOR CHIMENEA
1	490399	TAPA VISOR PLANCHA HORNO
1	499905	PUERTA HORNO CHE
1	499916	DEFLECTOR HORNO CHE
1	499918	CONTRAPUERTA HORNO CHE
1	499921	TECHO HORNO CHE
1	499933	REGISTRO DOS QUEMADORES HORNO
3	499956	OMEGA REFUERZO CONTRAPUERTA CHE
1	499958	FRONTAL INFERIOR BOCA HORNO CHE
1	499959	ZOCALO INTERIOR HORNO CHE
1	499964	TRASERO HORNO CHE
1	499965	FRONTAL SUPERIOR BOCA HORNO CHE
2	300187P	QUEMADOR TUBULAR D.40 L.400

FUNDADA EN 1978
MASBAGA
SEMPRE COCINANDO

EURAST

macfrin

TOLERANCIAS GENERALES: ±0.1 mm

COOKING SYSTEMS,SL

FAMILIA: COCINAS 2008

MODELO: 3592 - R6L - 761GG

DATA:
14/01/09

DENOMINACION:
HORNO CHE 750

ESCALA:
1/10

MATERIAL:
INOX

CODIGO:
3592-80-M



926/MA/11/05



4785/ER/11/05



1	3103M	VALVULA SIT COMPLETA
2	350152M	CONJ.SALIDA VAHOS 600-750
1	359280M	HORNO CHE 750
2	362489P	MACHON D.10 - 3/8" - M16X1.5
2	490348P	REJILLA 2/1
1	490385P	BATERIA HORNO LATERAL
1	490385PC	BATERIA COMPLETA HORNO LATERAL
1	493086P	COLECTOR HGR
1	493086PC	COLECTOR 2 SALIDAS HGR
1	499905M	PUERTA HORNO CHE COMPLETA
1	499916M	DEFLECTOR MONTADO CHE
1	499918C	CONJUNTO CONTRAPUERTA HORNO CHE
1	499923M	CUBA EXTERIOR HORNO CHE
1	499924M	CUBA INTERIOR HORNO CHE
1	499926P	BURLETE HORNO CHE
1	499963P	PLANCHA HORNO CHE
1	A1018996	RACORD BUJIA
1	A1018997	RACORD PILOTO
1	A1018998	RACORD TERMOPAR
1	A1018999	BICONO PILOTO
1	C5810129	PILOTO POLIDORO
1	C5810129M	PILOTO POLIDORO COMPLETO
1	C5810139	BUJIA
1	C5810159	INYECTOR PILOTO GN (27.2) 2 AGUJ.
1	C5810169	INYECTOR PILOTO GLP (22) 1 AGUJ.
2	C5810419	CODO 90° -3/8" SIT S/R.0906252
1	C5811459	RACORD 2P. 359GLCU-COAS 14X1/2"
1	C5811829	TERMOPAR LISO M9X1 L 600
2	C5812649	INYECTOR D.110 GLP QUEMADOR L.400
2	C5812669	INYECTOR D.160 GN QUEMADOR L.400
1	C5815359	TUERCA+BICONO D.6 M10X1
4	C6260511	PATA INOX 130-200 (S_F)
6	C6580169	FIBRA DE VIDRIO 40mm (m2)

FUNDADA EN 1978
MAS BAGA
SEMPRE COCINAS**EURAST****macfrin**

TOLERANCIAS GENERALES: ±0.1 mm

COOKING SYSTEMS, SL

FAMILIA: COCINAS 2008

DATA:
14/01/09

MODELO: 3592 - R6L - 761GG

DENOMINACION:
HORNO CHE 750ESCALA:
1/10MATERIAL:
INOXCODIGO:
3592-80-M



926/MA/11/05



4785/ER/11/05

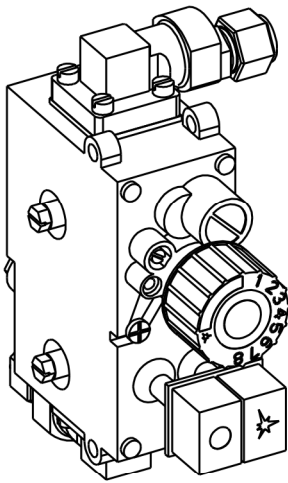

QT	COD	DESCRIPCION
8	1051	TORNILLO ZN M4X15 DIN 84
1	3103	VALVULA MINI SIT
1	3765	MANDO VALV. SIT
2	3781	TUERCA M16X1.5 D.10
2	3782	BICONO D.10 LATON
2	3785	JUNTA VALVULA MINISIT
2	362489P	MACHON D.10 - 3/8" - M16X1.5
2	C5810419	CODO 90° -3/8" SIT S/R.0906252
1	C5815359	TUERCA+BICONO D.6 M10X1

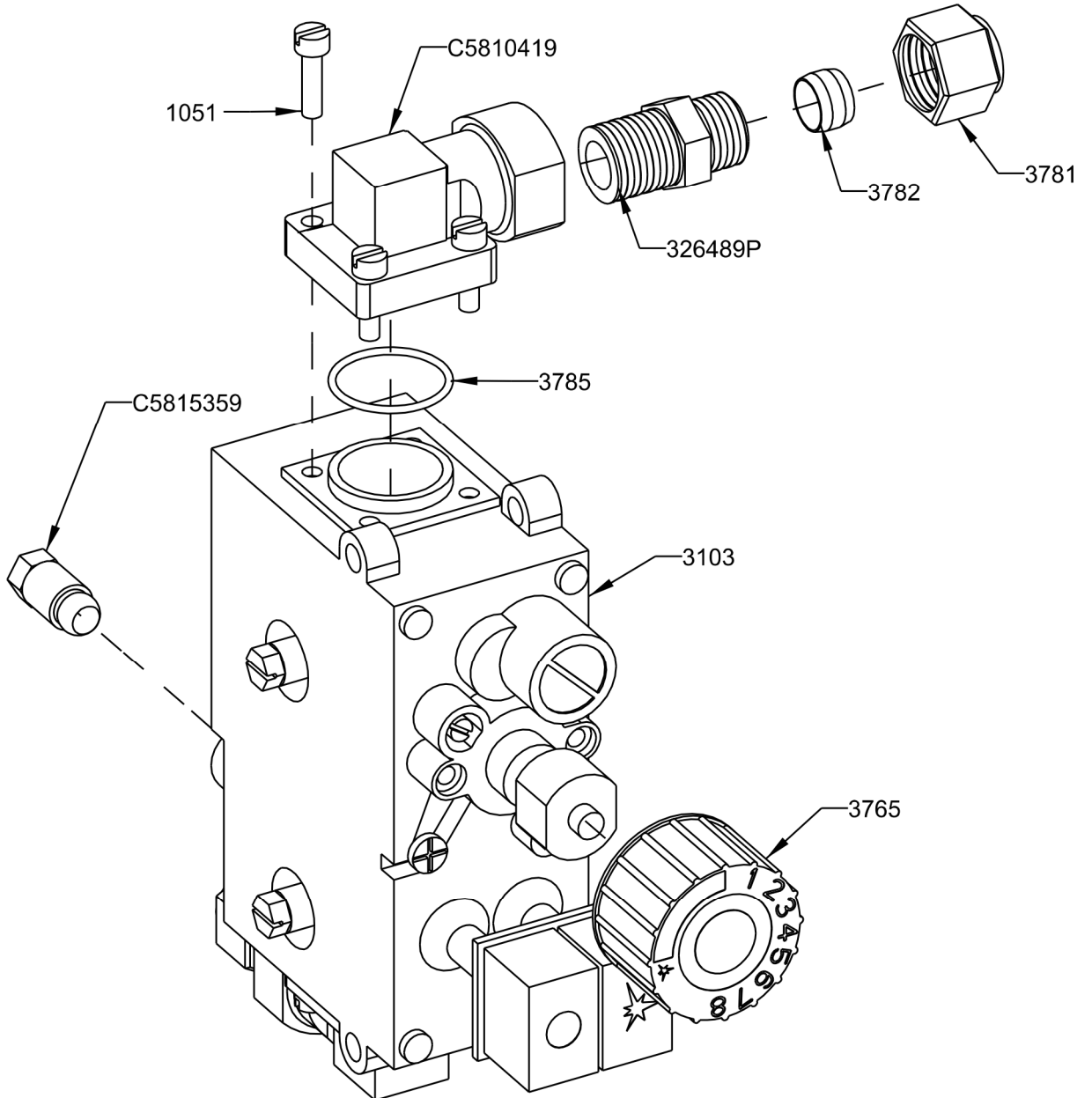

FUNDADA EN 1978
MASBAGA
SEMPRE COCINANDO

EURAST

macfrin

TOLERANCIAS GENERALES: ±0.1 mm

macfrin
group
COOKING SYSTEMS,SL

FAMILIA: COCINAS 2008

DATA:
05/09/08

MODELO: 3611

DENOMINACION:
VALVULA SIT COMPLETA

ESCALA:
1/2

MATERIAL:
AL

CODIGO:
3103M



926/MA/11/05



4785/ER/11/05



QT	COD	DESCRIPCION
1	350152	SALIDA VAHOS HORNO 600-750
2	490398	ANGULO DISTANCIADOR CHIMENEA

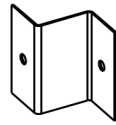
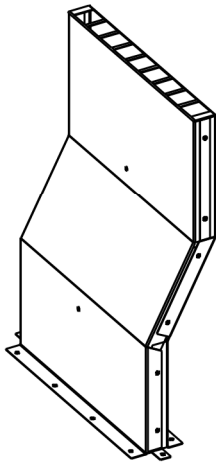

490398

350152

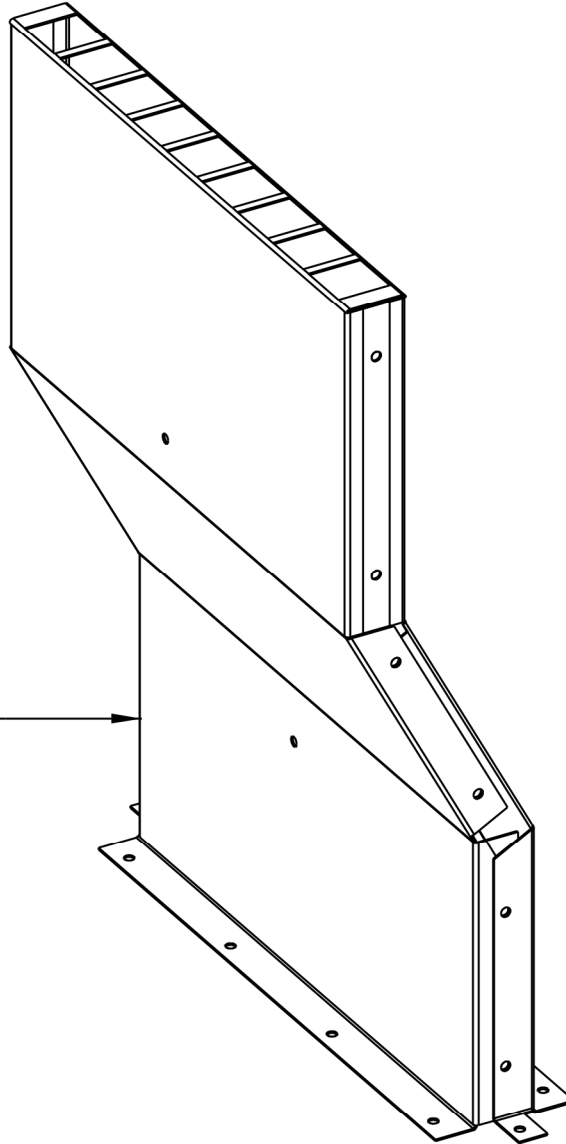

TOLERANCIAS GENERALES: ± 0.1 mm

macfrin
group
COOKING SYSTEMS,SL

FAMILIA: COCINAS 2008

MODELO: 3501

DENOMINACION:
CONJ.SALIDA VAHOS 600-750

ESCALA:
1/5

MATERIAL:
GALVA

REF.	
O.F.	
QT.	
DEST.	

DATA:
15/01/09

CODIGO:
3501-52-M



926/MA/11/05



4785/ER/11/05



QT	COD	DESCRIPCION
1	330189	MANGUITO M16X1.5 TUBO D.10
1	330294	PLETINA BASE BATERÍA
1	490385P	BATERIA HORNO LATERAL
1	C5811459	RACORD 2P. 359GLCU-COAS 14X1/2"

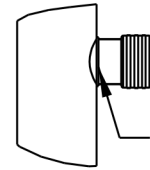
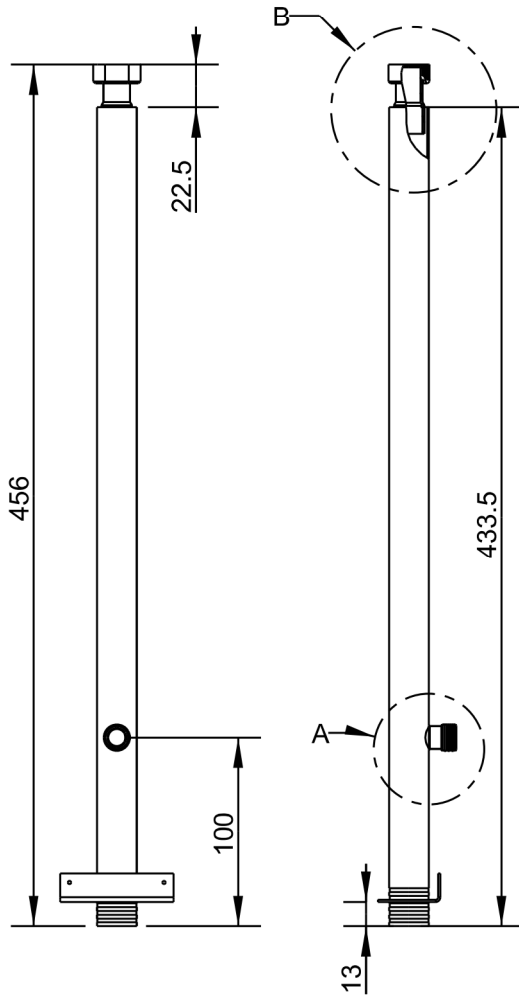

TOPE POSICIONADOR
SOLDADURA ESTANCA

DETALLE A
ESCALA 1/2

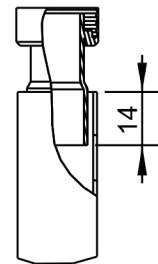

MUY IMPORTANTE
SOLDADURA CON PLATA
DETALLE B
ESCALA 1/2

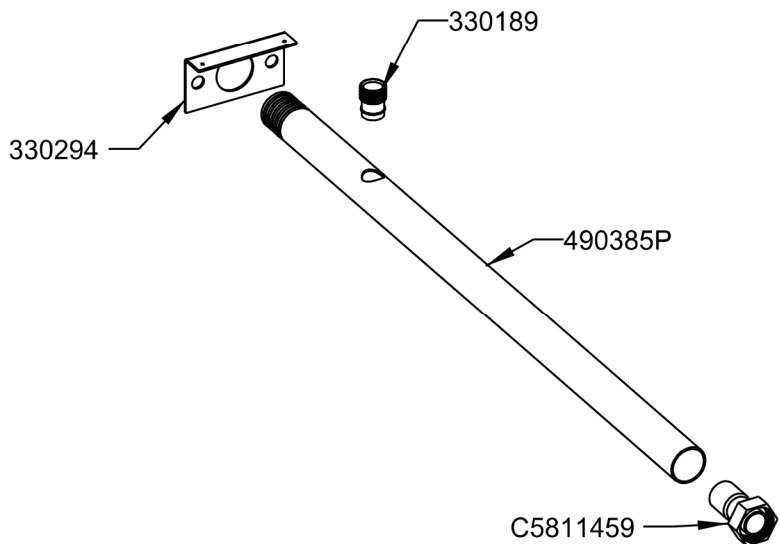
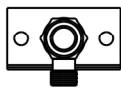

FUNDADA EN 1978
MAS BAGA
SIEMPRE COCINAS

EURAST

macfrin

TOLERANCIAS GENERALES: ±0.1 mm

macfrin
group
COOKING SYSTEMS,SL

FAMILIA: COCINAS 2008

MODELO: 4903

DATA:
11/11/08

DENOMINACION:
BATERIA COMPLETA HORNO LATERAL

ESCALA:
1/4

MATERIAL:
FE
TRATAMIENTO:
ZINCADO

PROGRAMA:
4903-85-PC



926/MA/11/05



4785/ER/11/05



QT	COD	DESCRIPCION
1	6160	BISAGRA HORNO DERECHA
1	6163	BISAGRA HORNO IZQUIERDA
1	499905	PUERTA HORNO CHE
1	499918C	CONJUNTO CONTRAPUERTA HORNO CHE
1	C6580169	FIBRA DE VIDRIO 40mm

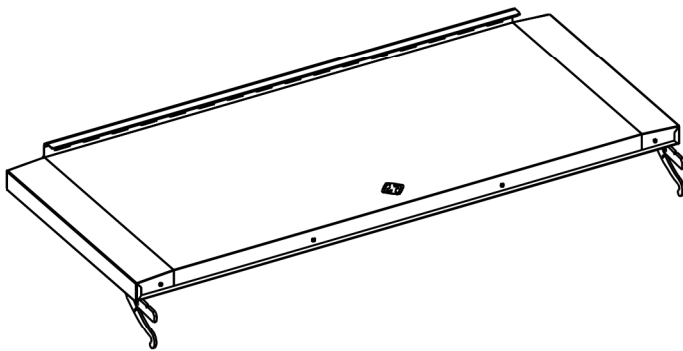
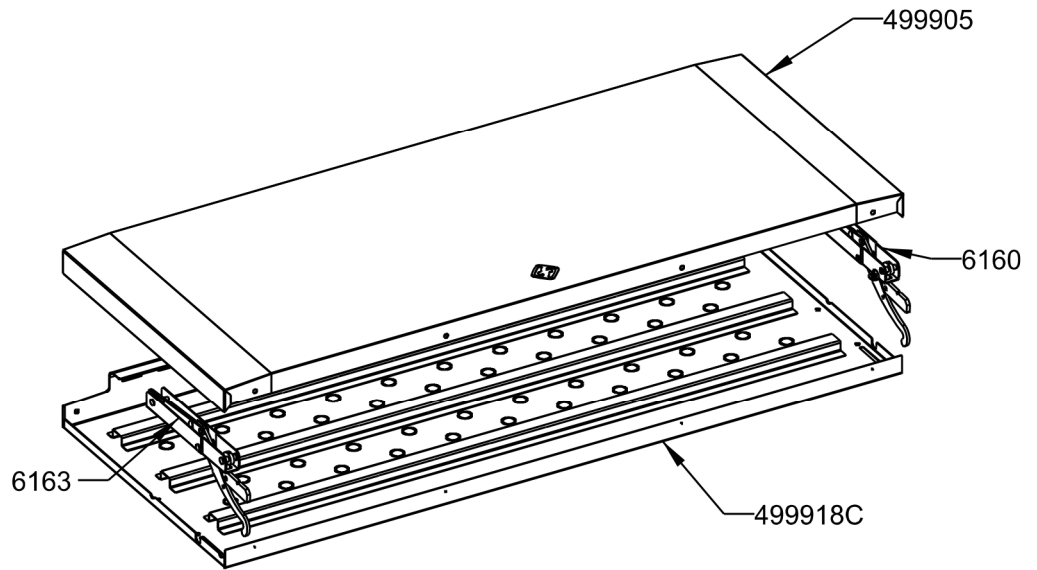
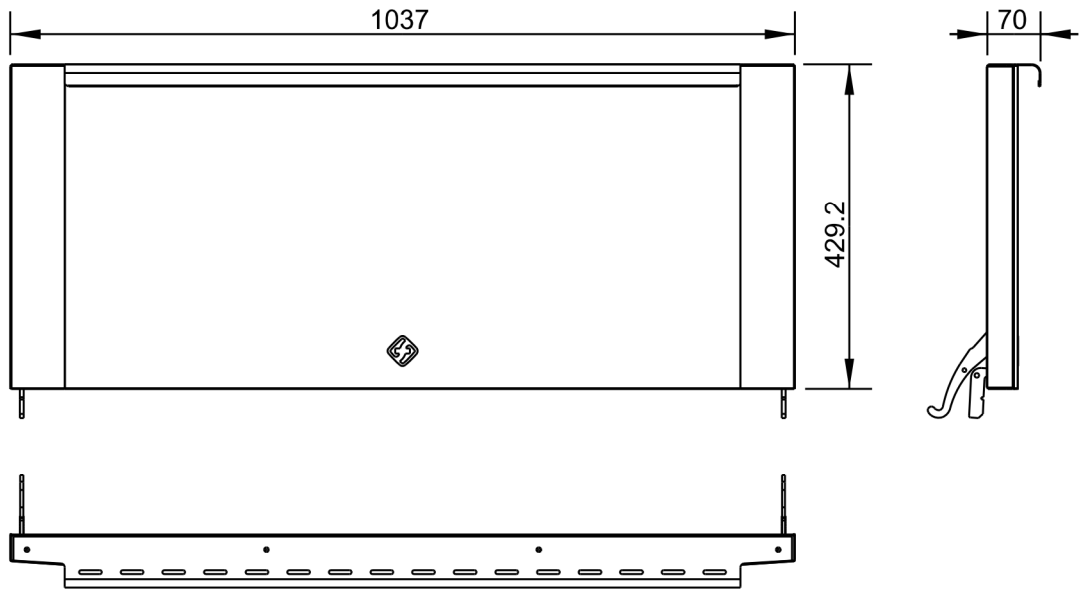

FUNDADA EN 1978
MAS BAGA
SIEMPRE COCINANDO

EURAST

macfrin

TOLERANCIAS GENERALES: ±0.1 mm

macfrin
group
COOKING SYSTEMS,SL

FAMILIA: COCINAS 2008

MODELO: 4999

REF.	
O.F.	
QT.	
DEST.	

DATA:
10/03/08

DENOMINACION:
PUERTA HORNO CHE COMPLETA

ESCALA:
1/10

MATERIAL:
INOX

PROGRAMA:
4999-05-M



926/MA/11/05



4785/ER/11/05



QT	CODIGO	DESCRIPCION
1	499918	CONTRAPUERTA HORNO CHE
3	499956	OMEGA REFUERZO CONTRAPUERTA CHE
1	499918C	CONJUNTO CONTRAPUERTA HORNO CHE

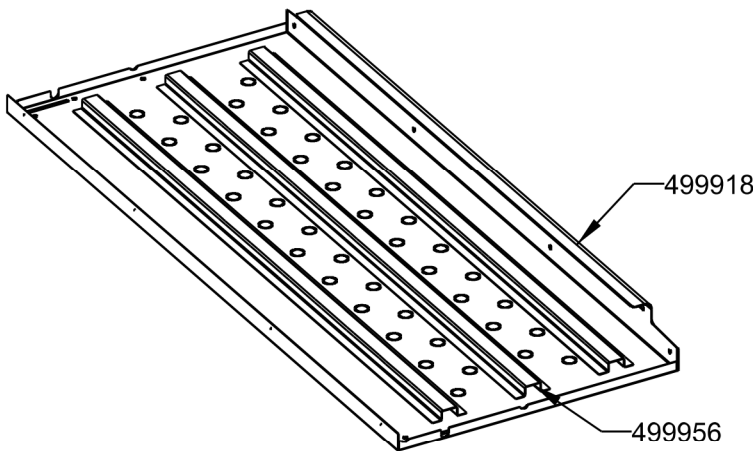
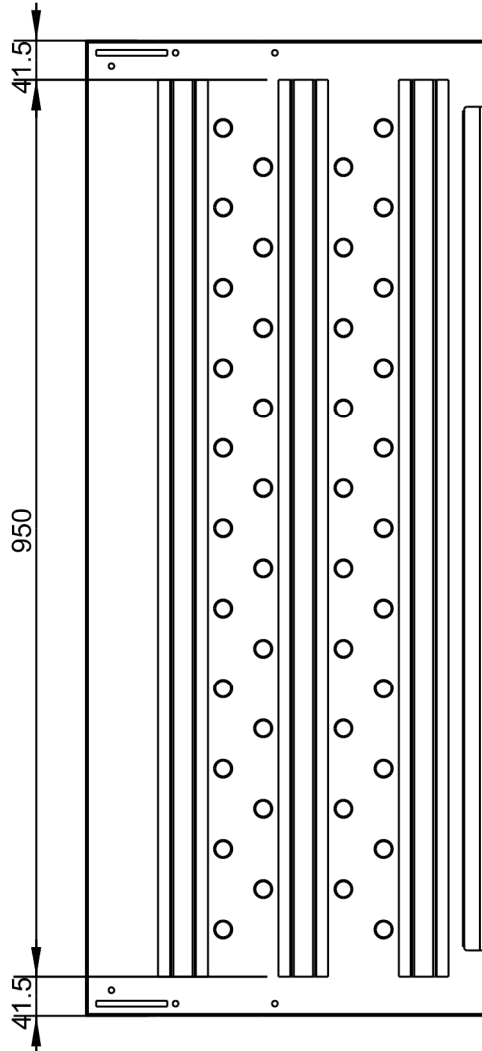
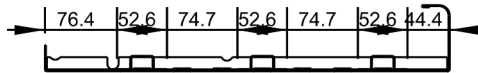

TOLERANCIAS GENERALES: ±0.1 mm

macfrin
group
COOKING SYSTEMS,SL

FAMILIA: COCINAS 2008

MODELO: 4999

REF.	
O.F.	
QT.	
DEST.	

DATA:
09/10/08

DENOMINACION:
CONJUNTO CONTRAPUERTA HORNO CHE

ESCALA:
1/8

MATERIAL:
INOFER

PROGRAMA:
4999-18-C



926/MA/11/05



4785/ER/11/05

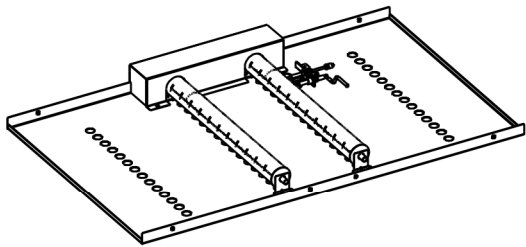

QT	COD	DESCRIPCION
1	3781	TUERCA M16X1.5 D.10
1	3782	BICONO D.10 LATON
1	499916	DEFLECTOR HORNO CHE
1	499933	REGISTRO DOS QUEMADORES HORNO
2	300187P	QUEMADOR TUBULAR D.40 L.400
1	493086PC	COLECTOR 2 SALIDAS HGR
1	C5810129M	PILOTO POLIDORO COMPLETO
2	C5812649	INYECTOR D.110 GLP QUEMADOR L.400
2	C5812669	INYECTOR D.160 GN QUEMADOR L.400

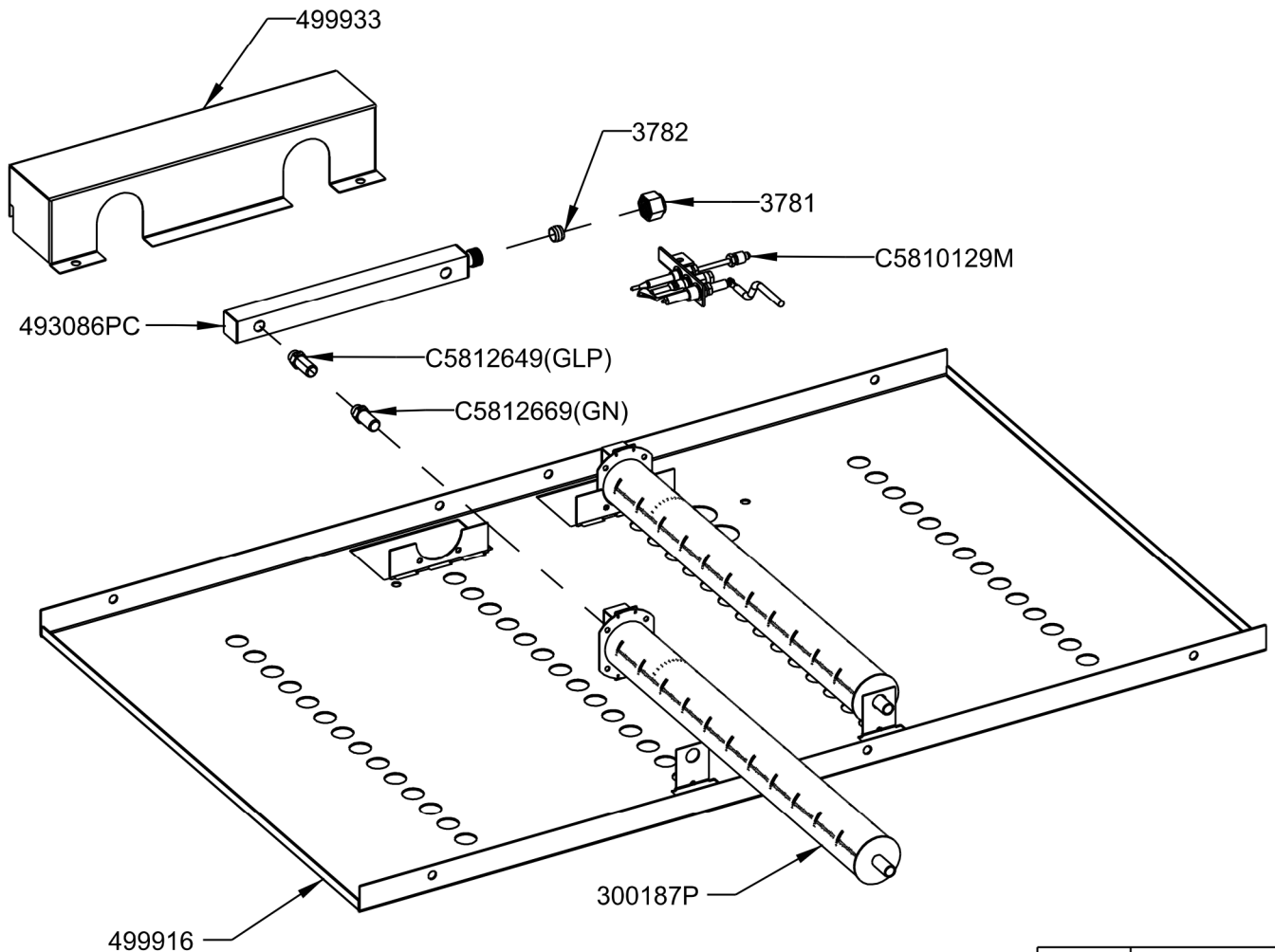

TOLERANCIAS GENERALES: ±0.1 mm



FAMILIA: COCINAS 2009

MODELO: 4999

REF.	
O.F.	
QT.	
DEST.	

DATA:
14/01/09

DENOMINACION: DEFLECTOR MONTADO CHE	ESCALA: 1/5	MATERIAL: INOX	CODIGO: 4999-16-M
--	----------------	-------------------	----------------------



926/MA/11/05



4785/ER/11/05



QT	COD	DESCRIPCION
1	300399	TAPA 20X20 C/AGUJERO D.12
1	301399	TAPA 20X20
1	330189	MANGUITO M16X1.5 TUBO D.10
1	493086P	COLECTOR HGR

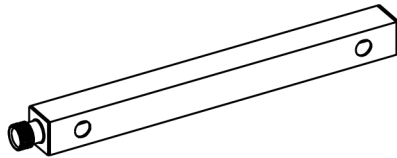

ESCALA 1/4

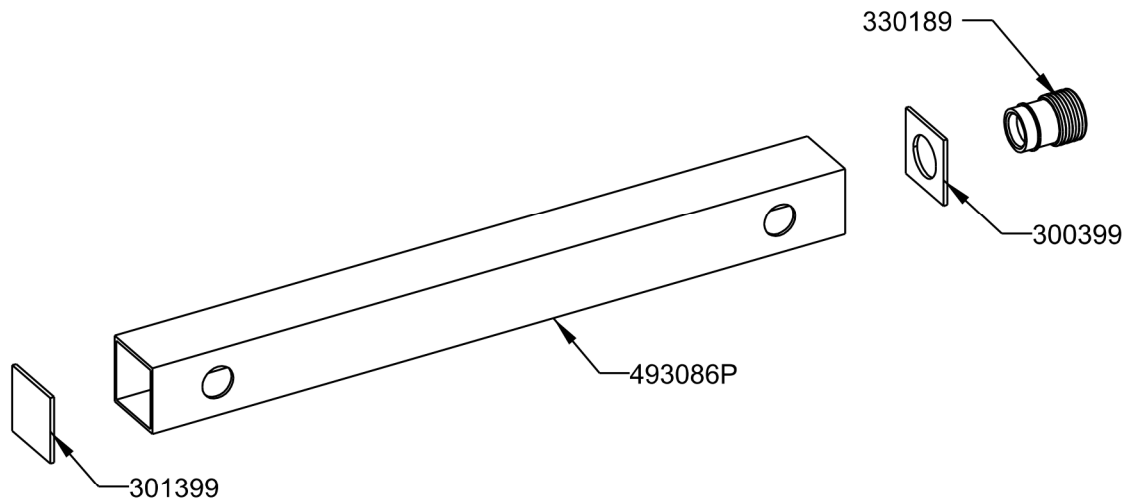
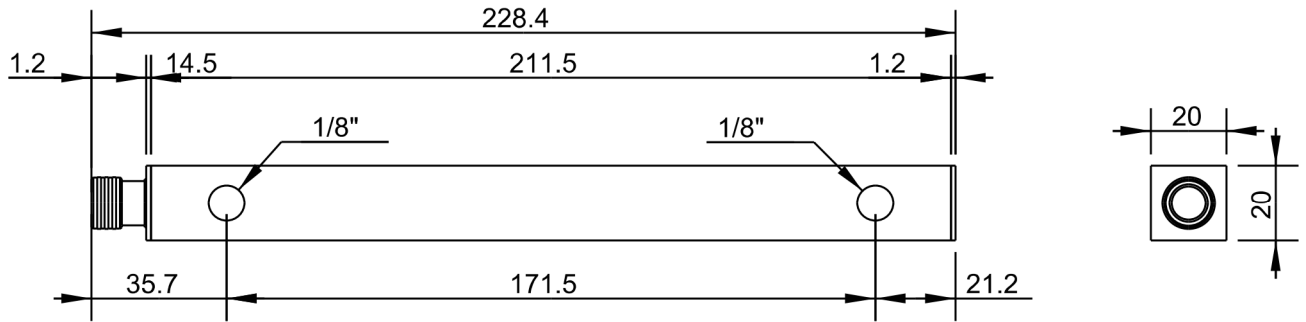

FUNDADA EN 1978
MAS BAGA
SIEMPRE COCINANDO

EURAST

macfrin

TOLERANCIAS GENERALES: ±0.1 mm

SOLDADURA CONTINUA Y ESTANCA



FAMILIA: COCINAS 2008

MODELO: 4930

REF.	
O.F.	
QT.	
DEST.	

DATA:
07/10/08

DENOMINACION:
COLECTOR 2 SALIDAS GAS HGR

ESCALA:
1/2

MATERIAL:
FE ZINCADO

PROGRAMA:
4930-86-PC



926/MA/11/05



4785/ER/11/05

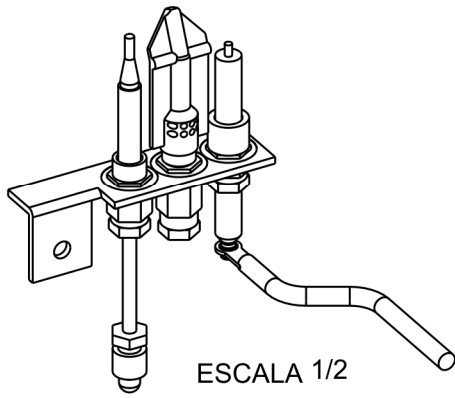

ESCALA 1/2

QT	COD	DESCRIPCION
1	2175	CABLE PIEZO L=760
1	A1018996	RACORD BUJIA
1	A1018997	RACORD PILOTO
1	A1018998	RACORD TERMOPAR
1	A1018999	BICONO PILOTO
1	C5810129	PILOTO POLIDORO
1	C5810139	BUJIA
1	C5810159	INYECTOR PILOTO GN (27.2) 2 AGUJ.
1	C5810169	INYECTOR PILOTO GLP (22) 1 AGUJ.
1	C5811829	TERMOPAR LISO M9X1 L 600

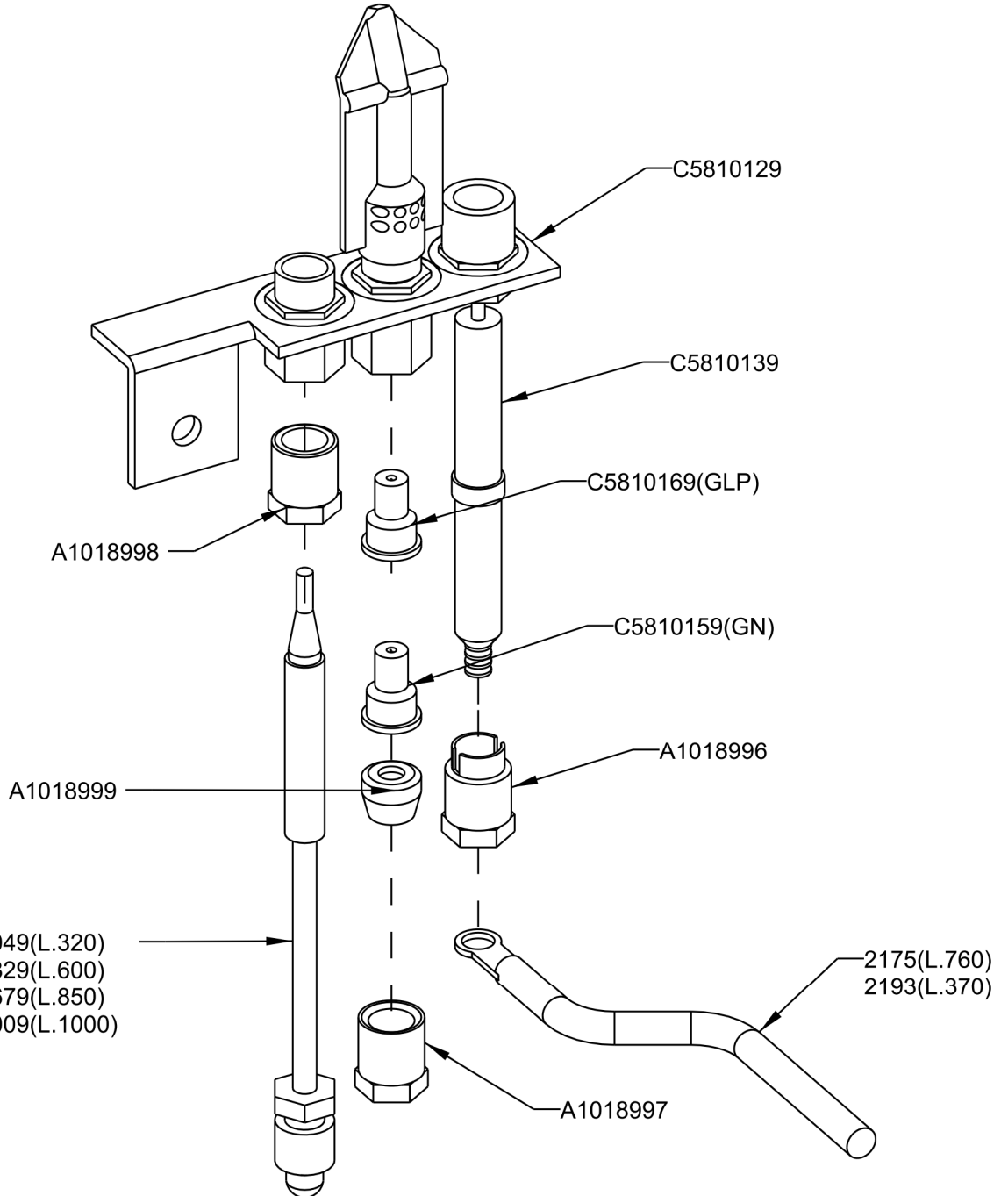

FUNDADA EN 1978
MASBAGA
FRANJAS COCINAS

EURAST

macfrin

TOLERANCIAS GENERALES: ±0.1 mm

macfrin
group
COOKING SYSTEMS,SL

FAMILIA: COCINAS 2008

MODELO: 3611

DATA:
09/09/08

DENOMINACION:
PILOTO POLIDORO COMPLETO

ESCALA:
1/1

MATERIAL:
FE

PROGRAMA:
C5810129M



926/MA/11/05



4785/ER/11/05

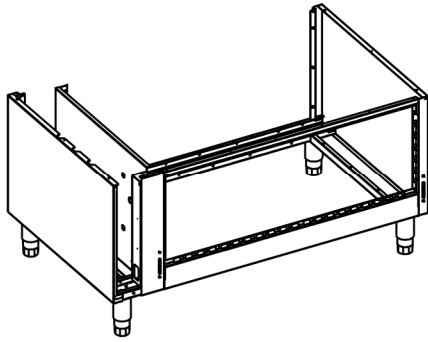

QT	COD	DESCRIPCION
2	61980	PORTARRULINO BISAGRA HORNO
2	350204	OMEGA COCINA 1200
1	490307	AISLANTE HORNO 2/1
1	490308	LATERAL DERECHO EXT.HORNO
1	490309	LATERAL DERECHO CANTONERA
1	490368	MONTANTE INTERMEDIO BISAGRA HORNO
2	490375	REFUERZO BISAGRA
1	499958	FRONTAL INFERIOR BOCA HORNO CHE
1	499965	FRONTAL SUPERIOR BOCA HORNO CHE
4	C6260511	PATA INOX 130-200 (S F)

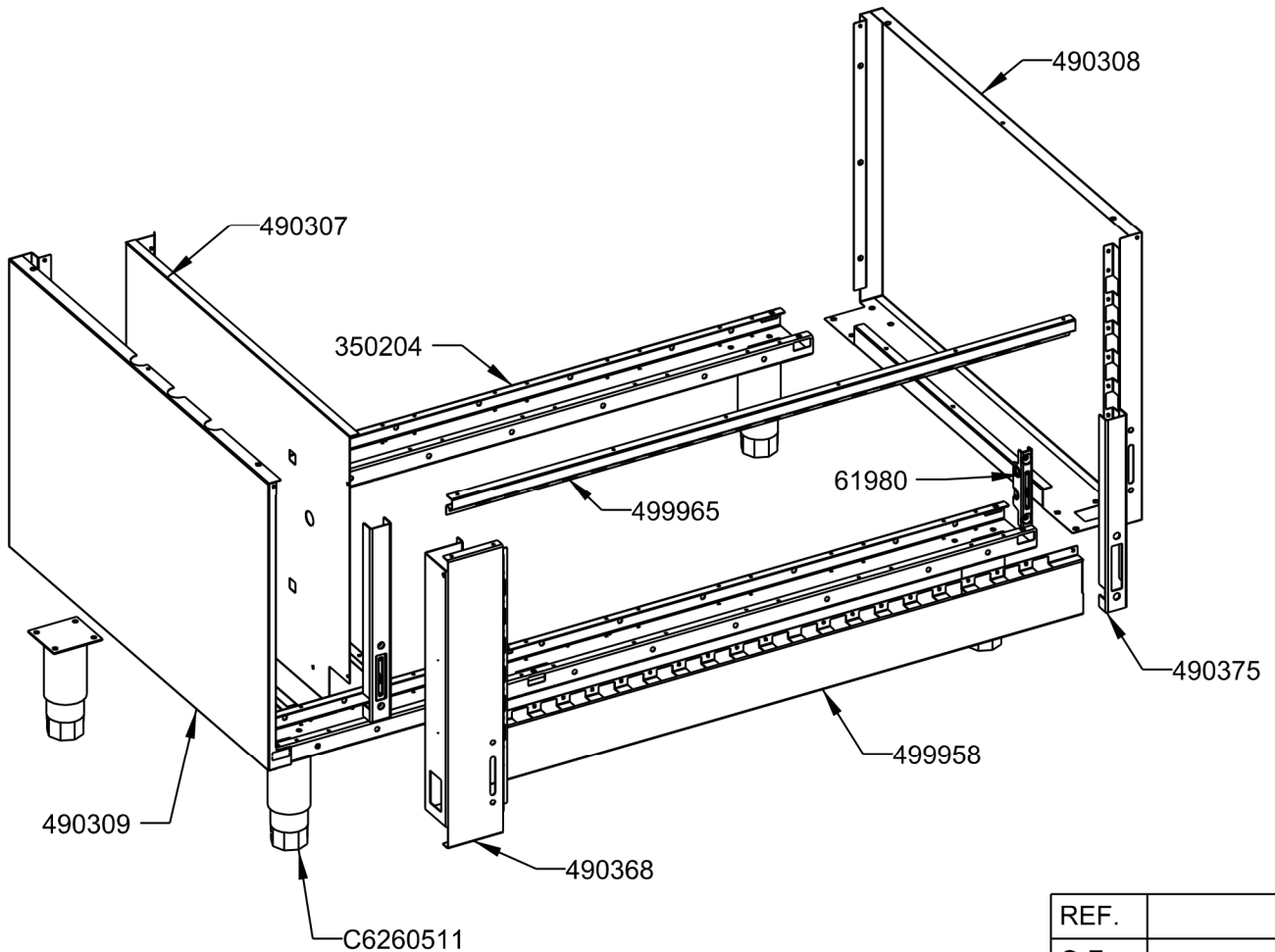

FUNDADA EN 1978
MAS BAGÁ
SEMPRE COCINANDO

EURAST

macfrin

TOLERANCIAS GENERALES: ±0.1 mm

macfrin
group
COOKING SYSTEMS,SL

FAMILIA: COCINAS 2008

MODELO: 4999

DENOMINACION:
CUBA EXTERIOR HORNO CHE

ESCALA:
1/10

MATERIAL:
INOX

REF.	
O.F.	
QT.	
DEST.	

DATA:
14/01/09

CODIGO:
4999-23-M



926/MA/11/05



4785/ER/11/05

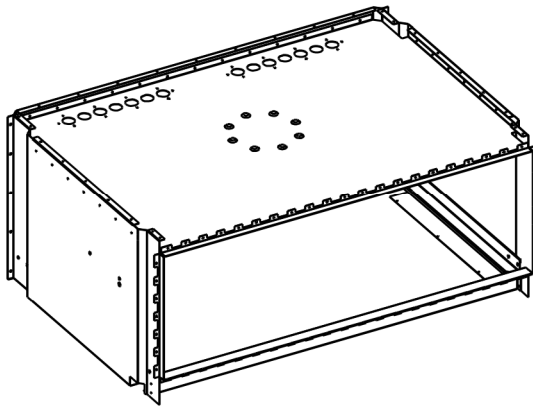

QT	COD	DESCRIPCION
1	490324	LATERAL IZQ.HORNO 2/1
1	490325	LATERAL DCHO. HORNO 750
2	490348	ANGULO APOYO PLANCHA HORNO
1	499921	TECHO HORNO CHE
1	499959	ZOCALO INTERIOR HORNO CHE
1	499964	TRASERO HORNO CHE

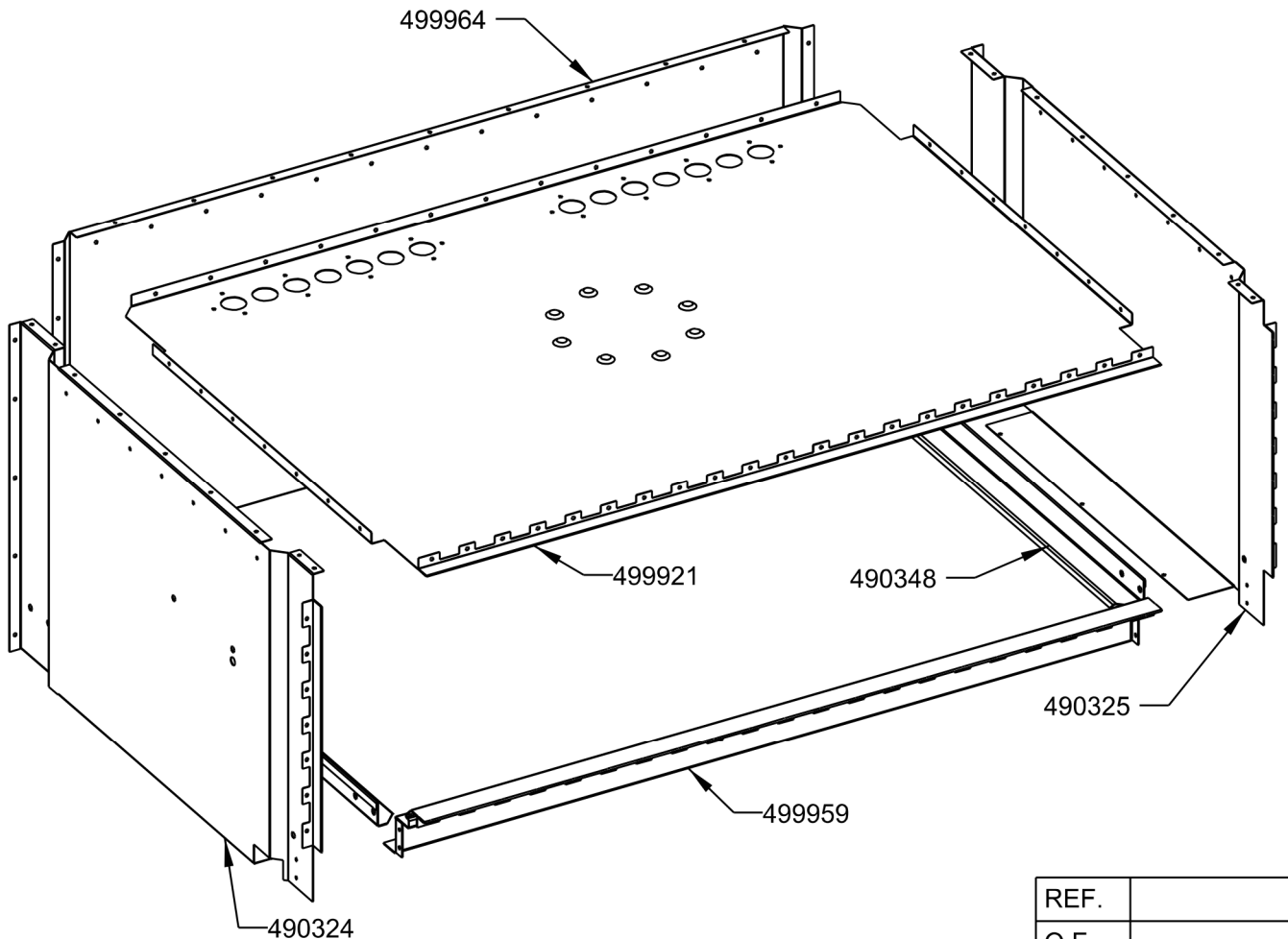

TOLERANCIAS GENERALES: ±0.1 mm

CONJUNTO REMACHADO
EXCEPTO 490348 ATORNILLADO CON RIVEKLE



FAMILIA: COCINAS 2008

MODELO: 4999

DENOMINACION:
CUBA INTERIOR HORNO CHE

ESCALA:
1/8

MATERIAL:
INOX

REF.	
O.F.	
QT.	
DEST.	

DATA:
14/01/09

CODIGO:
4999-24-M