



CB 1265

LIST OF THE EXPLODED VIEWS



SHELL ASSY

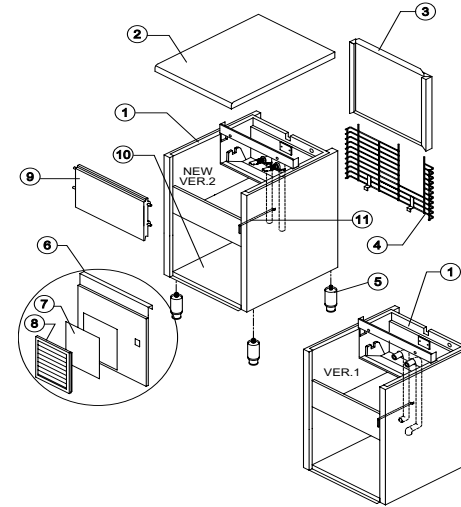

COOLING SYSTEM

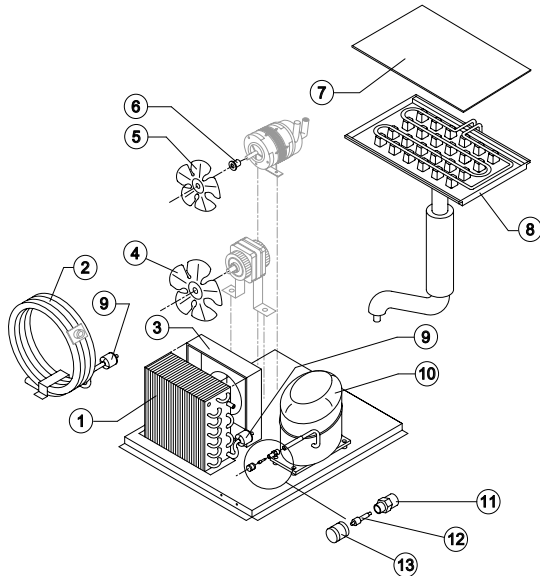

HYDRAULIC CIRCUIT

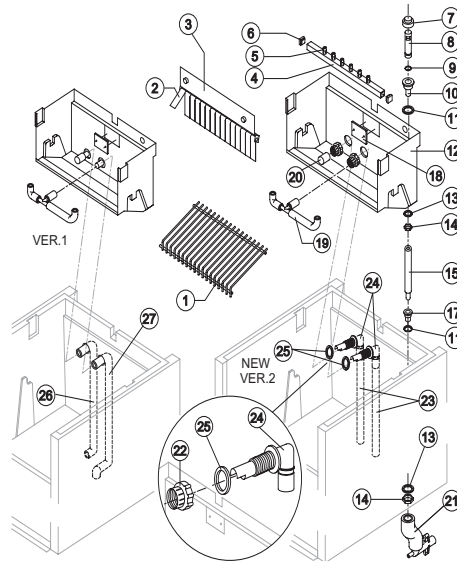

ELECTRIC PARTS

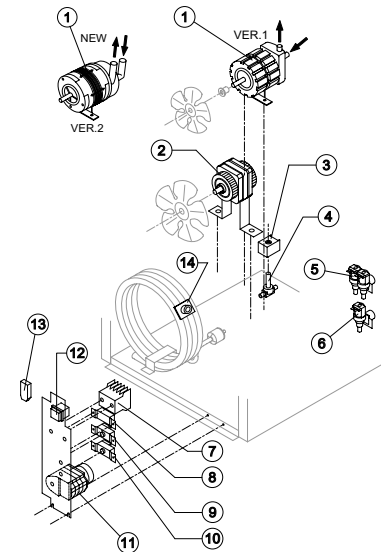

Rev. 3 - 2/7/2003

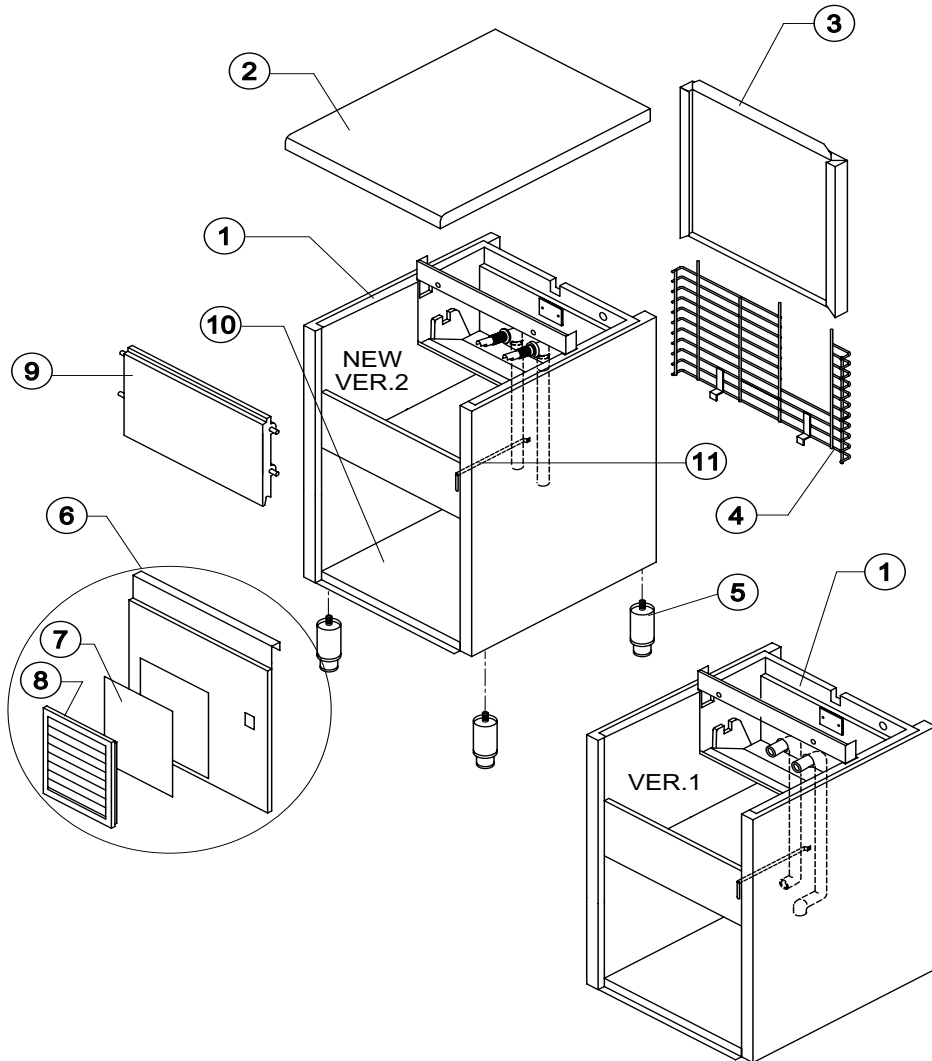

Rev. 3 - 2/7/2003

Ref.	Spare Description	Code
1	Foamed Cabinet Assy	See Table
2	Top Assembly	C22688
3	Back Panel Assembly	C21209
4	Back Grid	D12021
5	Stainless Steel Foot Adjustable	Current Version
5	ABS Foot	Till s/n. 142534
6	Front Grid Panel	C22564
7	Filtering Panel	18106
8	Frame with Grid & Filter	C10205
9	Door Assy	C10275
10	Base Plate	Current Version
10	Base Plate	Till s/n. 142534
11	Bulbe Thermostat Tube	20521

Ref. 1 - Foamed Cabinet Assy

Code	Condensation	Note
C11086A	Air	Version 2
C11086W	Water	Version 2
C11086/E		Version 1

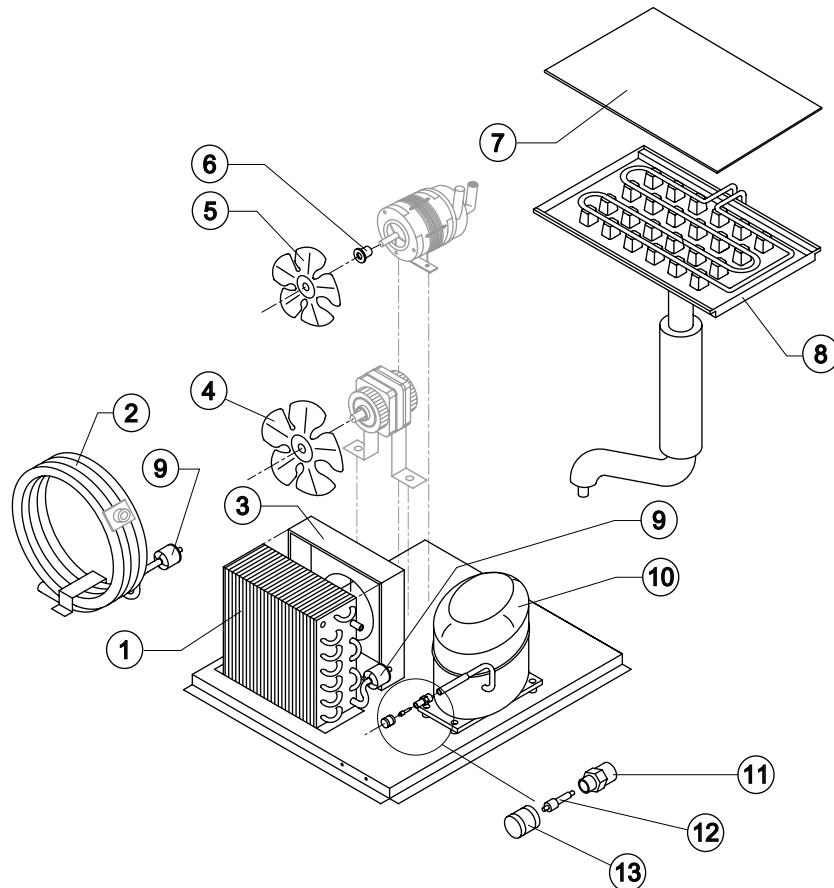

Common Parts

Ref.	Spare Description	Code
5	Suction Fan	10213
6	Hub for the Fan Fixing	10014
7	Evaporator Cover	10058
8	Evaporator	See Table
9	Solid Core Drier	14089
10	Compressor	See Table
11	Vacuum-Charge Valve Body	14007
12	Vacuum-Charge Valve Device	14005
13	Vacuum-Charge Valve Plug	14006

Parts for Air-Cooled Version Only

Ref.	Spare Description	Code
1	Air Condenser	20264
3	Air Condenser Conveyor	10163
4	Suction Fan	20031

Parts for Water-Cooled Version Only

Ref.	Spare Description	Code
2	Water Condenser	14034
4	Suction Fan	10213

Ref. 8 - Evaporator

Kind of Cube	Code
18 g. (Standard)	D10214
33 g. (Big)	D10092
13 g. (Small)	D10126

Ref. 10 - Compressor

Tension	Code
220/240V 50 Hz	23440
220/230V 60 Hz	23465
110/115V 60 Hz	23554



CB 1265

HYDRAULIC CIRCUIT

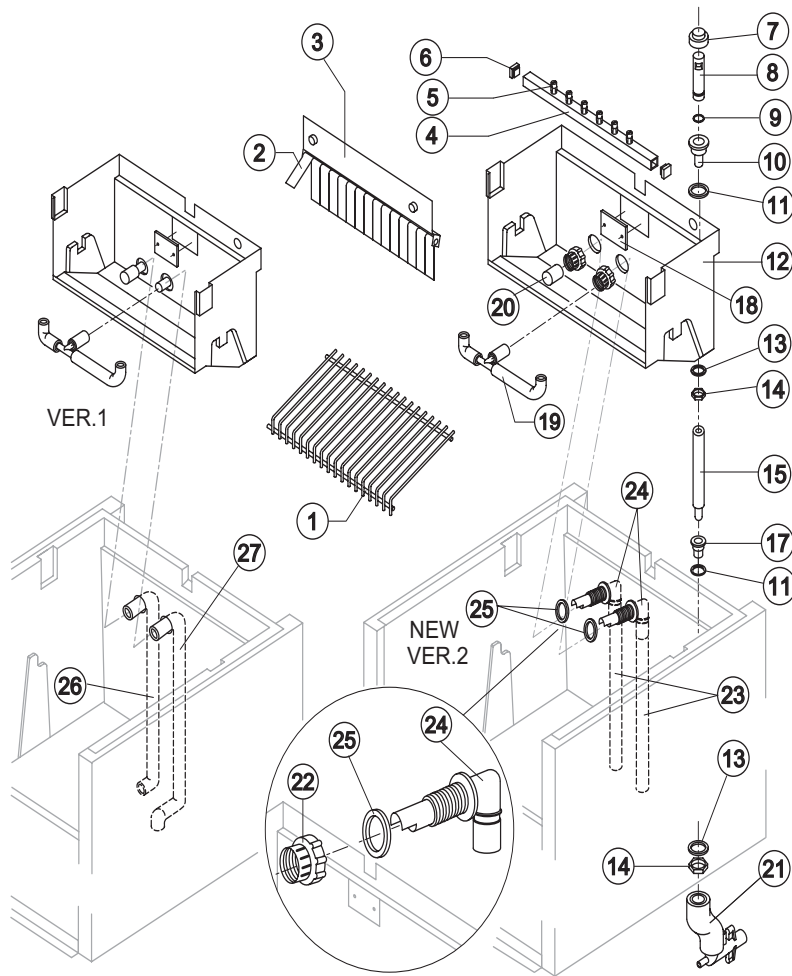

Common Parts

Ref.	Spare Description	Code
1	Ice Cubes Slide	See Table
2	Flag	10005
3	Flags Support Assy	C22134
4	Sprayers Bar Assembly	See Table
5	Sprayer	D20002
6	Sprayers Bar Plug	10012
7	Overflow Cap	10305
8	Overflow Pipe	10133
9	OR Gasket for Overflow Pipe	20233
10	Overflow Pipe Nipple	10241
11	Silicone Gasket	13006
12	Inner Basin	10055
13	Semirigid Polyethylene Gasket	13007
14	Bin Discharge Nut	10096
15	Overflow Pipe Assembly	C13110
17	Plastic Nipple Water Outlet	10007
18	Slide Keep Plate	10009
19	Sprayers Bar Pipe Connection Assy	C13036
20	Pump Suction Filter	20005
22	Fitting Locking Ring	Version 2 10405
23	Pump Suction/Delivery Pipe	Version 2 13142
24	Fitting of the Pump Suction/Delivery Pipes	Version 2 10404
25	Gasket for Suction Line/Pump delivery	Version 2 13143
26	Pump Suction Pipe	Version 1 13096
27	Pump Delivery Pipe	Version 1 13095

Ref. 1 - Ice Cubes Slide

Kind of Cube	Code
18 g. (Standard)	D12022
33 g. (Big)	D12033
13 g. (Small)	D12040

Ref. 6 - Sprayers Bar Ass.

Kind of Cube	Code
18 g. (Standard)	C20144
33 g. (Big)	C20157
13 g. (Small)	C20200

Parts for Air-Cooled Version Only

Ref.	Spare Description	Code
21	Discharges Manifold	C10006

Parts for Water-Cooled Version Only

Ref.	Spare Description	Code
21	Discharges Manifold	C26452

Rev. 3 - 2/7/2003



CB 1265

ELECTRIC PARTS

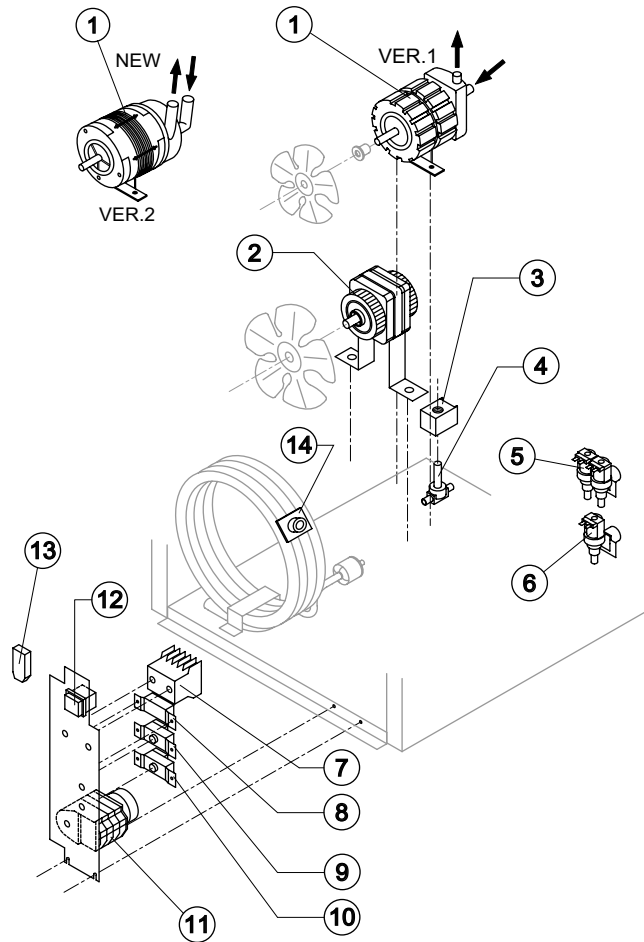

Common Parts

Ref.	Spare Description	Code
1	Pump	See Table -
2	Fan Motor	See Table -
3	Hot Gas Coil	See Table -
4	Hot Gas Valve Body	20409
7	Contactor	Only 110V 60 Hz 23595
8	Condenser Pressure Switch	23175
9	Bin Thermostat	23005
10	Evaporator Thermostat	23591
11	Timer	See Table -
12	Green Light Switch	23327

Parts for Air-Cooled Version Only

Ref.	Spare Description	Code
6	Inlet Watervale 1 Way	See Table -
13	Anti Radio Interference Filter	Only 220V 50 Hz 23459

Parts for Water-Cooled Version Only

Ref.	Spare Description	Code
5	Inlet Watervale 2 Ways	See Table -
13	Anti Radio Interference Filter	Only 220V 50 Hz 23457
14	Safety Thermostat	C23114

Ref. 1 - Pump

Tension	Version 1	Version 2
220/240V 50 Hz	23068	23462
220/230V 60 Hz	23068	23462
110/115V 60 Hz	23264	23663

Ref. 2 - Fan Motor

Tension	Air	Water
220/240V 50 Hz	23067	23029
220/230V 60 Hz	23681	23029
110/115V 60 Hz	23621	23683

Ref. 3 - Hot Gas Coil

Tension	Code
220/240V 50 Hz	23091
220/230V 60 Hz	23091
110/115V 60 Hz	23256

Ref. 5 - Inlet Watervale 2 Ways

Tension	Code
220/240V 50 Hz	23157
220/230V 60 Hz	23157
110/115V 60 Hz	23282

Ref. 6 - Inlet Watervale 1 Way

Tension	Code
220/240V 50 Hz	23108
220/230V 60 Hz	23108
110/115V 60 Hz	23281

Ref. 11 - Timer

Tension	18 g Cube	33 g Cube	13 g Cube
220/240V 50 Hz	23222	23248	23247
220/230V 60 Hz	23248	23396	23247
110/115V 60 Hz	23259	23397	23258

Rev. 3 - 2/7/2003