

# (ET)

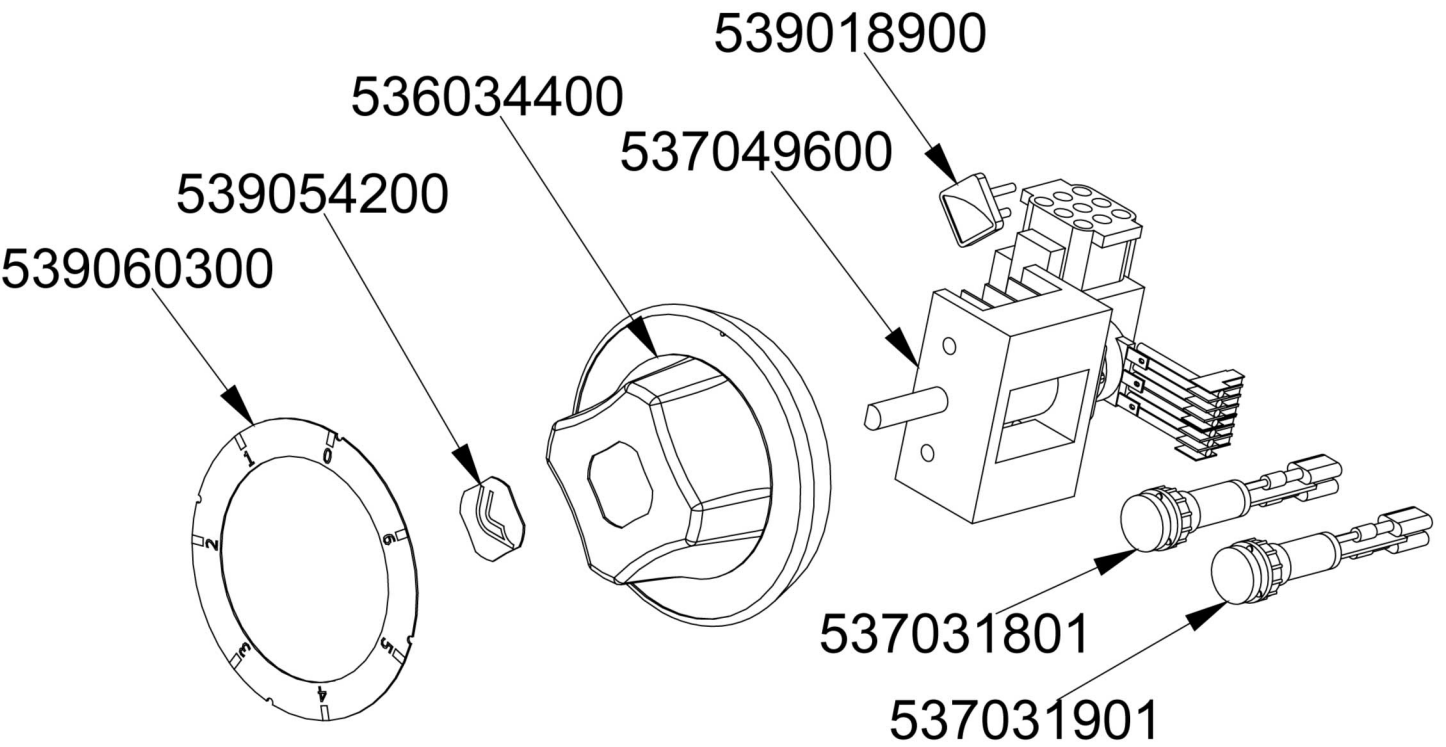

# (ETD)

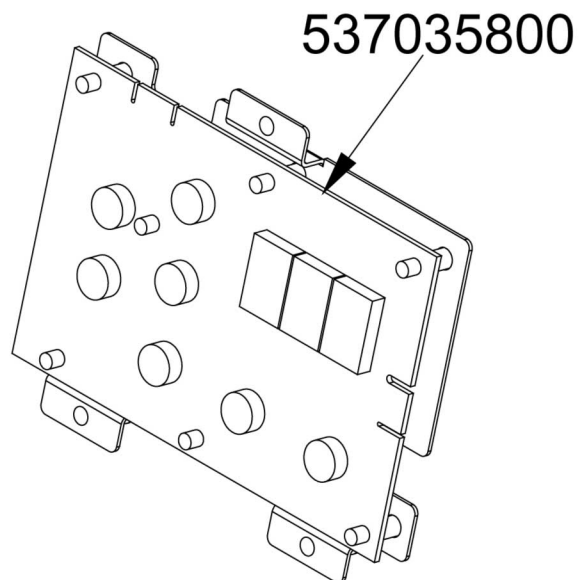

Page	Pos	Code	Description
001		532004100	FLUE GRID L=370 90LINE (RAF
001		541118402	UPPER PLATE S90 PCI-94E VC
001		537048700	PLATE WITH INDUCTORS S90
001		537045800	GENERATOR PCI-94 5KW 400V3 (C
001		544446900	LHD SIDE FOR 90T APPLIANCES
001		537027400	TERMINAL BLOCK THREEPHASE 40A
001		541196700	CONTROL PANEL S607090 PCIW-74ETD V
001		544446800	
001		533010500	LEG M10*25 D.40
001		531034800	NET FILTER FOR KSK
002		539018900	INDEX FOR KNOB W/RED SIGN
002		537049600	COMPLETE CONTROL FOR INDUCTORS
002		536034400	KNOB \$77 4P. \$06*4,6 C/M
002		539054200	STAMP Ø20,5 CR. "L" LOTUS R.
002		539060300	RED ADESIVE DISK FOR PCC/PCI-E
002		537031801	GREEN WARNING LIGHT 12V E FASTON
002		537031901	RED WARNING LIGHT PCI 12V E FASTON
002		537035800	TOUCH ELECTRONIC BOARD FOR PCI