

560079101M00P00

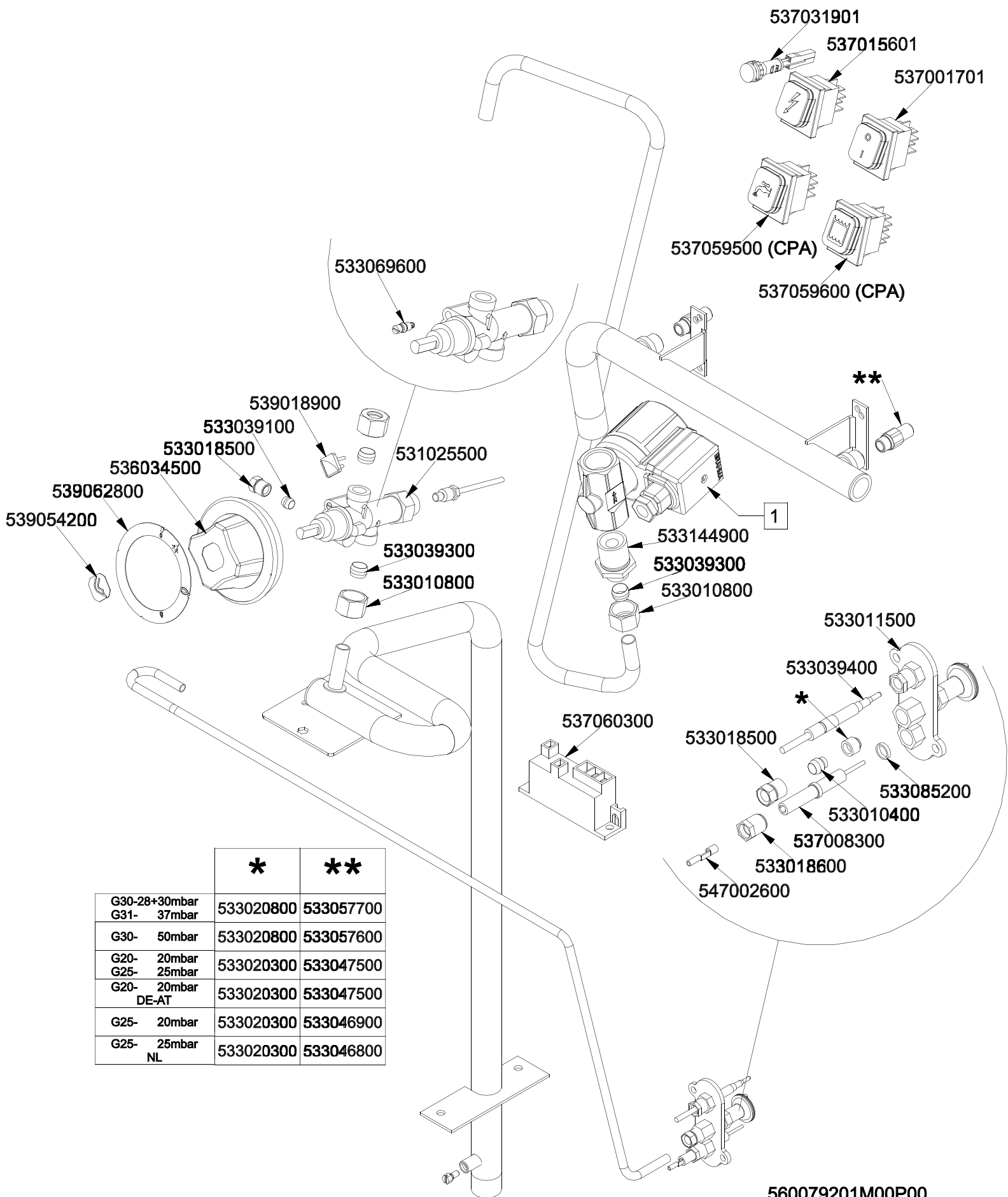

	*	**
G30-28+30mbar G31- 37mbar	533020800	533057700
G30- 50mbar	533020800	533057600
G20- 20mbar G25- 25mbar	533020300	533047500
G20- 20mbar DE-AT	533020300	533047500
G25- 20mbar	533020300	533046900
G25- 25mbar NL	533020300	533046800

560079201M00P00

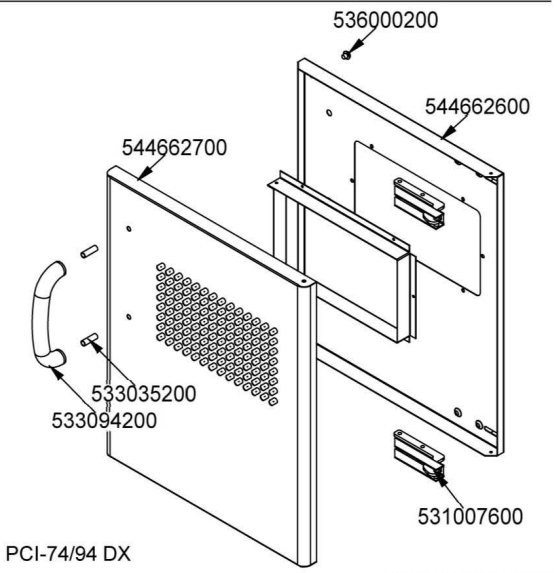
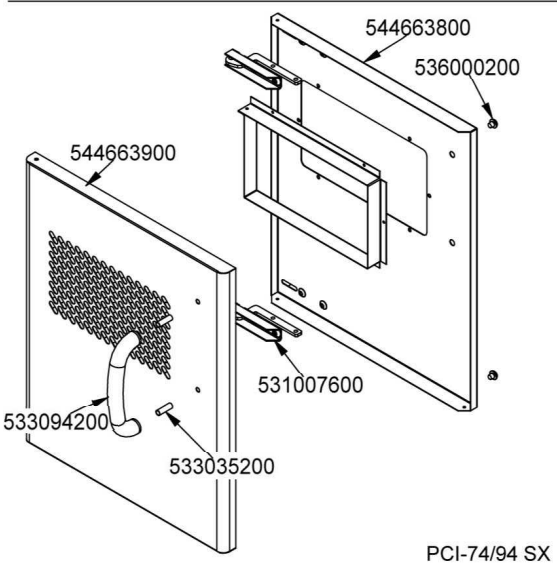
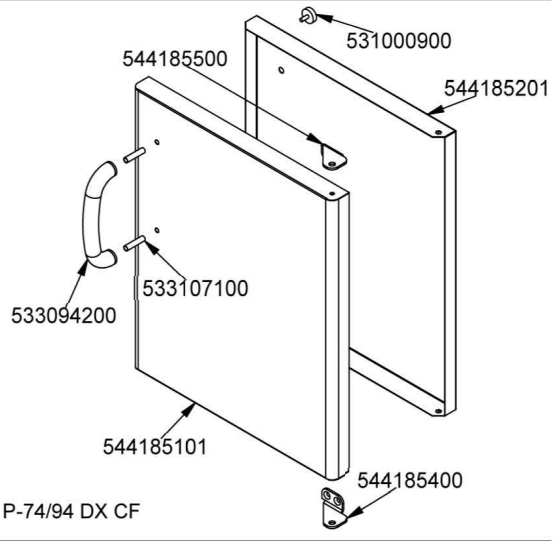
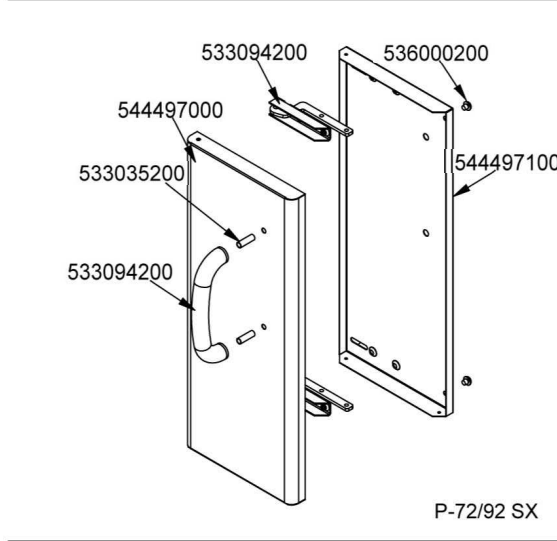
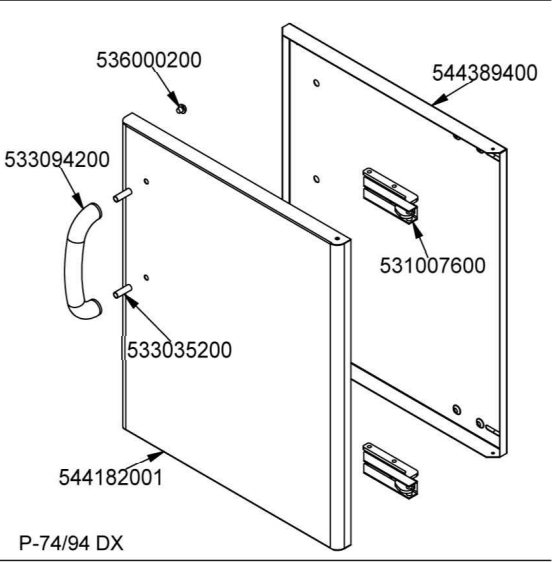
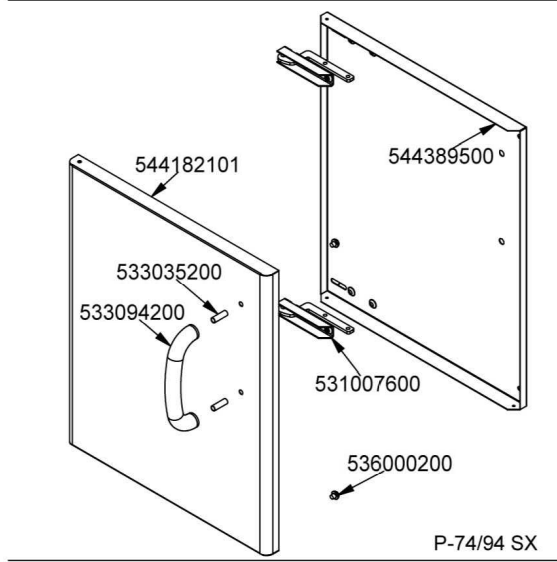
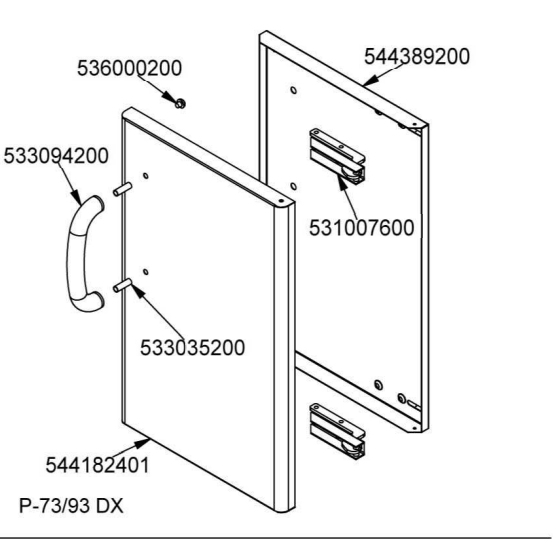
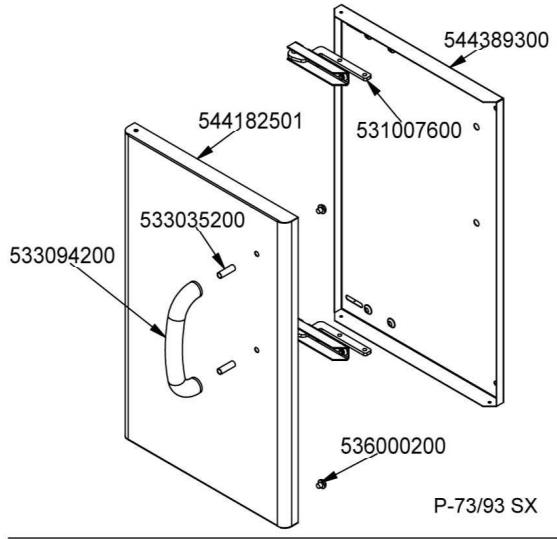

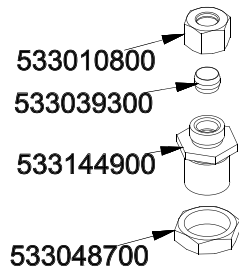
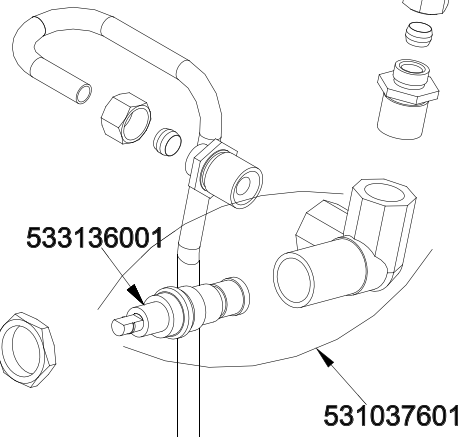
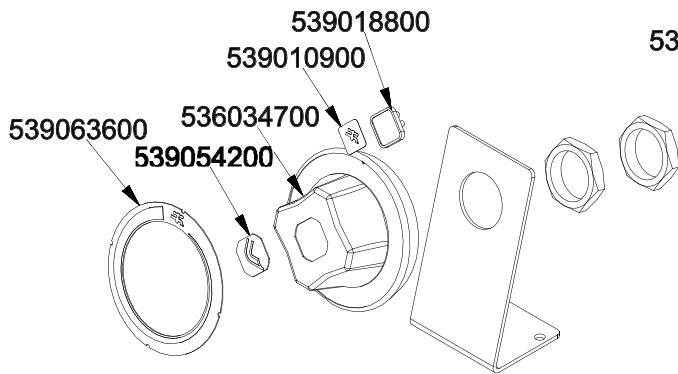
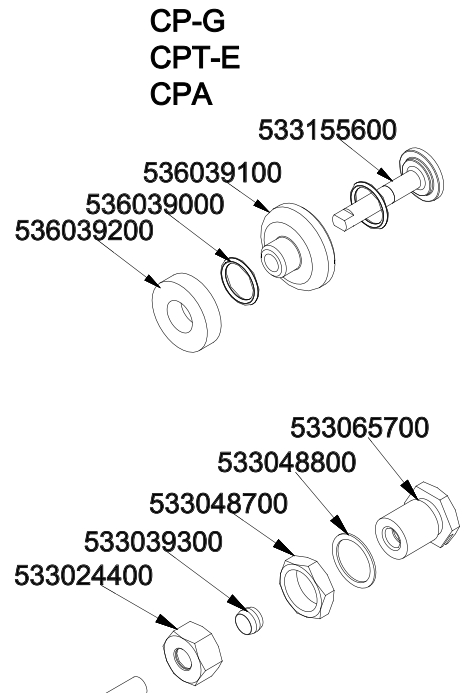
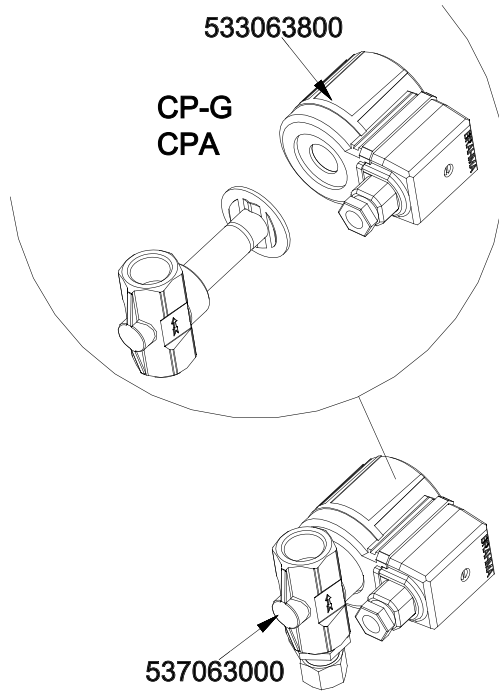
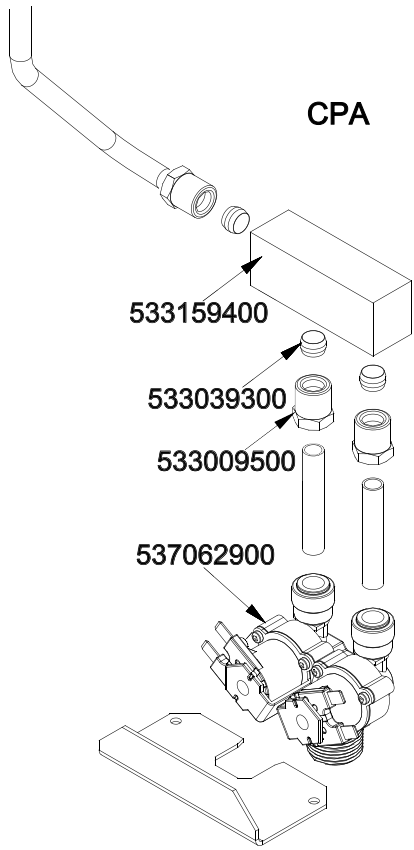

Page	Pos	Code	Description
001		531037701	BASKET SUPPORT GRID CP S.90
001		546005400	RUBBER TUBE §25INT.*§33EXT.*L=470
001		541199902	ASS.PIANO S60T CP -66G
001		531018600	BALL VALVE 1"G M-F CPM-62G
001		533157400	FERMO PROLUNGA RUBINETTO 1"G Ø14
001		533157300	PROLUNGA RUB.1"G S90
001		533039900	PIPE HOLDER 1" G M D.24
001		533038200	1" G M-F ELBOW FITTING
001		541008100	DRAIN FILTER TANK CP 700LINE
001		531042800	SEMISPHERE FILTER
001		544508700	FIANCO APP.S60M SX
001		533149800	PROLUNGA 1 G M/F L 55
001		533040000	1"G F-F-F "T" FITTING
001		533149500	PROLUNGA 1 G M/M FE ZINC L100
001		541142700	BURNER SUPPORT FT-76G CP-76G
001		531056300	BURNER TUB.07 KW CP-76G S70
001		541140702	ASS.CRUSC.S607090 CP-76G
001		537062800	CENTR.SENS.ACQUA E RAB.CP 230V
001		544508600	FIANCO APP.S60M DX
001		537003800	TERMINAL BLOCK 3POLES 16A
001		531048400	INOX LEG Ø1"3/4 100-165 M10
002		537031901	RED WARNING LIGHT PCI 12V E FASTON
002		537015601	P.D.INTERR.IST.NERO FULMINE
002		537001701	P.D.INTERR.LUM.VERDE 0 1
002		537059500	
002		533069600	BY PASS COCK §130 20S-21S
002		537059600	
002		539018900	INDEX FOR KNOB W/RED SIGN
002		533039100	BICONE §6
002		531025500	GAS COCK 21S P.V.BY-PASS Ø130
002		533018500	FITTING FOR BICONE D.6 M10*1
002		536034500	KNOB §77 4P. §08*6,5
002		539062800	RED STICKING DISK 72
002		539054200	STAMP Ø20,5 CR."L" LOTUS R.
002		533144900	MALE FITTING WATER INLET M16X1,5
002		533039300	BICONE §10
002		533010800	TUBE NUT D.10 M16*1,5
002		533011500	PILOT BURNER 2 FLAMES 220
002		533039400	THERMOCOUPLE M9*1*850
002		537060300	IGNITION CONTROL BOX 2F. V30
002		533085200	SPACER FOR PILOT PLUG
002		533010400	BICONE D.6
002		537008300	ROUND PLUG §2,4- LONG ELECTRODE
002		533018600	PLUG FITTING
002		547002600	HIGH-VOLTAGE CABLE L=500
002		533020800	NOZZLE 0160-FLUSS. (25
002		533020300	NOZZLE 0160 (NATURAL GAS) 1-2 (41
002		533057700	NOZZLE §130A CH12*30 F-BRF74
002		533054600	
002		533047500	NOZZLE §205 CH12*30 ML-BM-8G
002		533046900	NOZZLE §225 CH12*30 G25 F1 25MBAR

Page	Pos	Code	Description
002		533046800	NOZZLE §210 CH12*30 M-F1
003		544389300	CONTROP.73 SX APP. LT
003		531007600	DOOR HINGE
003		544182501	LEFT DOOR 73
003		533094200	S/S HANDLE FOR 70/90 SERIES
003		533035200	HANDLE SPACER
003		536000200	D.12 H.4 BUMPER
003		544389200	CONTROP.73 DX APP. LT
003		544182401	RIGHT DOOR 73
003		544182101	LEFT DOOR 74
003		544389500	INNER-DOOR OF LHD 74
003		544389400	CONTROP.74 DX APP. LT
003		544182001	RIGHT DOOR 74
003		544497000	PORTA 72 SX
003		544497100	CONTROP.72 SX APP. LT
003		544185101	RIGHT DOOR 74 CF
003		533107100	HANDLE SPACER OF CF-70
003		544185500	UPPER DOOR HINGE FOR COMPARTME CF70
003		531000900	MAGNET §22 KG.3 WITH DISK
003		544185201	INNER DOOR * 74DX
003		544185400	LOWER DOOR HINGE FOR COMPARTME CF70
003		544663900	LHD 74 DOOR FOR PCI
003		544663800	74 LHD OVEN INNER DOOR FOUR PCI
003		544662700	DOOR 74 DX PCI
003		544662600	CONTROP.74 DX APP. LT PCI
004		533155600	PERNO PER SENSORE ACQUA
004		536039100	GUIDA PER SENSORE ACQUA
004		536039000	GUARNIZ.O-RING 12,42X1,78 SILIC.
004		536039200	DISTANZIALE PER SENSORE ACQUA
004		533159400	RACC.UN.2 U.ELETTROV.ACQUA CP
004		533039300	BICONE §10
004		533009500	NIPPLE FOR BICONE 10S
004		537062900	ELETTROV.A.3/4GM-2Ø10JG 230V RPV
004		533065700	FITTING FOR WATER INPUT 1/2G
004		533048800	GASKET §30*§21*2 FIBRE
004		533048700	NUT 1/2G ZN
004		533024400	HEXAGONAL NUT 1/2G TUBE D.10
004		537063000	ELETTROV.G.1/2GF-1/2GF 230V
004		539018800	BLANK INDEX FOR KNOB
004		539010900	ADHESIVE LABEL FOR DRAIN COCK
004		536034700	KNOB §77 4P. §08*6,5 F§30
004		539063600	ADHESIVE DISK 72 FOR DRAIN COCK
004		539054200	STAMP Ø20,5 CR."L" LOTUS R.
004		533136001	SCREW TAP WATER LOAD FOR CP S70/90
004		531037601	TAP FOR WATER 90°DX CP
004		533010800	TUBE NUT D.10 M16*1,5
004		533144900	MALE FITTING WATER INLET M16X1,5