

1 2 3 4 5 6 7 8

A

B

C

D

E

F

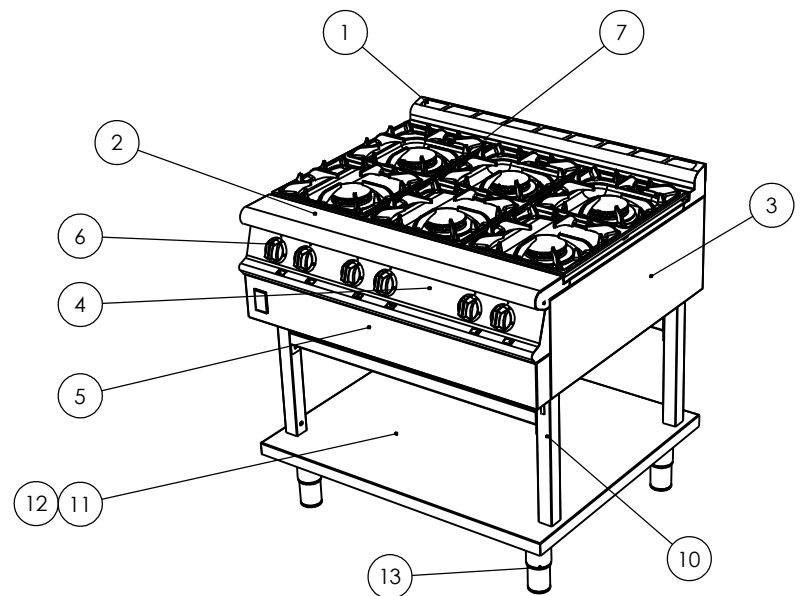
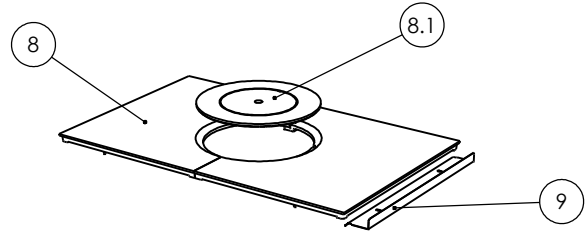

ITEM	DESCRIPTION	G3121	G3127	G3124
		SPARES No	SPARES No	SPARES No
1	REAR HOB RAIL	535290017	535290017	535330004
2	FRONT HOB RAIL	535290018	535290018	535330005
3	OUTER SIDE PANEL	535400190	535400190	535400190
4	CONTROL PANEL	535340000	535350000	535360001
5	CONTROL PANEL LOWER FACIA	535340001	535340001	535360002
6	HOB CONTROL KNOB	535290025	535310010	535290025
7	PAN SUPPORT	535290027	N/A	535290027
8	SOLID TOP CASTING COMPLETE	N/A	535400170	N/A
8.1	SOLID TOP CENTRE & RING SET	N/A	535400160	N/A
9	HOB SIDE DRIP SHED	N/A	535410018	N/A
10	LEG STAND LEG ASSEMBLY	535400202	535400202	535460002
11	BOTTOM SHELF	535400203	535400203	535460003
12	BOTTOM FRAME (NOT SHOWN)	535400204	535400204	535460004
13	ADJUSTABLE FOOT	535290028	535290028	535290028
14	REAR FIXED CASTOR (NOT SHOWN)	534103055	534103055	534103055
15	FRONT SWIVEL CASTOR (NOT SHOWN)	530964350	530964350	530964350

A

B

C

D

E

F

**CLEARED FOR PRODUCTION**

ISSUE	MOD No	ALTERATION	DRAWN BY	DATE
A	6422	PRODUCTION ISSUE	IAIN JAMES	09/08/11

IF IN DOUBT ASK  
DO NOT SCALE  
FIRST ANGLE PROJECTION

UNLESS OTHERWISE SPECIFIED:  
DIMENSIONS ARE IN MILLIMETERS  
TOLERANCES:  
LINEAR: ±0.5mm  
ANGULAR: ±0.5 DEG

DEBUR AND  
BREAK SHARP EDGES

WEIGHT: g



DRAWN: <b>IAIN JAMES</b>	PRODUCT
DATE: <b>31/05/11</b>	TITLE
SCALE: <b>1:10</b>	
MATL: -	DRAWING NUMBER
THICKNESS:	FINISH:
BIN No:	PART No:

<b>G3121/27/24</b>	
<b>SPARES - FITMENTS</b>	
<b>AA48643</b>	A

© NO REPRODUCTION OR PUBLICATION OF THIS DRAWING MAY BE MADE AND NO ARTICLE MAY BE MANUFACTURED OR ASSEMBLED IN ACCORDANCE WITH THIS DRAWING WITHOUT PRIOR WRITTEN CONSENT. THIS PROHIBITION IS A TERM OF ANY CONTRACT RELATING TO THIS DRAWING. RIGHTS RESERVED UNDER THE COPYRIGHT ACT 1956 AS AMENDED BY THE DESIGN COPYRIGHT ACT 1968

**Falcon Foodservice Equipment Wallace View Hillfoots Road Stirling Scotland**

SHEET 1 OF 1

A3