

CPM-62G

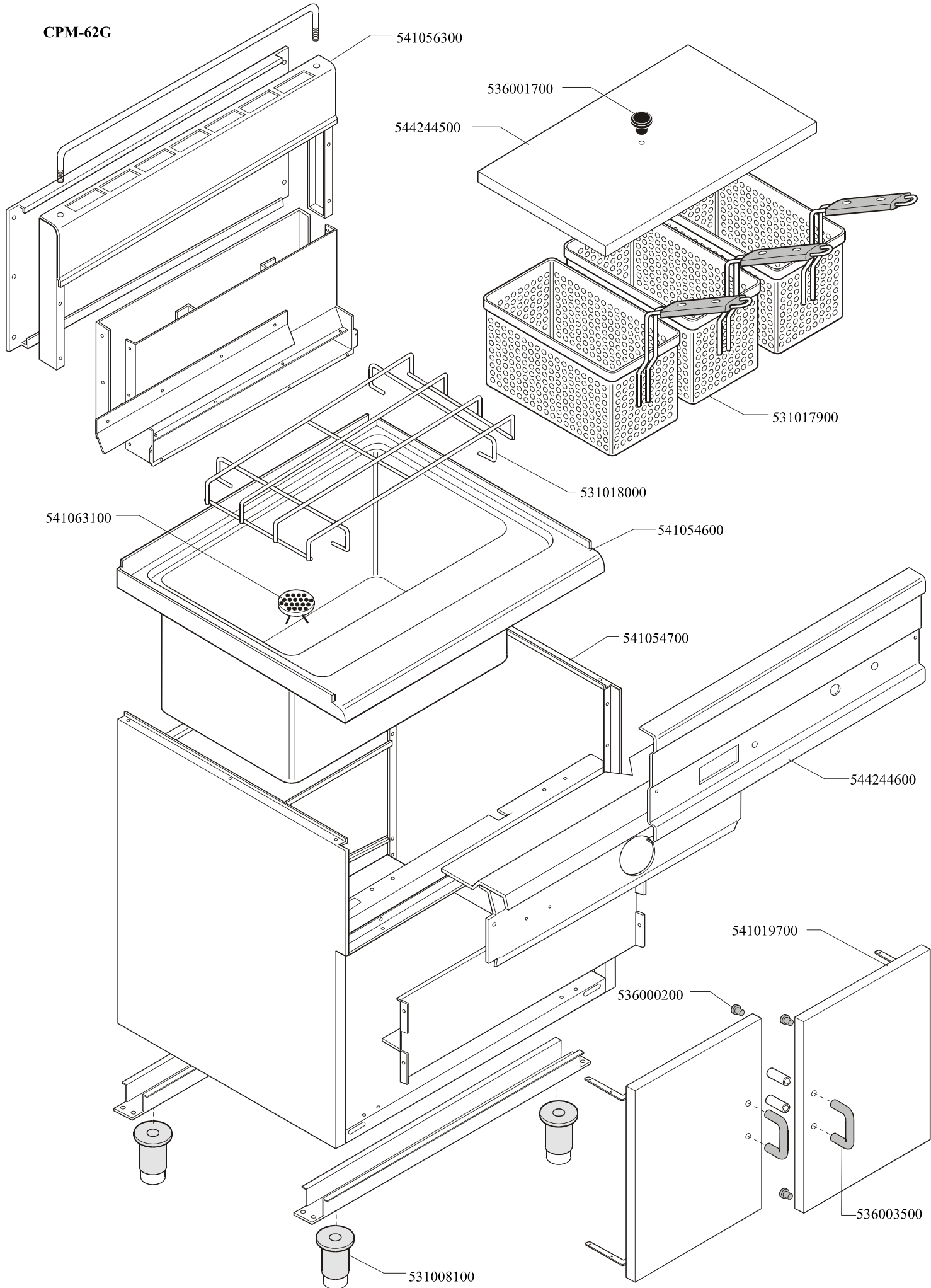

	*	**
G30- 28+30mbar G31- 37mbar	533020200	533046400
G30- 50mbar	533020200	533046300
G20- 20mbar G25- 25mbar	533020400	533032001
G25- 20mbar	533020400	533046500
G25- 25mbar NL	533020400	533032801

CPM-62G

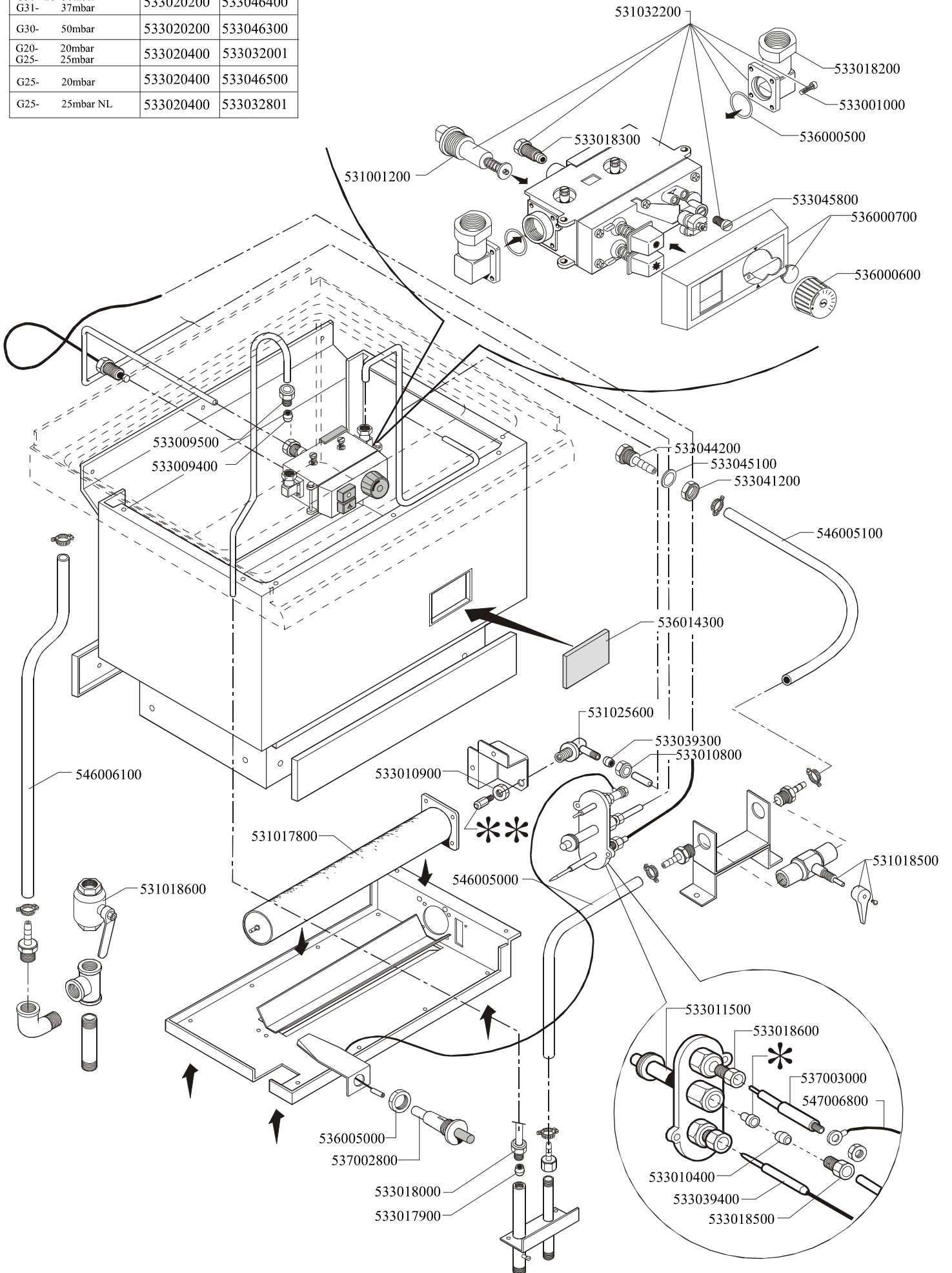

Page	Pos	Code	Description
001		541056300	SPACER CPM-62G
001		536001700	GRIP D.25*19*M6
001		544244500	TANK LID CPM-62/6G
001		531017900	PASTACOOKER BASKET 1/3 160X290X200H
001		541063100	TANK DRAIN FILTER BS-4EM/CPM
001		531018000	BASKET SUPPORT GRID CPM-62G
001		541054600	UPPER PLATE CPM-62G
001		541054700	FRAME CPM-62G
001		544244600	CONTROL PANEL CPM-62G
001		541019700	DOOR 61
001		536003500	RED HANDLE 60/SK
001		536000200	D.12 H.4 BUMPER
001		531008100	ADJUSTABLE LEG H9 CHROME
002		531032200	MINISIT VALVE CPM-62G
002		531001200	MAGNET AC/2-MINISIT
002		533018300	FITTING WITH BICONE 6 M10*1
002		533018200	ELBOW OR GJ 3/8
002		533001000	SCREW TCB C/CC M4X16
002		536000500	O-RING FOR MINISIT FITTING
002		533045800	SCREW §10 FOR MINISIT VALVE
002		536000700	PLASTIC COVER FOR MINISIT + SCREW
002		536000600	BLACK LHD KNOB OP. FOR MINISIT
002		533009500	NIPPLE FOR BICONE 10S
002		533009400	BICONE 10S
002		533044200	H.20 INPUT FITTING
002		533045100	GASKET §E24*§I18*SP.1,5
002		533041200	HEXAGONAL NUT 3/8" G
002		546005100	RUBBER TUBE §10INT.*§18EXT.*L=300
002		536014300	INSPECTION HOLE GLASS PANE CPM-62G
002		546006100	RUBBER TUBE §25INT.*§33EXT.*L=560
002		531018600	BALL VALVE 1"G M-F CPM-62G
002		531018500	BALL VALVE 1/2" F-F CPM-62G
002		531025600	ELBOW 90° NOZZLE-HOLDER §10 PIPE
002		533039300	BICONE §10
002		533010800	TUBE NUT D.10 M16*1,5
002		546005000	RUBBER TUBE §I10E18*L=900 100°C
002		533010900	NUT M14*1 H.4
002		531017800	BURNER CPM-62G POLID.103.1515.0
002		533011500	PILOT BURNER 2 FLAMES 220
002		533018600	PLUG FITTING
002		537003000	PLUG M4 - LONG ELECTRODE
002		547006800	HIGH-VOLTAGE CABLE OCC.§4-TUBE§2 L7
002		533010400	BICONE D.6
002		533039400	THERMOCOUPLE M9*1*850
002		533018500	FITTING FOR BICONE D.6 M10*1
002		536005000	NUT M18 FOR PIEZOELECTRIC IGNITION
002		537002800	PIEZOELECTRIC IGNITION M18
002		533018000	ELBOW FOR BICONE D.12 3/8 RS L20
002		533017900	BICONE D.12
002		533020200	PILOT JETS 0160 FOR LPG §30
002		533046400	NOZZLE §185 CH12*30 G-CPM

<b>Page</b>	<b>Pos</b>	<b>Code</b>	<b>Description</b>
002		533046300	NOZZLE \$160 CH12*30 F-CPM
002		533020400	NOZZLE 0160 (NATURAL GAS) 51
002		533032001	NOZZLE \$270 CH12*30 MH-CPM
002		533046500	NOZZLE \$290 CH12*30 L-CPM
002		533032801	NOZZLE \$280 CH12*30 M-CPM