



Applus®
LGAI
Organismo Notificado
0370

AENOR
Organismo Notificado
0099



TOLERANCIAS GENERALES: ± 0.5 mm

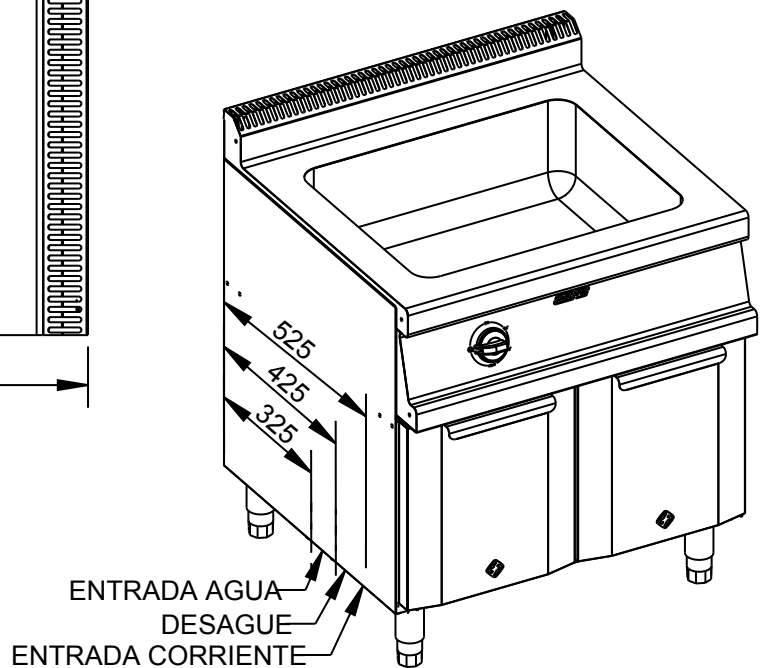
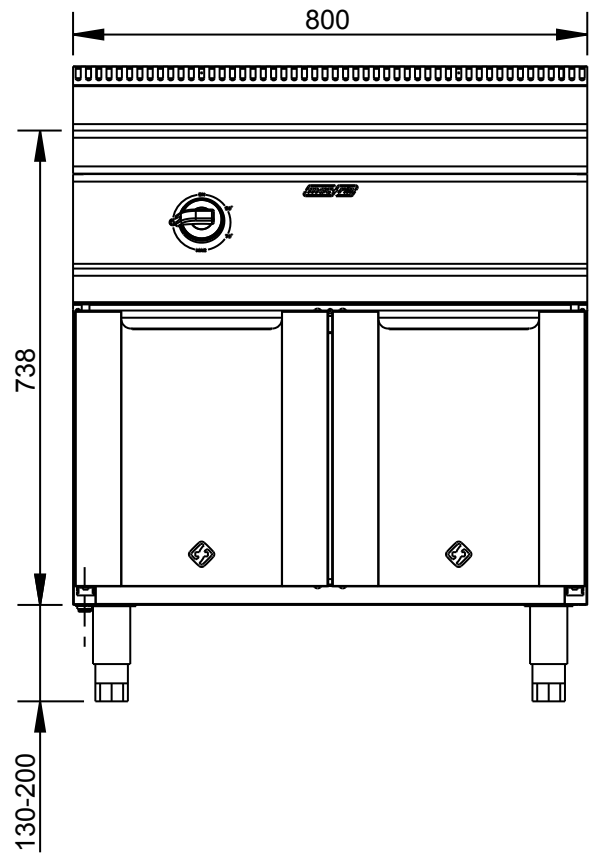
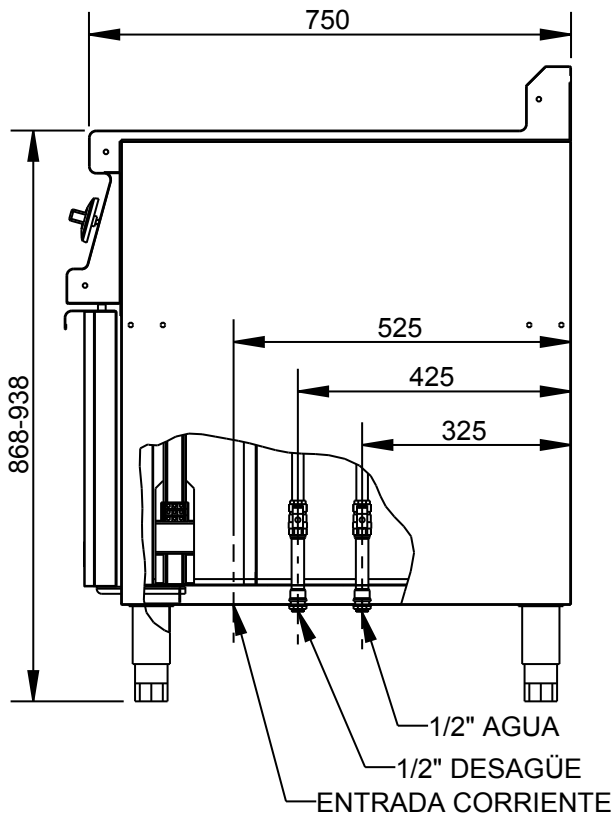

POTENCIA: 2.000W 220V



FAMILIA: COCINAS 2008

FECHA: 14/02/11

MODELO: 3704 - RMBE - BM87E

PESO(Kg): 42.292

DENOMINACION:
B°M^a 800x750

ESCALA:
1/10

MATERIAL:
INOX

CODIGO:
3704



Applus®
LGA1
Organismo
Notificado
0370

AENOR
Organismo
Notificado
0099

FUNDADA EN 1878
MASBAGA
GRANDES COCINAS

EURAST

mag-fin

TOLERANCIAS GENERALES: ± 0.5 mm

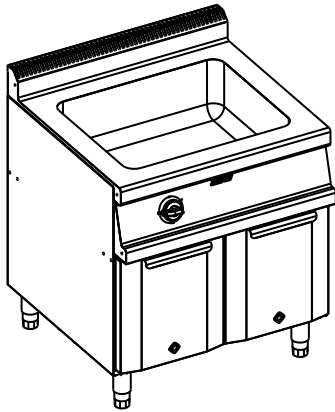

QT	COD	DESCRIPCION
3	3054	MACHON 1/2"
2	3167	VALVULA DE BOLA DE 2 VIAS 1/2"
2	3242	TUERCA LATON 1/2"
1	93649	DESAGUE COMPLETO 3/4"
1	93650	ENTRADA AGUA 1/2"
1	330213	TRASERO 800
1	332648	GUIA CONTACTORES 400
2	350104	OMEGA COCINA 800
2	350503	BISAGRA
1	350508	LATERAL DERECHO 750
1	350509	LATERAL IZQUIERDO 750
1	350563	BASE 800 X 750
1	350565	FRONTAL INFERIOR 800
1	490276	SOPORTE GUIA 332748-REG.MOTOR
1	936501	JUNTA PLANA 1/2" GOMA
1	3505991	TAPA TUBOS ENTRADA CORRIENTE
1	348173PM	CONJUNTO MANDO ELECTRICO
2	350505M	CONJ.PUERTA COCINA DCHA/IZQ.
1	370401C	SOBRE COMPL.B°Mª 2/1 800X750
1	370439C	CONJ.FR.MAN.B°Mª 800
1	C5120219	PILOTO REDONDO ROJO D.5.5
2	C5222269	LATIG.600mm 1/2" MH SUPER MG
2	C5222279	ALARGO GRIFO 100 mm 1/2" M-H
1	C5322579	TERMOSTATO 30-90° TB-09
2	C5421210	RESISTENCIA ADH.B°Mª 1000 W/220
1	C5520800	BORNE PHOENIX VERDE-AMA.UK-10N
2	C5520801	BORNE PHOENIX GRIS UK-10N
1	C5800388	RACORD REDUCCION 3/4"-1/2"
1	C5803379	CODO 1/2"-1/2" H-H
4	C6260511	PATA INOX 130-200 (S_F)

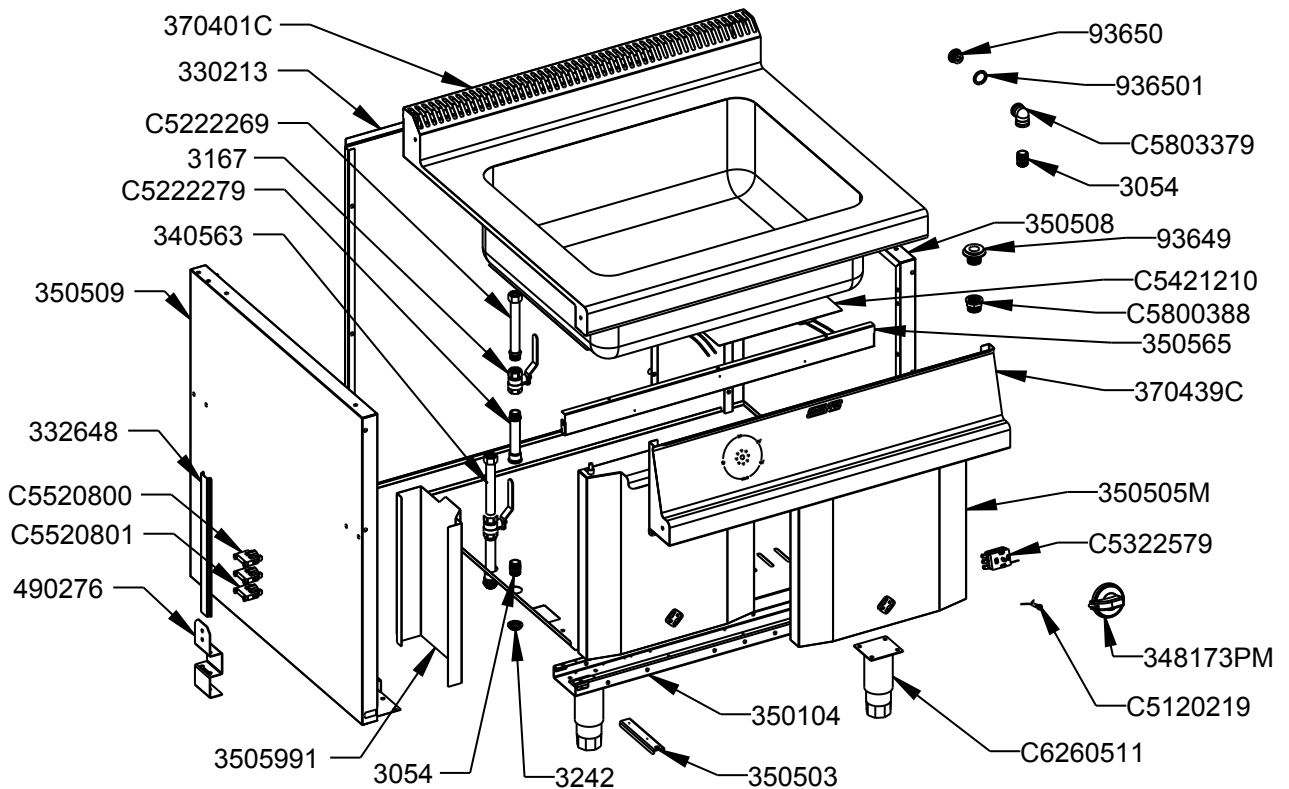

FAMILIA: COCINAS 2008

FECHA: 14/02/11

MODELO: 3704 - RMBE - BM87E

PESO(Kg): 42.292

DENOMINACION:
B°Mª 800x750

ESCALA:
13/200

MATERIAL:
INOX

CODIGO:
3704



Applus®
LGA1
Organismo
Notificado
0370

AENOR
Organismo
Notificado
0099



TOLERANCIAS GENERALES: ± 0.5 mm

QT	COD	DESCRIPCION	FAB.	MATERIAL	DATA	PESO
6	TESTA35	ANGULO TESTATINA 35	SI	INOX 0.6	29/08/07	0.004
2	TESTA70	ANGULO TESTATINA 70	SI	INOX 0.6	29/08/07	0.008
2	TESTA140	ANGULO TESTATINA 140	SI	INOX 0.6	29/08/07	0.016
2	TESTA650	ANGULO TESTATINA 650	SI	INOX 0.6	29/08/07	0.076
1	350563	BASE 800 X 750	SI	INOFER 0.8	21/12/09	3.698
2	350503	BISAGRA	SI	INOFER 1.2	20/09/07	0.067
2	350505M	CONJ.PUERTA COCINA DCHA/IZQ.	SI	INOX	26/05/08	3.467
2	350518	CONTRAPUERTA ARMARIO COCINA	SI	INOFER 1.2	25/02/10	1.975
1	350565	FRONTAL INFERIOR 800	SI	INOFER 0.8	15/06/10	0.394
1	332648	GUIA CONTACTORES 400	SI	GALVA 0.8	30/10/08	0.094
1	350508	LATERAL DERECHO 750	SI	INOFER 0.8	27/02/09	4.447
1	380741	LATERAL DERECHO SOBRE 750	SI	INOFER 1.2	30/11/07	0.324
1	350509	LATERAL IZQUIERDO 750	SI	INOFER 0.8	27/02/09	4.447
1	380740	LATERAL IZQUIERDO SOBRE 750	SI	INOFER 1.2	30/11/07	0.324
2	350104	OMEGA COCINA 800	SI	GALVA 1.5	13/11/08	1.495
2	350505	PUERTA ARMARIO COCINA	SI	INOX 0.8	01/10/07	1.470
1	370401	SOBRE B°Mª 2/1 800X750	SI	INOX 1.2	10/11/08	3.659
1	370401C	SOBRE COMPL.B°Mª 2/1 800X750	SI	INOX	14/02/11	7.533
1	490276	SOPORTE GUIA 332748-REG.MOTOR	SI	GALVA 1.5	03/12/10	0.016
1	3505991	TAPA TUBOS ENTRADA CORRIENTE	SI	INOFER 0.8	15/09/09	0.740
1	380779	TAPETA LATERAL IZQ. FRONTAL	SI	INOFER 1.2	26/06/07	0.121
1	330213	TRASERO 800	SI	INOFER 0.8	07/01/09	4.103
2	C5222279	ALARGO GRIFO 100 mm 1/2" M-H	NO	LATON	26/07/10	0.122
2	C5520801	BORNE PHOENIX GRIS UK-10N	NO	PLAS.	10/01/11	0.017
1	C5520800	BORNE PHOENIX VERDE-AMA.UK-10N	NO	PLAS.	10/01/11	0.017
1	C5803379	CODO 1/2"-1/2" H-H	NO	LATON	01/02/11	0.117
1	348173PM	CONJUNTO MANDO ELECTRICO	NO	BAQ+ABS	10/12/07	0.114
1	370401P	CUBA BAÑO MARIA 2/1	NO	INOX	08/02/11	3.049
1	93649	DESAGUE COMPLETO 3/4"	NO	FE CROMADO	01/01/01	0.087
2	350503P	EJE SUPERIOR PUERTA	NO	FE.ZN	25/05/08	0.013
1	340172P	EMBELLECEDOR MANDO GAS/ELECT.	NO	ABS	10/12/07	0.018
1	93650	ENTRADA AGUA 1/2"	NO	FE CROMADO	31/01/11	0.033
1	936501	JUNTA PLANA 1/2" GOMA	NO	GOMA	31/01/11	0.001
2	C5222269	LATIG.600mm 1/2" MH SUPER MG	NO	INOX	31/01/11	0.218
3	3054	MACHON 1/2"	NO	LATON	31/01/11	0.010
1	348173P	MANDO ELECTRICO	NO	BAQ	10/12/07	0.096
4	C6260511	PATA INOX 130-200 (S_F)	NO	INOX	01/01/09	0.320
1	C5120219	PILOTO REDONDO ROJO D.5.5	NO	CU	14/04/09	0.002
1	C5800388	RACORD REDUCCION 3/4"-1/2"	NO	LATON	01/02/11	0.045
2	C5421210	RESISTENCIA ADH.B°Mª 1000 W/220	NO	SILICONA	01/01/01	0.391
1	C5322579	TERMOSTATO 30-90° TB-09	NO	PLASTICO	09/06/09	0.269
2	1050	TORNILLO ALLEN M5X12 DIN912	NO	INOX	22/05/09	0.004
4	1095	TORNILLO M-5X10 TLR INOX	NO	INOX	01/01/09	0.003
2	3242	TUERCA LATON 1/2"	NO	INOX	27/11/00	0.009
2	3167	VALVULA DE BOLA DE 2 VIAS 1/2"	NO	INOX	01/02/11	0.176



FAMILIA: COCINAS 2008

FECHA: 14/02/11

MODELO: 3704 - RMBE - BM87E

PESO(Kg): 42.292

DENOMINACION:
B°Mª 800x750

ESCALA:
1/10

MATERIAL:
INOX

CODIGO:
3704



Applus®
LGA1
Organismo
Notificado
0370

AENOR
Organismo
Notificado
0099

FUNDADA EN 1878
MAS BAGA
GRANDES COCINAS

EURAST

mac-fin

TOLERANCIAS GENERALES: ± 0.5 mm

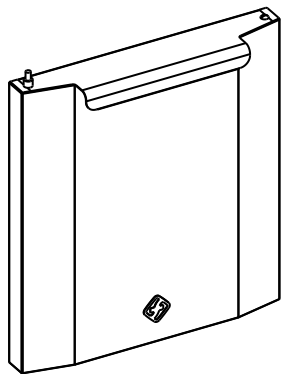

EN LA IMAGEN:
PUERTA IZQ.
CAMBIANDO LOS 4 TORNILLOS
ENTRE SÍ, ES DERECHA.

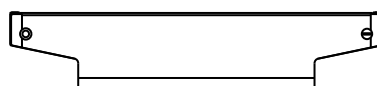
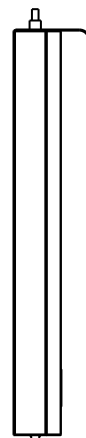
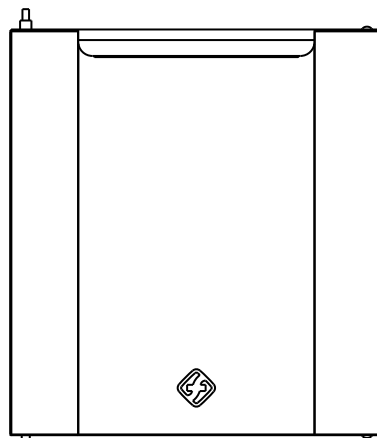

QT.	COD	DESCRIPCION
1	1050	TORNILLO ALLEN M5X12 DIN912
2	1095	TORNILLO M-5X10 TLR INOX
1	350505	PUERTA ARMARIO COCINA
1	350518	CONTRAPUERTA ARMARIO COCINA
1	350503P	EJE SUPERIOR PUERTA

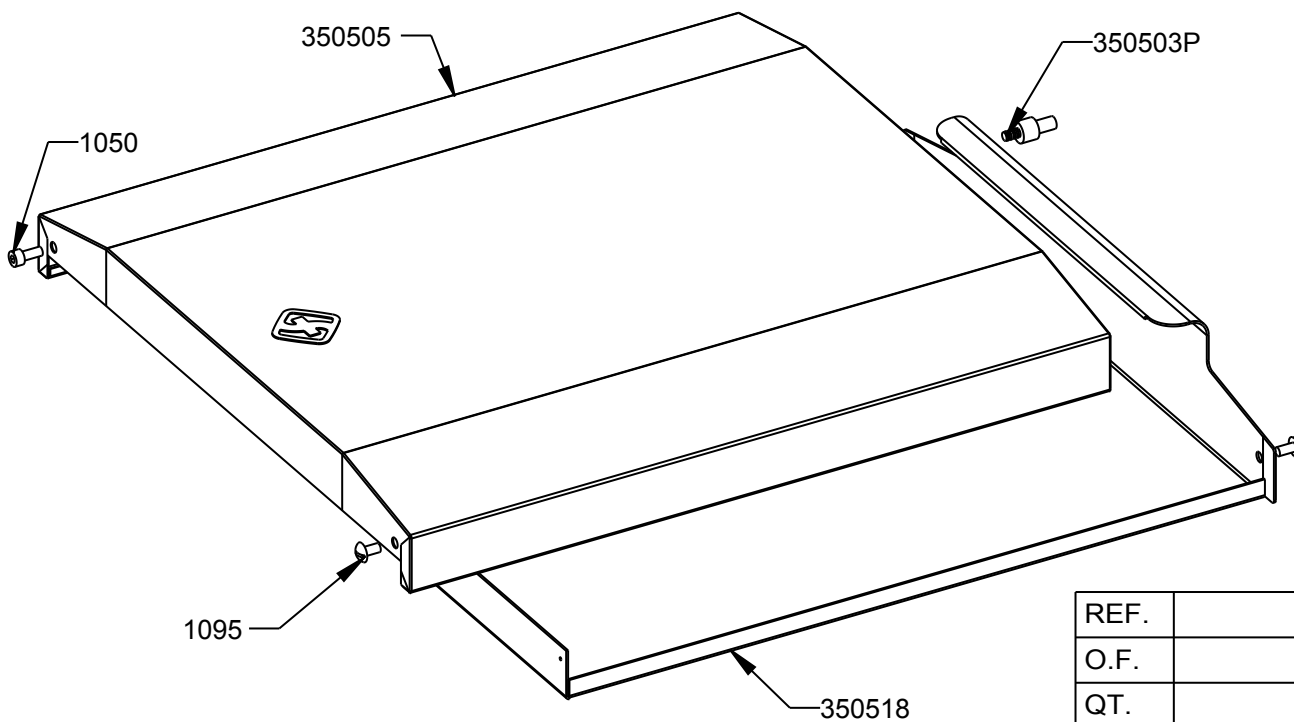

REF.	
O.F.	
QT.	
DEST.	



FAMILIA: COCINAS 2008

FECHA: 26/05/08

MODELO: 3505

PESO(Kg): 3.467

DENOMINACION:
CONJ. PUERTA COCINA DCHA/IZQ.

ESCALA:
1/4

MATERIAL:
INOX

CODIGO:
350505M