

E421 CONTROL PANEL

ITEM	DESCRIPTION	SPARES No.
1	CONTROL PANEL ASSEMBLY	731421010
1.1	RED NEON	735010370
1.2	AMBER NEON	735010380
1.3	CONTROL KNOB C/W STOP	731350001
1.4	CONTROLLER	731350002

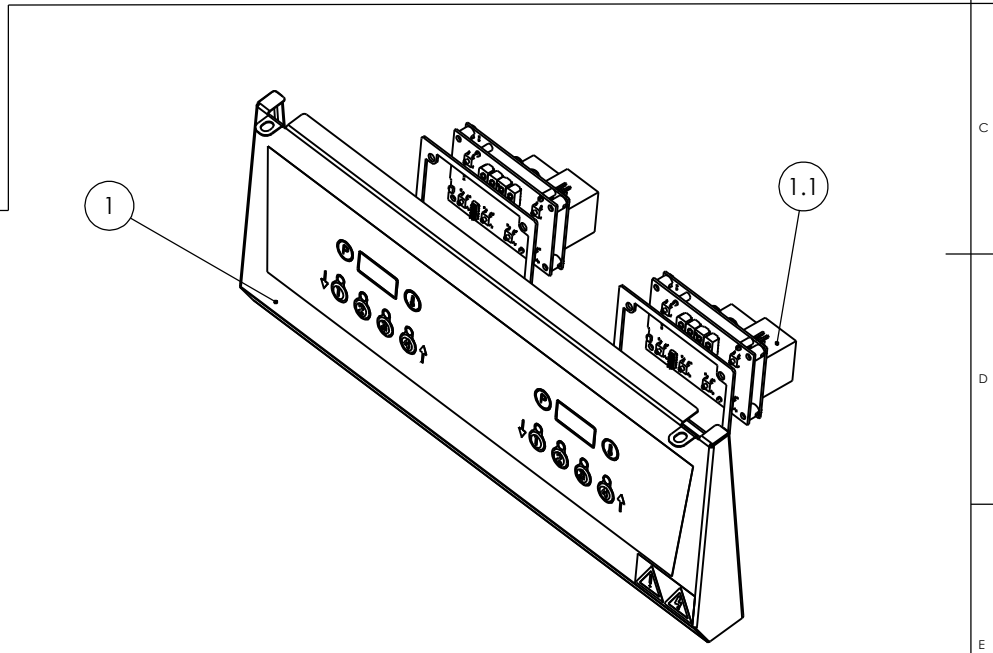

E422 CONTROL PANEL

ITEM	DESCRIPTION	SPARES No.
1	CONTROL PANEL ASSEMBLY	731430002
1.1	CONTROLLER C/W SPACER	731360001

CLEARED FOR PRODUCTION

ISSUE	MOD No	ALTERATION	DRAWN BY	DATE
A	1325	PRODUCTION ISSUE	D. McPherson	13/01/2012

IF IN DOUBT ASK
DO NOT SCALE
FIRST ANGLE PROJECTION

UNLESS OTHERWISE SPECIFIED:
DIMENSIONS ARE IN MILLIMETERS
TOLERANCES:
LINEAR: ±0.5mm
ANGULAR: ±0.5 DEG

DEBUR AND
BREAK SHARP EDGES

WEIGHT: 1199513.24g



DRAWN: D. McPherson	PRODUCT	E421/422 Twin Pan Fryer	
DATE: 13/01/2012	TITLE	SPARES - CONTROL PANELS	
SCALE: 1:3	DRAWING NUMBER	AD49260	ISSUE
MATL:	FINISH:		A
THICKNESS:	PART No:		
BIN No:			

© NO REPRODUCTION OR PUBLICATION OF THIS DRAWING MAY BE MADE AND NO ARTICLE MAY BE MANUFACTURED OR ASSEMBLED IN ACCORDANCE WITH THIS DRAWING WITHOUT PRIOR WRITTEN CONSENT. THIS PROHIBITION IS A TERM OF ANY CONTRACT RELATING TO THIS DRAWING. RIGHTS RESERVED UNDER THE COPYRIGHT ACT 1956 AS AMENDED BY THE DESIGN COPYRIGHT ACT 1968

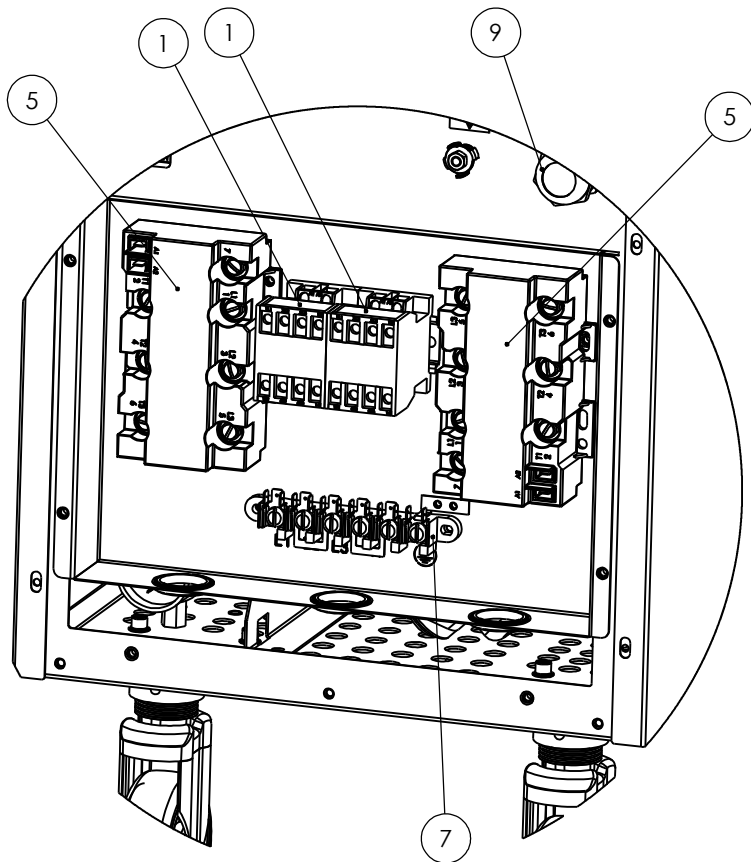

ITEM	DESCRIPTION	UNIT	SPARES No
1	CONTACTOR		734310440
2	FUSE HOLDER		734310510
3	2 AMP ANTI-SURGE FUSE		731050002
4	5 AMP ANTI-SURGE FUSE	FILTER MODELS ONLY	536430009
5	SOLID STATE POWER SWITCH		731350024
6	ROCKER SWITCH		732950006
7	MAINS TERMINAL BLOCK		731000006
8	MAINS INLET CABLE (NOT SHOWN)		731350025
9	MAINS INLET CABLE GLAND C/W NUT		731350026
10	MAIN WIRING LOOM (NOT SHOWN)	FILTER MODELS ONLY	731421004
11	MAIN WIRING LOOM (NOT SHOWN)	NON-FILTER MODELS	731420001
12	CONTROL PANEL WIRING LOOM (NOT SHOWN)	421 ONLY	731420002
13	CONTROL PANEL WIRING LOOM (NOT SHOWN)	422 ONLY	731430001

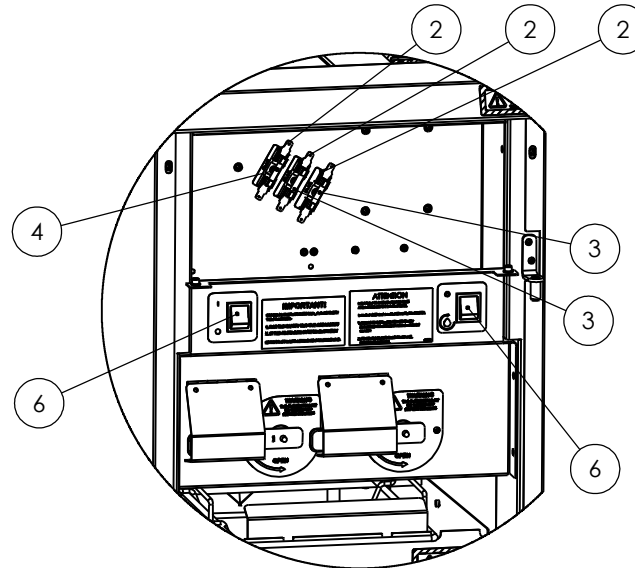

CLEARED FOR PRODUCTION

ISSUE	MOD No	ALTERATION	DRAWN BY	DATE
A	1325	PRODUCTION ISSUE	D. McPherson	16/01/2012

IF IN DOUBT ASK
DO NOT SCALE
FIRST ANGLE PROJECTION

UNLESS OTHERWISE SPECIFIED:
DIMENSIONS ARE IN MILLIMETERS
TOLERANCES:
LINEAR: ±0.5mm
ANGULAR: ±0.5 DEG

DEBUR AND
BREAK SHARP EDGES

WEIGHT: 1191329.65g

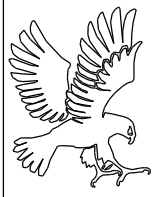

DRAWN: D. McPherson	PRODUCT	E421/422 TWIN PAN FRYER	
DATE: 16/12/2011	TITLE	SPARES - ELECTRICS	
SCALE:	DRAWING NUMBER	AD49192	
MATL:	ISSUE	A	
THICKNESS:	FINISH:		
BIN No:	PART No:		

© NO REPRODUCTION OR PUBLICATION OF THIS DRAWING MAY BE MADE AND NO ARTICLE MAY BE MANUFACTURED OR ASSEMBLED IN ACCORDANCE WITH THIS DRAWING WITHOUT PRIOR WRITTEN CONSENT. THIS PROHIBITION IS A TERM OF ANY CONTRACT RELATING TO THIS DRAWING. RIGHTS RESERVED UNDER THE COPYRIGHT ACT 1956 AS AMENDED BY THE DESIGN COPYRIGHT ACT 1968

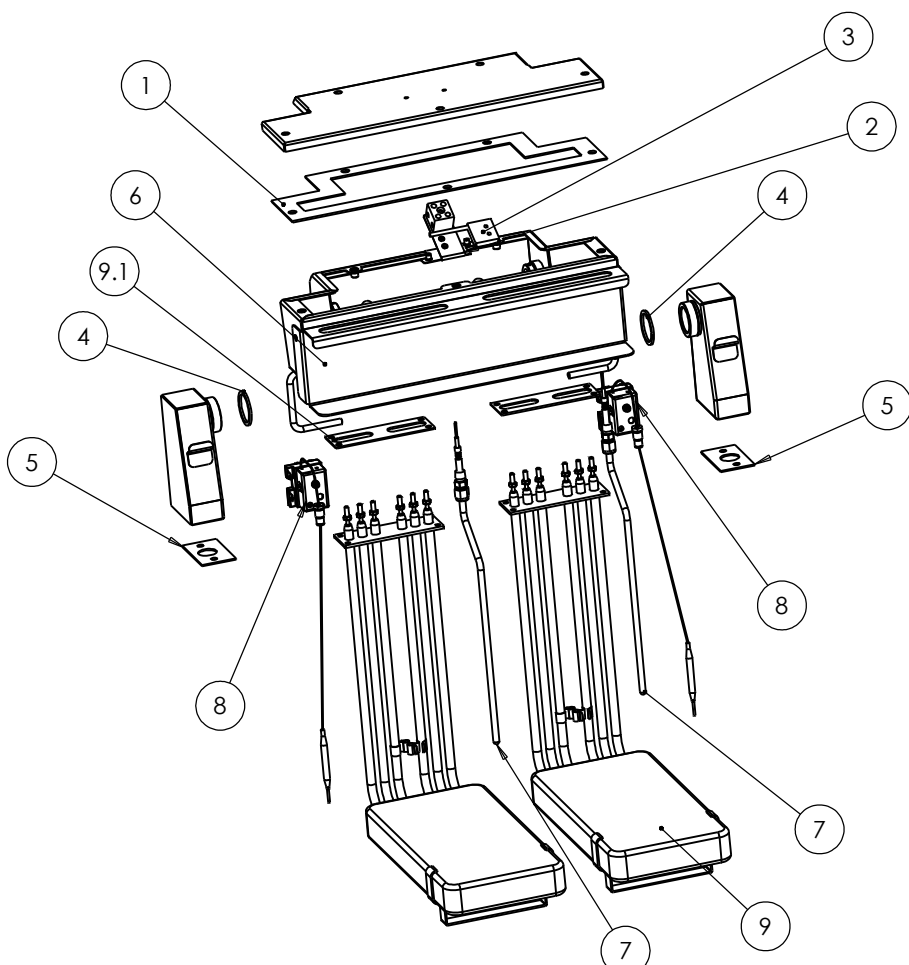

ITEM	DESCRIPTION	SPARES No
1	ELEMENT BOX LID GASKET	731350015
2	TILT SWITCH BRACKET	731350016
3	TILT SWITCH	735750014
4	ELEMENT BOX CABLE GASKET	731350017
5	ELEMENT BOX SUPPORT GASKET	731350018
6	BASKET HANGING RAIL	731350019
7	THERMISTOR PROBE C/W FITTINGS	731350020
8	SAFETY STAT C/W FITTINGS	731350021
9	ELEMENT C/W GASKET	731350022
9.1	ELEMENT GASKET	731350023

CLEARED FOR PRODUCTION

ISSUE	MOD No	ALTERATION	DRAWN BY	DATE
A	1325	PRODUCTION ISSUE	D. McPherson	10/01/2012

IF IN DOUBT ASK
DO NOT SCALE
FIRST ANGLE PROJECTION

UNLESS OTHERWISE SPECIFIED:
DIMENSIONS ARE IN MILLIMETERS
TOLERANCES:
LINEAR: ±0.5mm
ANGULAR: ±0.5 DEG

DEBUR AND
BREAK SHARP EDGES

WEIGHT: 1199897.68g



DRAWN: D. McPherson	PRODUCT	E421/422 TWIN PAN FRYER	
DATE: 15/12/2011	TITLE	SPARES - ELEMENTS / HOUSING	
SCALE:	DRAWING NUMBER	AD49190	
MATL:	ISSUE	A	
THICKNESS:	FINISH:		
BIN No:	PART No:		

© NO REPRODUCTION OR PUBLICATION OF THIS DRAWING MAY BE MADE AND NO ARTICLE MAY BE MANUFACTURED OR ASSEMBLED IN ACCORDANCE WITH THIS DRAWING WITHOUT PRIOR WRITTEN CONSENT. THIS PROHIBITION IS A TERM OF ANY CONTRACT RELATING TO THIS DRAWING. RIGHTS RESERVED UNDER THE COPYRIGHT ACT 1956 AS AMENDED BY THE DESIGN COPYRIGHT ACT 1968

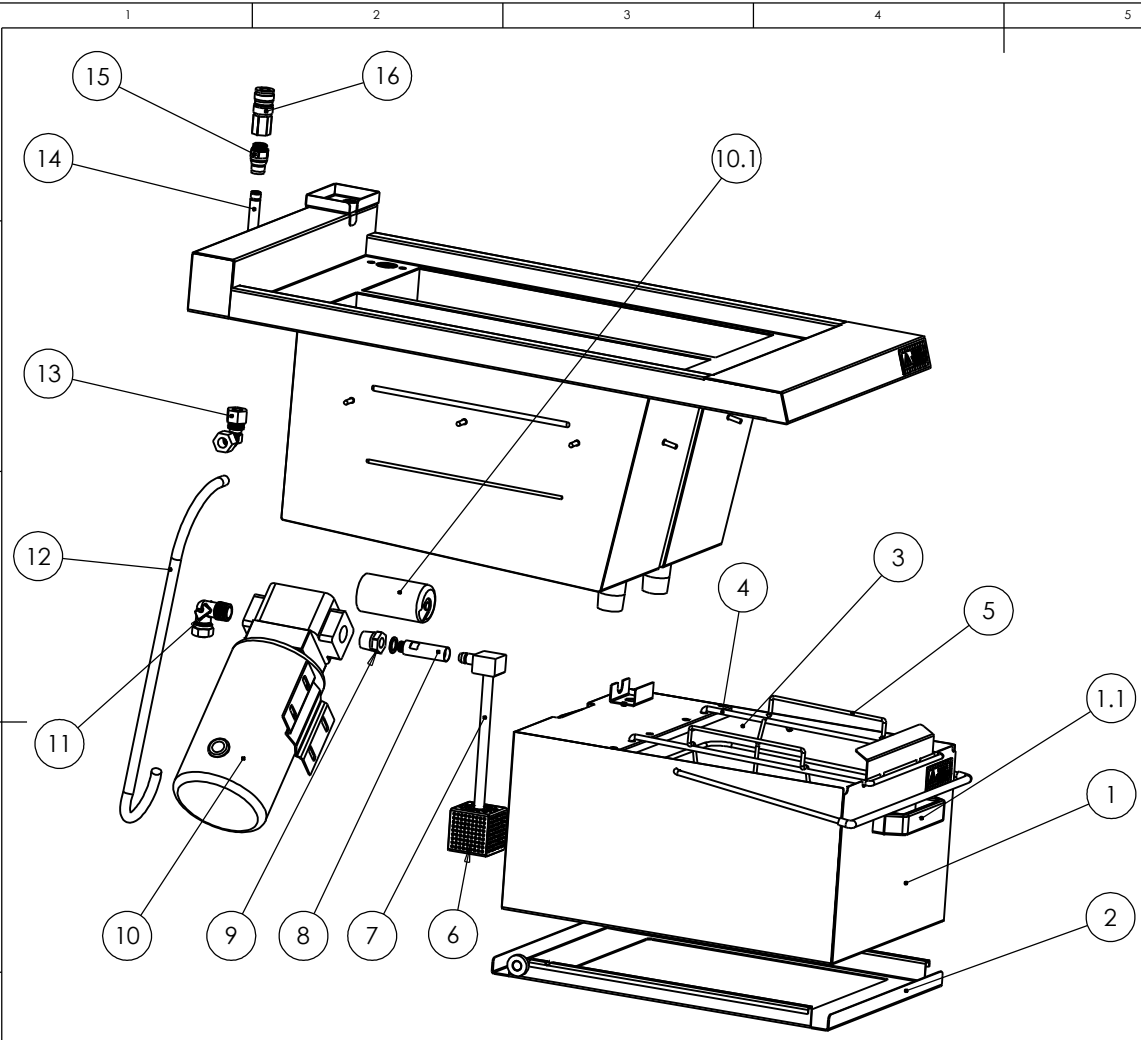

ITEM	DESCRIPTION	SPARES No
1	OIL CONTAINER ASSEMBLY	731350056
1.1	OIL CONTAINER FRONT HANDLE	731350030
2	OIL CONTAINER CARRIER	535770028
3	FINE MESH FILTER	737101159
4	FINE MESH FILTER WIRE SUPPORT	737101143
5	BASKET FILTER	731350031
6	SUCTION PIPE FILTER	731350032
7	SUCTION PIPE C/W 'O' RING	731350033
7.1	SUCTION PIPE 'O' RING (NOT SHOWN)	731350034
8	OIL INLET NOZZLE C/W WASHER	731350035
9	REDUCER	731350036
10	OIL PUMP	731350037
10.1	OIL PUMP CAPACITOR	731350038
11	PUMP ELBOW	536300039
12	OIL PUMP OUTLET PIPE	537950190
13	OIL RETURN ELBOW	536300040
14	S/S RIGID OIL PIPE	731421001
15	PUSH IN FITTING 3/8" MALE	731421002
16	QUICK RELEASE CONNECTOR 3/8"	731420003

CLEARED FOR PRODUCTION

ISSUE	MOD No	ALTERATION	DRAWN BY	DATE
A	1325	Production Issue	D. McPherson	12/01/2012

IF IN DOUBT ASK
DO NOT SCALE
FIRST ANGLE PROJECTION

UNLESS OTHERWISE SPECIFIED:
DIMENSIONS ARE IN MILLIMETERS
TOLERANCES:
LINEAR: ±0.5mm
ANGULAR: ±0.5 DEG

DEBUR AND
BREAK SHARP EDGES

WEIGHT: 1201620.66g



DRAWN: D. McPherson	PRODUCT	E421/2F TWIN PAN FRYER	
DATE: 12/01/2012	TITLE	SPARES - FILTRATION	
SCALE: 1:6	MATL:	DRAWING NUMBER	ISSUE
THICKNESS:	FINISH:	AD49258	A
BIN No:	PART No:		

© NO REPRODUCTION OR PUBLICATION OF THIS DRAWING MAY BE MADE AND NO ARTICLE MAY BE MANUFACTURED OR ASSEMBLED IN ACCORDANCE WITH THIS DRAWING WITHOUT PRIOR WRITTEN CONSENT. THIS PROHIBITION IS A TERM OF ANY CONTRACT RELATING TO THIS DRAWING. RIGHTS RESERVED UNDER THE COPYRIGHT ACT 1956 AS AMENDED BY THE DESIGN COPYRIGHT ACT 1968

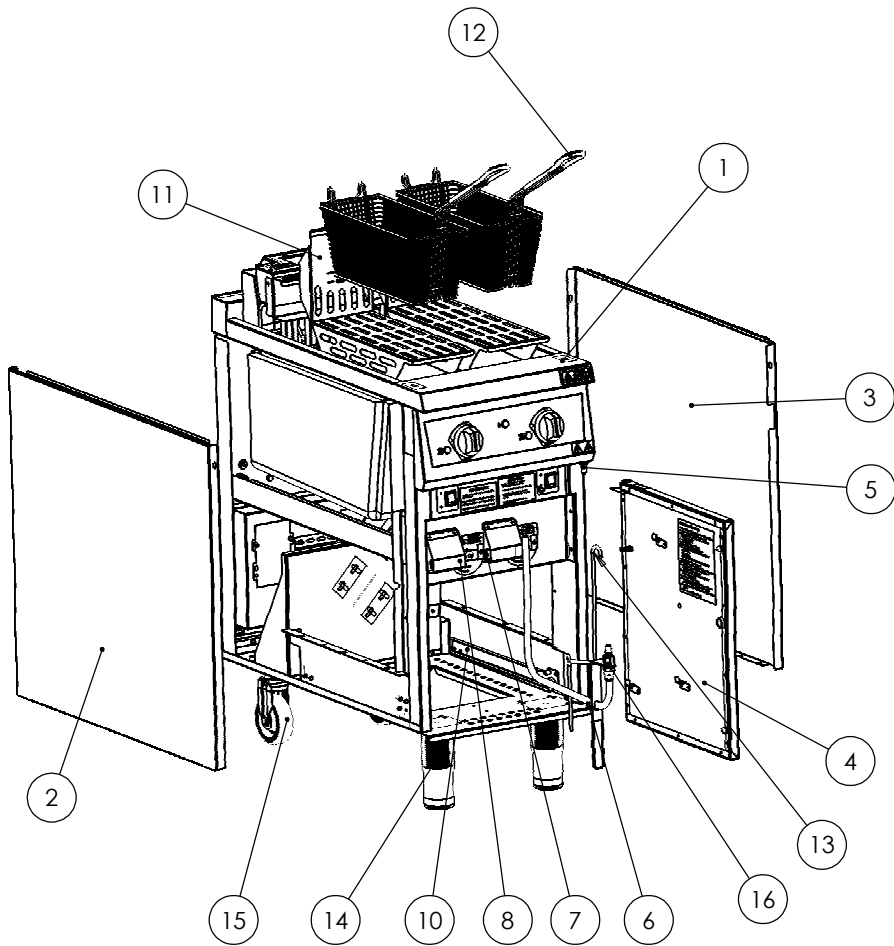

ITEM	DESCRIPTION	SPARES No
1	HOB / PAN ASSEMBLY C/W DRAIN VALVE	731421005
2	LH OUTER SIDE	731350004
3	RH OUTER SIDE	731350005
4	DOOR ASSEMBLY	731421006
5	TOP DOOR HINGE	536430108
6	BOTTOM DOOR HINGE PIN	536430109
7	DRAIN HANDLE	731421007
8	DRAIN HANDLE FLAP	731350008
9	LH BUCKET RUNNER (NOT SHOWN)	731350009
10	RH BUCKET RUNNER	731350010
11	ELEMENT GUARD	731421008
12	CHIP BASKET	536430126
13	DRAIN PROD / LIFTING TOOL	731350012
14	ADJUSTABLE FEET	731350013
15	CASTORS	731350014
16	Oil Return Pipe Assy	731421009

CLEARED FOR PRODUCTION

ISSUE	MOD No	ALTERATION	DRAWN BY	DATE
A	1325	Production Issue	D. McPherson	10/01/2012

IF IN DOUBT ASK
DO NOT SCALE
FIRST ANGLE PROJECTION

UNLESS OTHERWISE SPECIFIED:
DIMENSIONS ARE IN MILLIMETERS
TOLERANCES:
LINEAR: ±0.5mm
ANGULAR: ±0.5 DEG

DEBUR AND
BREAK SHARP EDGES

WEIGHT: 1201620.66g

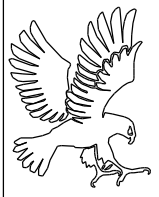

DRAWN: D. McPherson	PRODUCT	E421/2F Twin Pan Fryer	
DATE: 10/01/2012	TITLE	SPARES - MAIN BODY	
SCALE: 1:20	MATL:	DRAWING NUMBER	ISSUE
THICKNESS:	FINISH:	AD49253	A
BIN No:	PART No:		

© NO REPRODUCTION OR PUBLICATION OF THIS DRAWING MAY BE MADE AND NO ARTICLE MAY BE MANUFACTURED OR ASSEMBLED IN ACCORDANCE WITH THIS DRAWING WITHOUT PRIOR WRITTEN CONSENT. THIS PROHIBITION IS A TERM OF ANY CONTRACT RELATING TO THIS DRAWING. RIGHTS RESERVED UNDER THE COPYRIGHT ACT 1956 AS AMENDED BY THE DESIGN COPYRIGHT ACT 1968