



IC 18

LIST OF THE EXPLODED VIEWS



SHELL ASSY

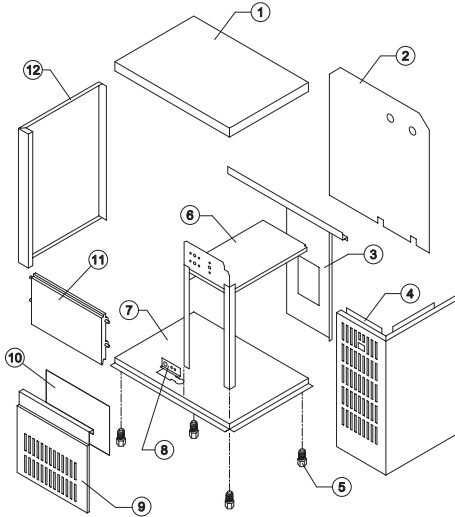

COOLING SYSTEM

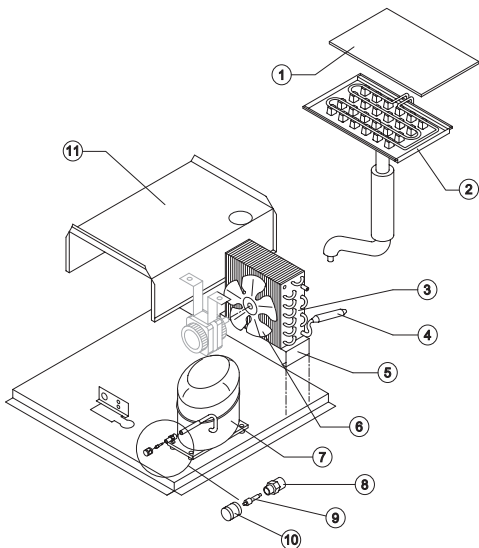

HYDRAULIC CIRCUIT

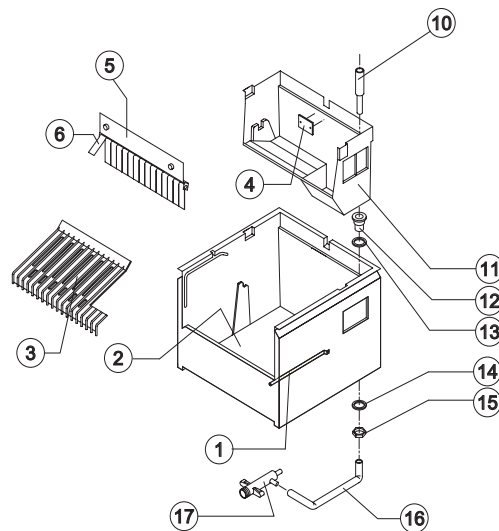

SPRAYER PUMP

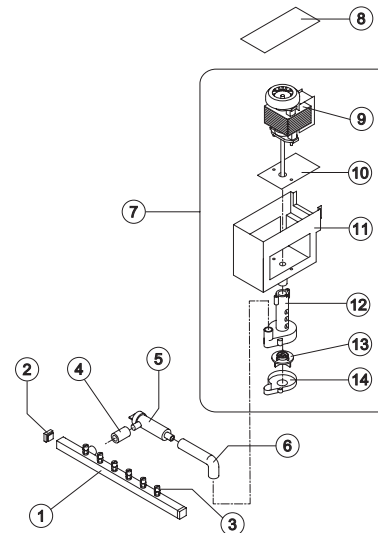

ELECTRIC PARTS

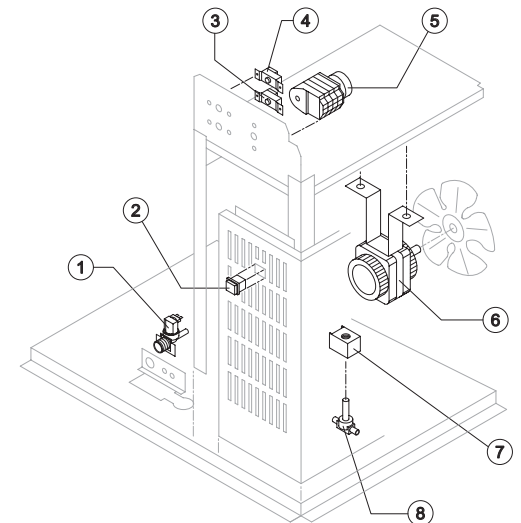

Rev. 3 - 20/10/2003



IC 18

SHELL ASSY

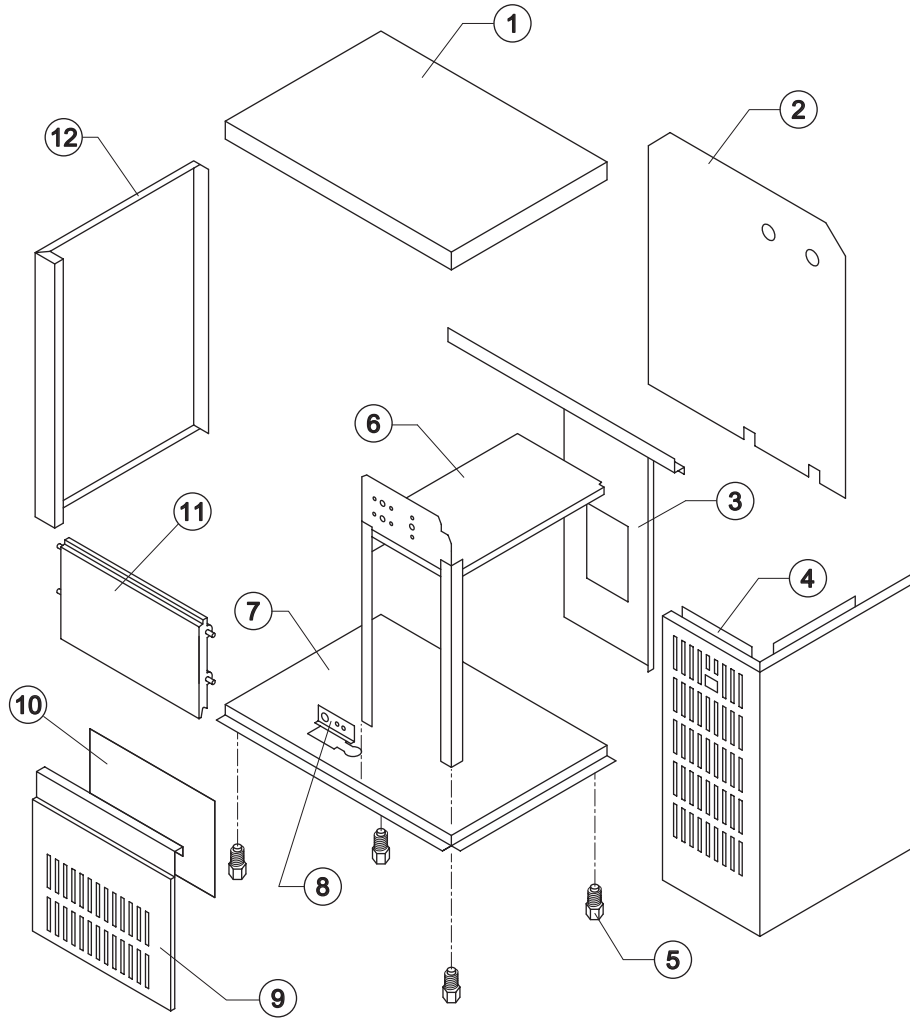

Ref.	Spare Description	Code
1	Top Assembly	C22199
2	Back Panel	21161
3	Back Frame	21156
4	Right & Front Panel (Fan Side)	22308
5	Foot	10017
6	Fan Motor & Electrical Components Support Plate	22301
7	Base Plate	21105
8	Support (Watervalue & Discharge)	21149
9	Front Panel	22307
10	Filtering Panel	18074
11	Blue Door	10081
12	Left Side	22309

Rev. 3 - 20/10/2003

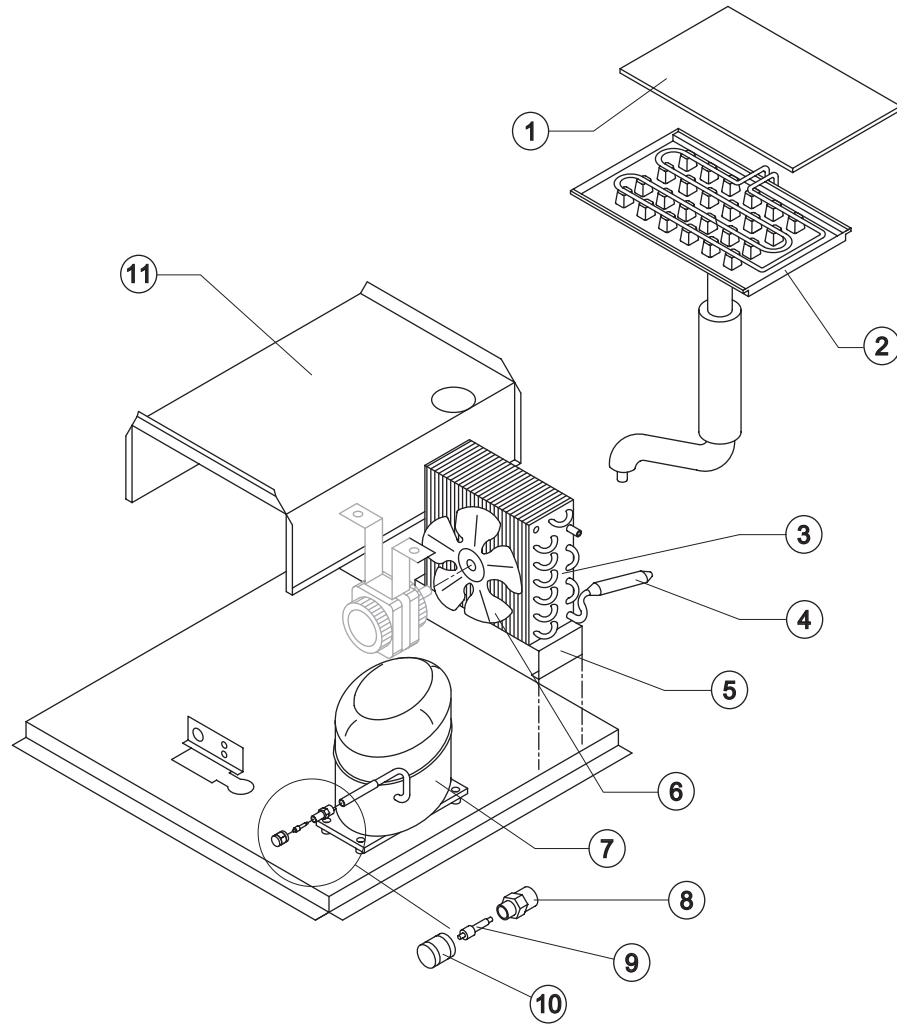

Ref.	Spare Description	Code
1	Evaporator Cover	10076
2	Evaporator	D10079
3	Air Condenser	20094
4	Molecular Drier	14009
5	Air Condenser Support	21155
6	Suction Impeller	20095
7	Compressor	See Table
8	Vacuum-Charge Valve Body	14007
9	Vacuum-Charge Valve Device	14005
10	Vacuum-Charge Valve Plug	14006
11	Bin Support Saddle	21154

Ref. 7 - Compressor

Tension	Code
220/240V 50 Hz	23436
220/230V 60 Hz	23494
110/115V 60 Hz	23446



IC 18

HYDRAULIC CIRCUIT

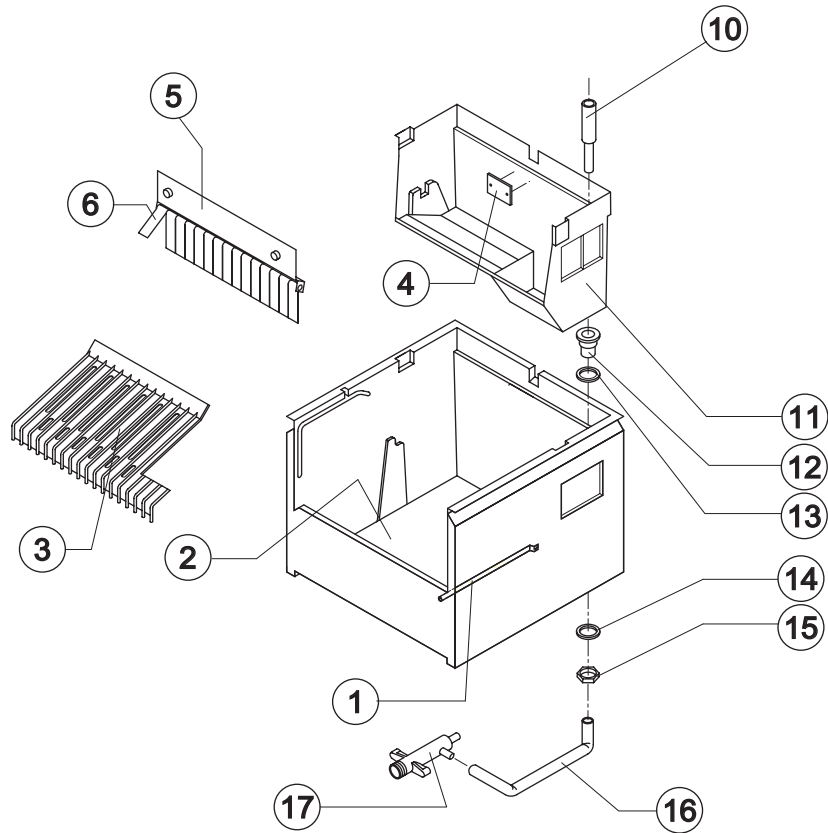

Ref.	Spare Description	Code
1	Bulbe Thermostat Tube	20520
2	Foamed Basin	11016/E
3	Ice Cubes Slide	10136
4	Slide Keep Plate	10142
5	Flags Support Assy	C22106
6	Flag	10005
10	Overflow Pipe	13028
11	Inner Basin	10064
12	Plastic Nipple Water Outlet	10007
13	Silicone Gasket	13006
14	Semirigid Polyethylene Gasket	13007
15	Bin Discharge Nut	10096
16	Water Discharge Pipe	13065
17	Discharge Manifold	10006

Rev. 3 - 20/10/2003



IC 18

SPRAYER PUMP

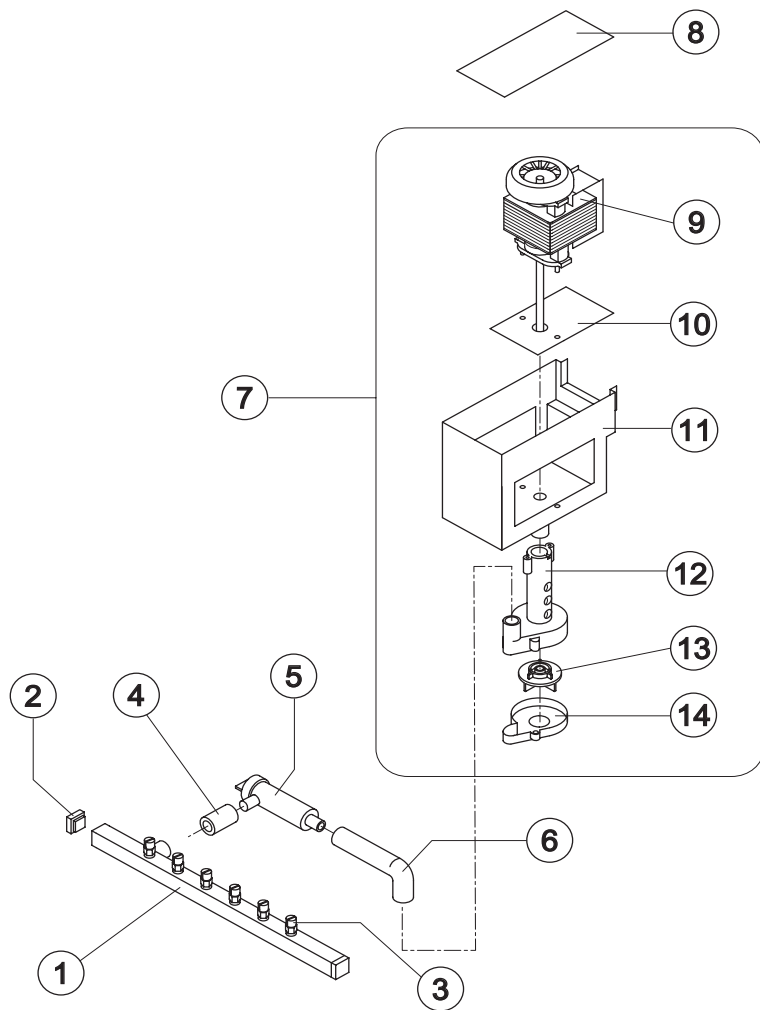

Ref.	Spare Description	Code
1	Sprayers Bar Assembly	C20147
2	Sprayers Bar Plug	10012
3	Sprayer	D20002
4	Filter-Sprayers Bar Connection Pipe	13056
5	Pump Filter	10139
6	Pump-Filter Connection Pipe	13055
7	Pump Assy	See Table
8	Pump Cover	22096
9	Pump Motor	See Table
10	Heat Dissipator	22430
11	Pump Motor Container	10073
12	Pump Body	10065
13	Pump Impeller	10066
14	Diffuser	10067

Ref. 7 - Pump Assy

Tension	Code
220/240V 50 Hz	C23076
220/230V 60 Hz	C23270
110/115V 60 Hz	C23271

Ref. 9 - Pump Motor

Tension	Code
220/240V 50 Hz	23073
220/230V 60 Hz	23187
110/115V 60 Hz	23188

Rev. 3 - 20/10/2003



Rev. 3 - 20/10/2003

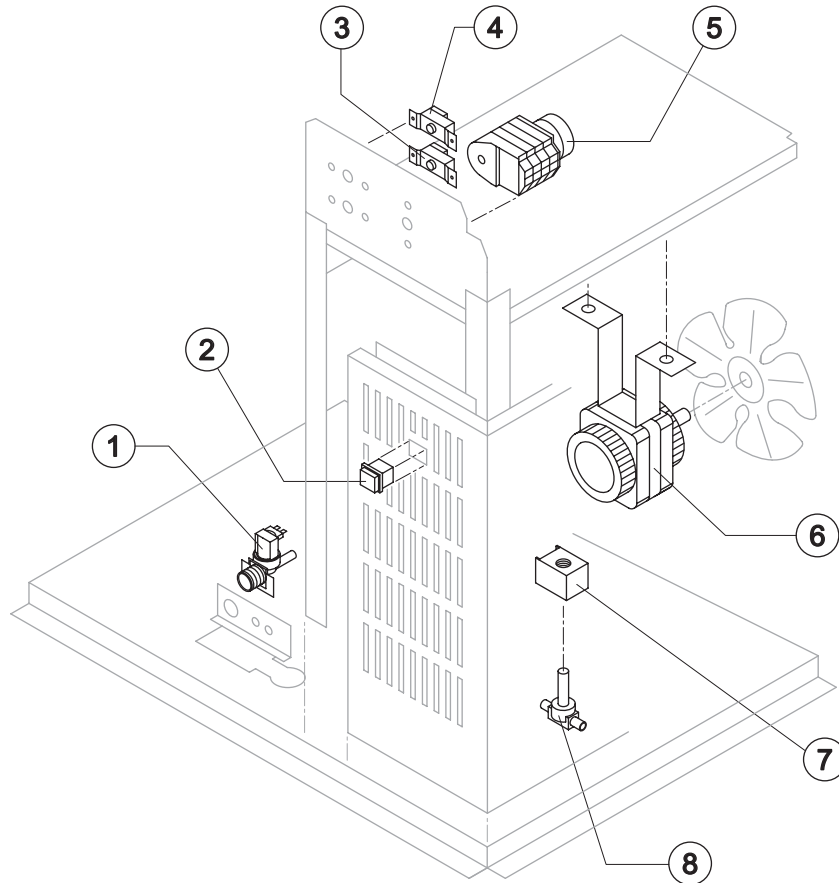

Ref.	Spare Description	Code
1	Inlet Watervalue 1 Way	See Table
2	Green Light Switch	23327
3	Evaporator Thermostat	23591
4	Bin Thermostat	23005
5	Timer	See Table
6	Fan Motor	See Table
7	Hot Gas Coil	See Table
8	Hot Gas Valve Body	20410

Ref. 1 - Inlet Watervalue 1 Way

Tension	Code
220/240V 50 Hz	23300
220/230V 60 Hz	23300
110/115V 60 Hz	23415

Ref. 5 - Timer

Tension	Code
220/240V 50 Hz	23247
220/230V 60 Hz	23247
110/115V 60 Hz	23258

Ref. 6 - Fan Motor

Tension	Code
220/240V 50 Hz	23029
220/230V 60 Hz	23029
110/115V 60 Hz	23683

Ref. 7 - Hot Gas Coil

Tension	Code
220/240V 50 Hz	23091
220/230V 60 Hz	23091
110/115V 60 Hz	23256