



# IC 24

# LIST OF THE EXPLODED VIEWS



## SHELL ASSY

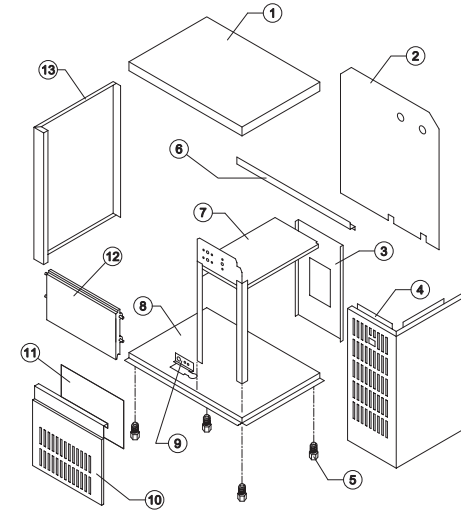

## COOLING SYSTEM

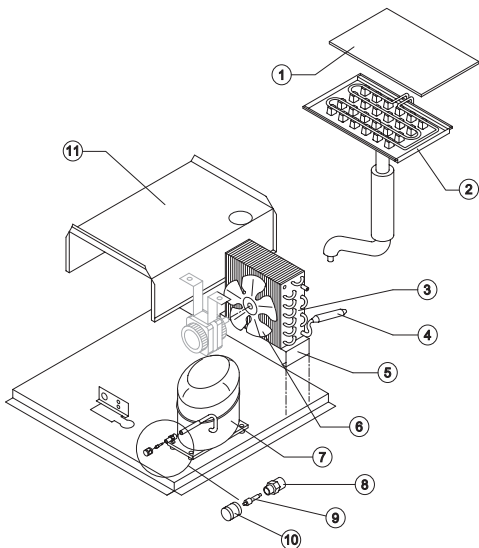

## HYDRAULIC CIRCUIT

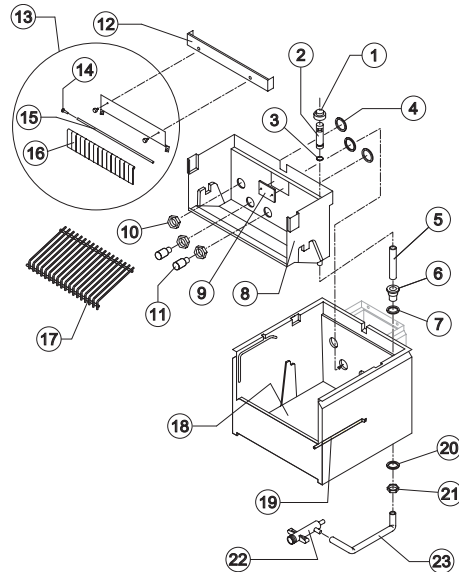

## SPRAYER PUMP

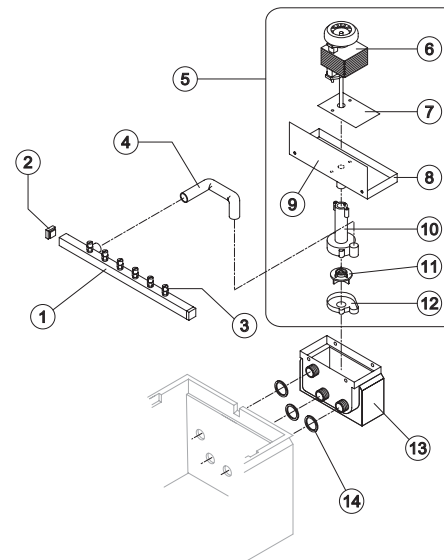

## ELECTRIC PARTS

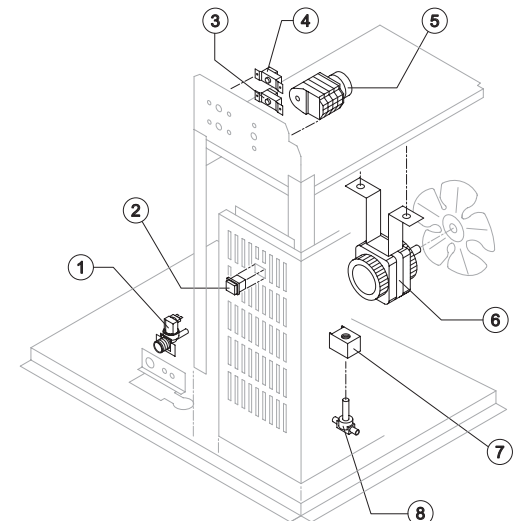

Rev. 1 - 12/6/2002



# IC 24

# SHELL ASSY

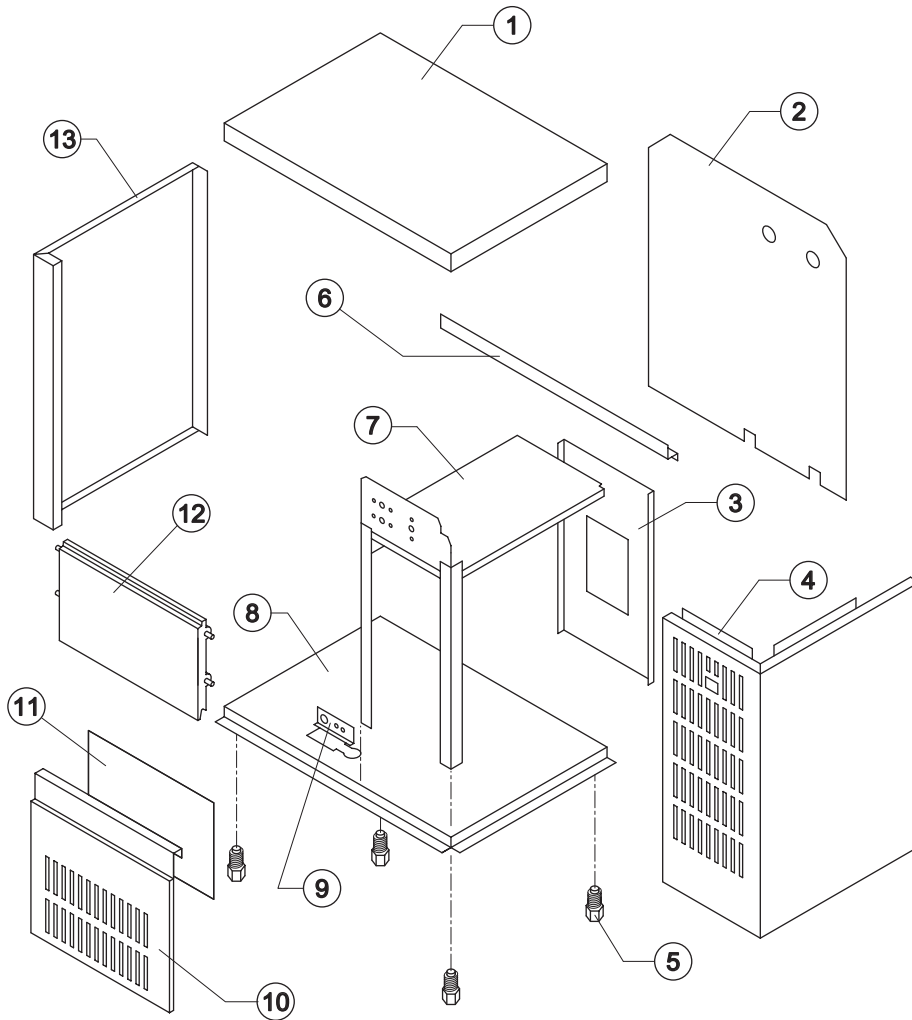

Ref.	Spare Description	Code
1	Top Assembly	C22298
2	Back Panel	21152
3	Back Plate	21151
4	Right & Front Panel (Fan Side)	22297
5	Foot	10017
6	Cross Fixing Panels	21163
7	Fan Motor & Electrical Components Support Plate	22296
8	Base Plate	21153
9	Support (Watervalue & Discharge)	21149
10	Front Panel	22300
11	Filtering Panel	18075
12	Door Assy	C10303
13	Left Side	22299

Rev. 1 - 12/6/2002

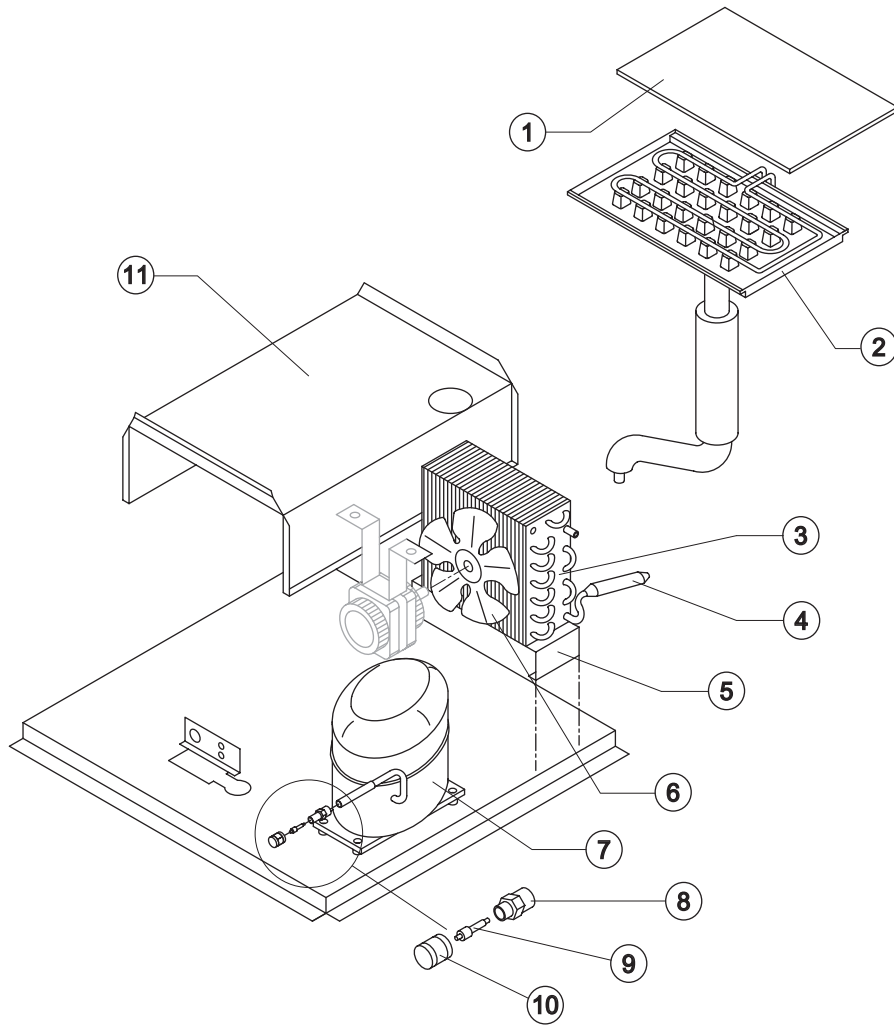

Ref.	Spare Description	Code
1	Evaporator Cover	10008
2	Evaporator	See Table
3	Air Condenser	20260
4	Molecular Drier	14009
5	Air Condenser Support	21148
6	Suction Fan	20095
7	Compressor	See Table
8	Vacuum-Charge Valve Body	14007
9	Vacuum-Charge Valve Device	14005
10	Vacuum-Charge Valve Plug	14006
11	Bin Support Saddle	21150

### Ref. 2 - Evaporator

Kind of Cube	Code
18 g. (Standard)	D10045
33 g. (Big)	-
13 g. (Small)	D10171

### Ref. 7 - Compressor

Tension	Refr. R404A	Refr. R22
220/240V 50 Hz	23436	23197
220/230V 60 Hz	23494	23346
110/115V 60 Hz	23446	23368



# IC 24

# HYDRAULIC CIRCUIT

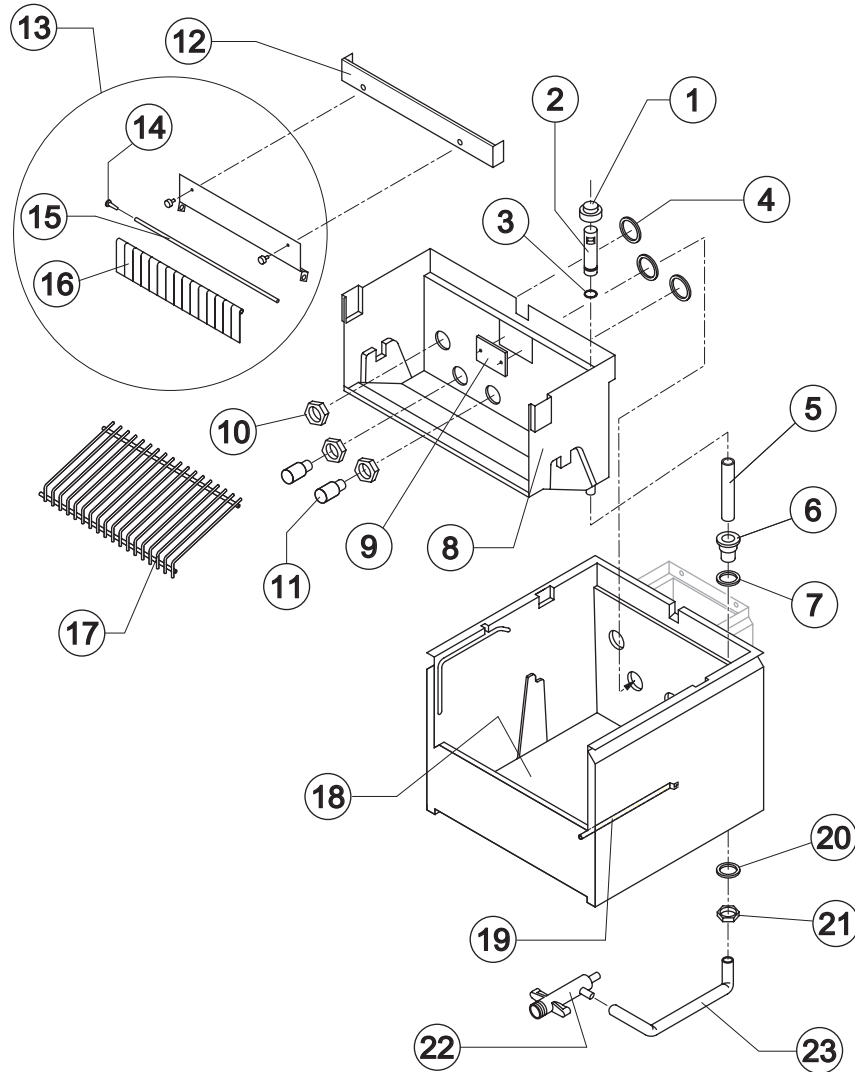

Ref.	Spare Description	Code
1	Overflow Cap	10305
2	Overflow Pipe	10133
3	OR Gasket for Overflow Pipe	20233
4	Silicone Seal for Pump Basin	13069
5	Overflow Pipe	Current Version 13105
5	Overflow Pipe	Till s/n. 65042 13001
6	Plastic Nipple Water Outlet	10007
7	Silicone Gasket	13006
8	Inner Basin	10158
9	Slide Keep Plate	10009
10	Nut for Basin Connections	10159
11	Pump Suction Filter	20005
12	Evaporator Holder	See Table -
13	Flags Support Assy	C22034
14	Flags Rod Clip	10010
15	Flags Rod	12003
16	Flag	10005
17	Ice Cubes Slide	See Table -
18	Foamed Basin	See Table -
19	Bulbe Thermostat Tube	Current Version 20520
19	Bulbe Thermostat Tube	Till s/n. 94517 20008
20	Semirigid Polyethylene Gasket	13007
21	Bin Discharge Nut	10096
22	Discharges Manifold	10006
23	Water Discharge Pipe	13066

### Ref. 12 - Evaporator Holder

Kind of Cube	Code
18 g. (Standard)	22005
33 g. (Big)	-
13 g. (Small)	22228

### Ref. 17 - Ice Cubes Slide

Kind of Cube	Code
18 g. (Standard)	D12001
33 g. (Big)	-
13 g. (Small)	D12046

### Ref. 18 - Foamed Basin

Kind of Cube	Code
18 g. (Standard)	C11121
33 g. (Big)	-
13 g. (Small)	C11121S

Rev. 1 - 12/6/2002

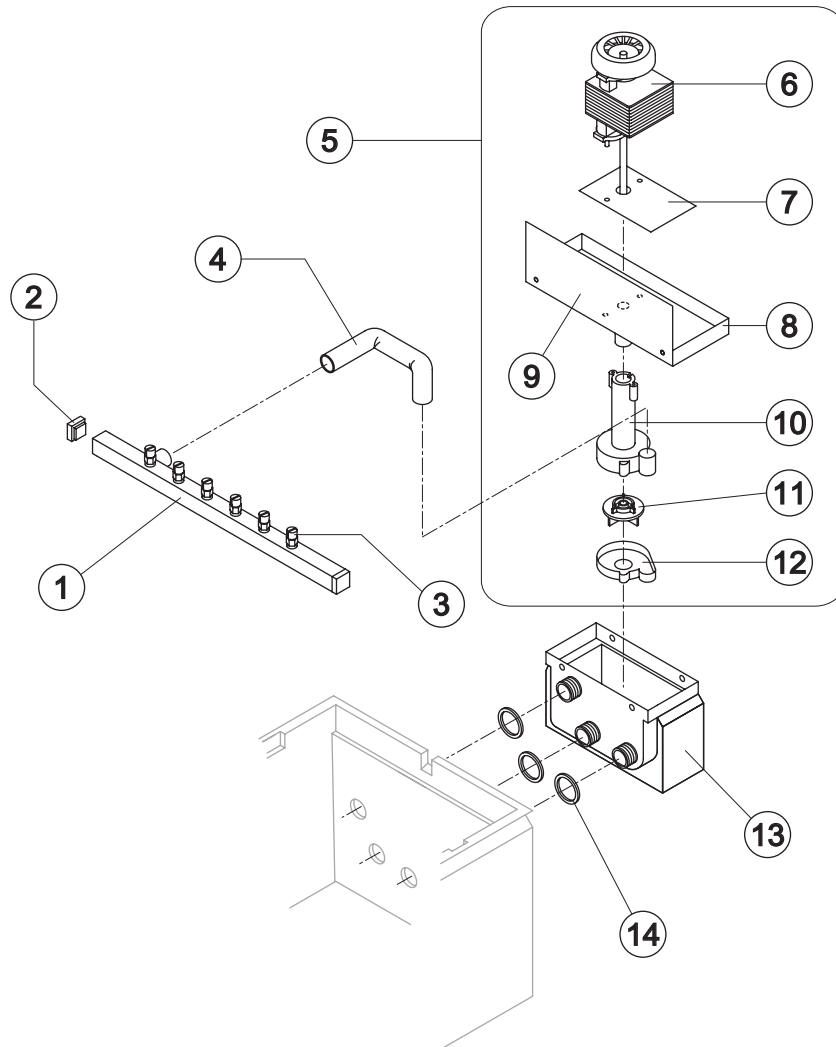

Ref.	Spare Description	Code
1	Sprayers Bar Assembly	See Table
2	Sprayers Bar plug	10012
3	Sprayer	D20002
4	Pump Delivery Pipe	13068
5	Pump Assembly	See Table
6	Pump Motor	See Table
7	Heat Dissipator	22430
8	Pump Motor Holder	10161
9	Basin/Pump Fender Case	22763
10	Pump Body	10065
11	Pump Imeller	10066
12	Diffuser	10067
13	Insulated Pump Basin	C11048
14	Silicone Seal for Pump Basin	13069

### Ref. 1 - Sprayers Bar Assembly

Kind of Cube	Code
18 g. (Standard)	C20572
33 g. (Big)	-
13 g. (Small)	C20570

### Ref. 5 - Pump Assembly

Tension	Code
220/240V 50 Hz	C23254
220/230V 60 Hz	C23416
110/115V 60 Hz	C23417

### Ref. 6 - Pump Motor

Tension	Code
220/240V 50 Hz	23073
220/230V 60 Hz	23187
110/115V 60 Hz	23188



Rev. 1 - 12/6/2002

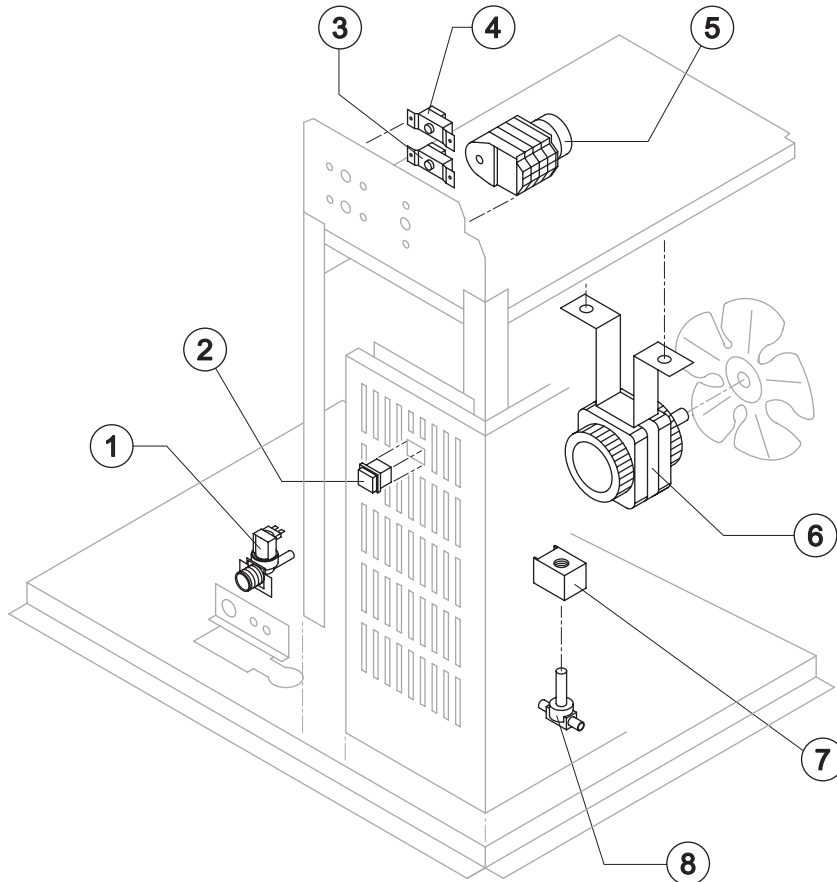

Ref.	Spare Description	Code
1	Inlet Watervalue 1 Way	See Table
2	Green Light Switch	23327
3	Evaporator Thermostat	23591
4	Bin Thermostat	23005
5	Timer	See Table
6	Fan Motor	See Table
7	Hot Gas Coil	See Table
8	Hot Gas Valve Body	20410

**Ref. 1 - Inlet Watervalue 1 Way**

Tension	Code
220/240V 50 Hz	23300
220/230V 60 Hz	23300
110/115V 60 Hz	23415

**Ref. 6 - Fan Motor**

Tension	Code
220/240V 50 Hz	23029
220/230V 60 Hz	23029
110/115V 60 Hz	23265

**Ref. 5 - Timer**

Tension	18g Cube	33g Cube	13g Cube
220/240V 50 Hz	23222	-	23247
220/230V 60 Hz	23248	-	23247
110/115V 60 Hz	23259	-	23258

**Ref. 7 - Hot Gas Coil**

Tension	Code
220/240V 50 Hz	23091
220/230V 60 Hz	23091
110/115V 60 Hz	23256