



Applus®
LGA1
Organismo
Notificado
0370

AENOR
Organismo
Notificado
0099



TOLERANCIAS GENERALES: ±0.5 mm

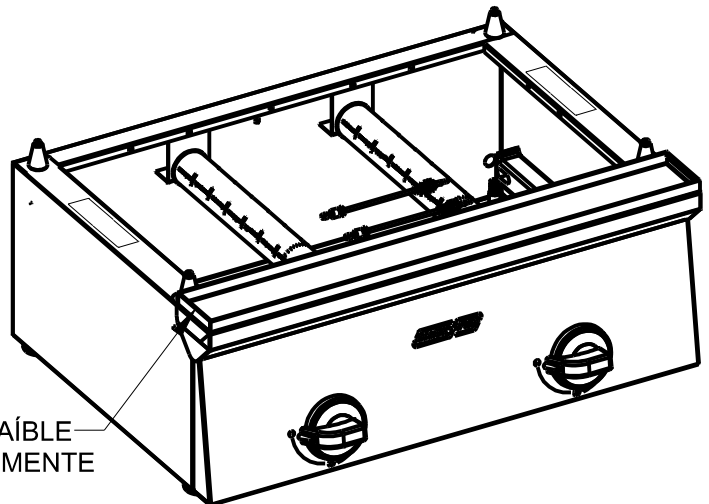
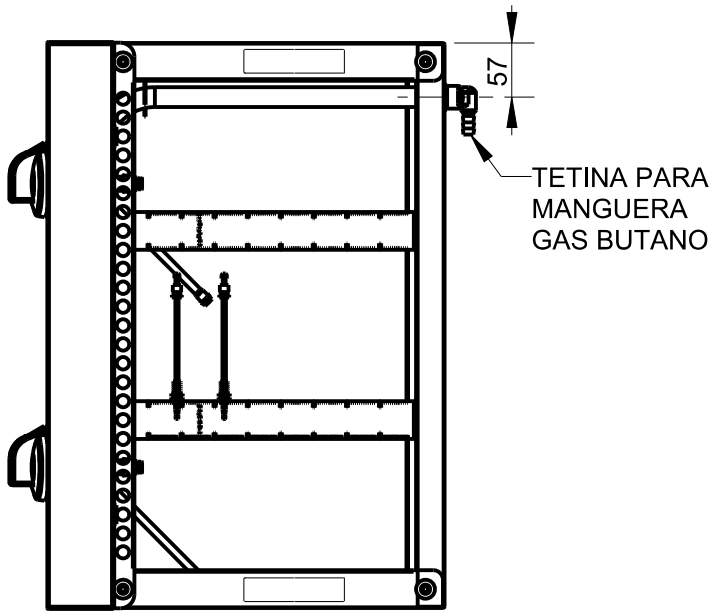
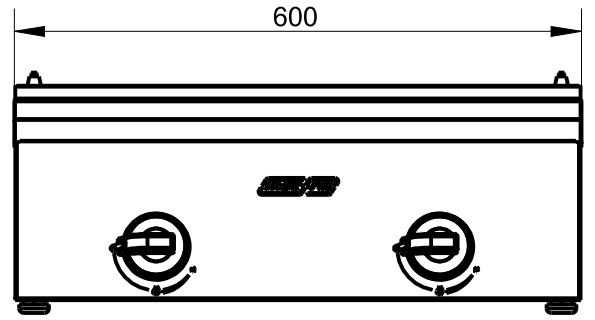
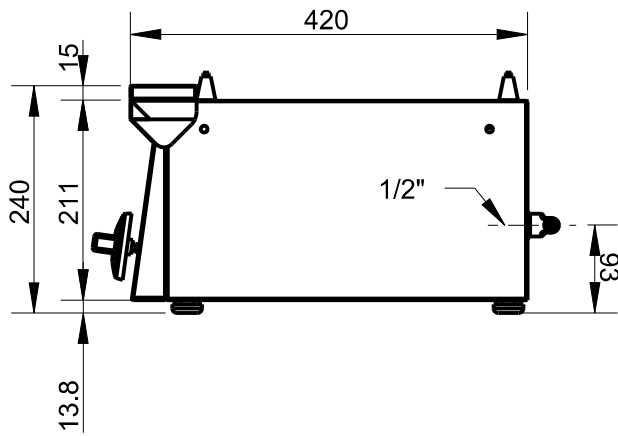

POTENCIA: 7 kW



FAMILIA: BAR 2009

FECHA: 10/11/10

MODELO: 4403M

PESO(Kg): 7.978

DENOMINACION:
PLANCHA 600X450 GAS SIN ENCIMERA

ESCALA:
1/8

MATERIAL:
INOX

CODIGO:
4403M



Applus®
LGA1
Organismo
Notificado
0370

AENOR
Organismo
Notificado
0099



TOLERANCIAS GENERALES: ±0.5 mm

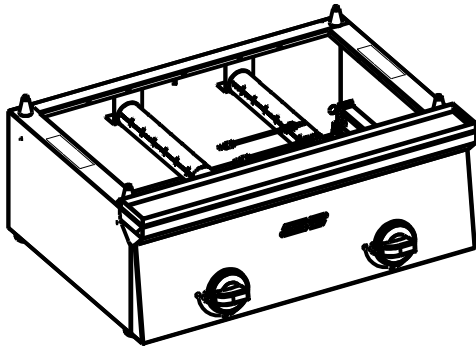

QT	COD	DESCRIPCION
8	1014	REMACHE ROSCADO M-10
1	3057	TETINA 1/2"
1	96107	ESPATULA PLANCHA
1	440294	SOPORTE IZQ. BATERÍA BAR
1	440319	FRONTAL SOBRE PLANCHA 600
1	440349	CANAL PLANCHA 600
1	441226	ENVOLVENTE BAR 600
1	441239	FRONTAL MANDOS BAR 2F.
2	340173PM	CONJUNTO MANDO A GAS
1	440385PC	BATERIA COMP.BAR 600
2	440387M	KIT 1 QUEMADOR PLANCHA BAR
4	440389P	CENTRADOR PLANCHA
2	C5811019	TERMOPAR M8 C/ROSCADA L.320
4	C5811029	TUERCA TERMOPAR M8
2	C5816299M	CONJUNTO GRIFO EJE CORTO
4	C6260549	PATA PA M-10X30 BASE D.30
2	T18030	TUBO AL D.8 AMPL. D.10 L.300

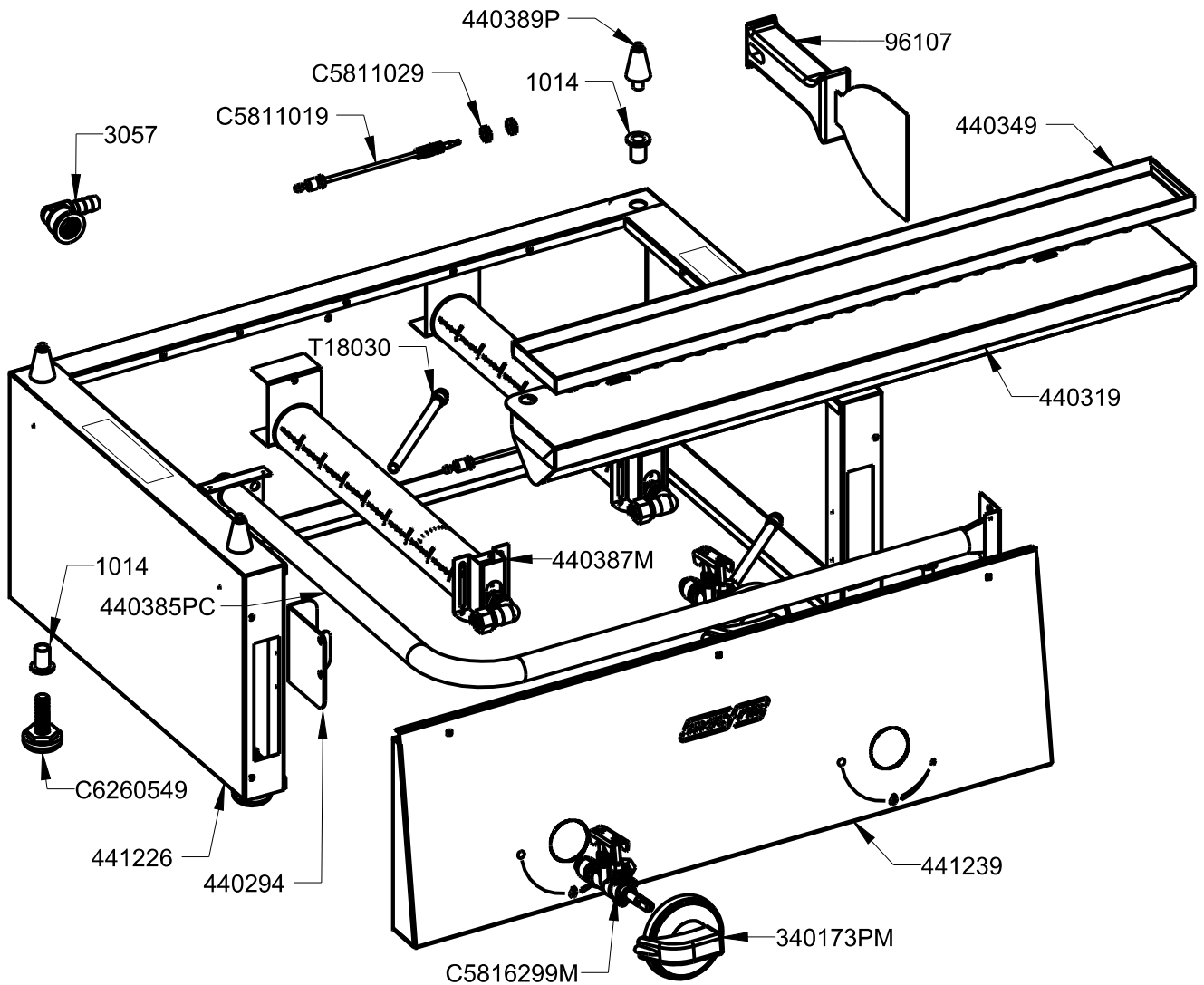

FAMILIA: BAR 2009

FECHA: 10/11/10

MODELO: 4403M

PESO(Kg): 7.978

DENOMINACION:
PLANCHA 600X450 GAS SIN ENCIMERA

ESCALA:
1/5

MATERIAL:
INOX

CODIGO:
4403M



Applus®
LGA1
Organismo
Notificado
0370

AENOR
Organismo
Notificado
0099



TOLERANCIAS GENERALES: ±0.5 mm

QT	COD	DESCRIPCION	FAB.	MATERIAL	DATA	PESO
2	300184	AIREADOR QUEMADOR	SÍ	INOFER 0.8	09/06/09	0.023
2	330294	PLETINA BASE BATERÍA	SÍ	FE 1.5	03/11/08	0.021
1	440294	SOPORTE IZQ. BATERÍA BAR	SÍ	GALVA 1.5	03/03/10	0.068
1	440319	FRONTAL SOBRE PLANCHA 600	SÍ	INOFER 0.8	01/03/10	0.730
1	440349	CANAL PLANCHA 600	SÍ	INOFER 0.8	08/02/10	0.442
2	440394	SOPORTE QUEMADOR PLANCHA	SÍ	GALVA 0.8	23/12/10	0.034
1	441226	ENVOLVENTE BAR 600	SÍ	INOFER 0.8	03/03/10	2.653
1	441239	FRONTAL MANDOS BAR 2F.	SÍ	INOFER 0.8	01/03/10	0.958
2	440387M	KIT 1 QUEMADOR PLANCHA BAR	SÍ	INOX	12/02/10	0.470
8	1014	REMACHE ROSCADO M-10	NO	ZN	17/12/09	0.008
1	3057	TETINA 1/2"	NO	LATON	01/01/01	0.075
2	31691	BRIDA 1/2" SABAF	NO	FE ZN	13/02/09	0.011
1	96107	ESPATULA PLANCHA	NO	INOX	01/01/01	0.402
2	340172P	EMBELLECEDOR MANDO GAS/ELECT.	NO	ABS	10/12/07	0.018
2	340173P	MANDO COCINA GAS 2008	NO	BAQUELITA	10/12/07	0.064
2	340173PM	CONJUNTO MANDO A GAS	NO	BAQUELITA	10/12/07	0.082
1	440385P	BATERIA BAR 600	NO	FE 1/2"	20/04/11	0.446
1	440385PC	BATERIA COMP.BAR 600	NO	FE ZINCADO	20/04/11	0.501
2	440387P	QUEMADOR TUBULAR D.40 L.300	NO	INOX	05/08/09	0.329
4	440389P	CENTRADOR PLANCHA	NO	FE CROMADO	08/02/10	0.037
4	C1061243	TORNILLO M-4X25 DIN933 ZN	NO	FE ZN	12/02/09	0.003
2	C5811019	TERMOPAR M8 C/ROSCADA L.320	NO	CU	09/02/09	0.015
4	C5811029	TUERCA TERMOPAR M8	NO	CU	01/01/08	0.002
2	C5812639	INY. D.085 GLP QUEM. L.300	NO	LATON	04/09/08	0.012
2	C5812659	INY.D.120GLP.L.550/GN.L.300	NO	LATON	04/09/08	0.012
2	C5815159	PORTAINYECTOR COMPLETO	NO	LATON	01/01/09	0.058
2	C5815559	BICONO D.8 SABAF	NO	LATON	13/02/09	0.001
2	C5815569	TUERCA 1/4" D.8 SABAF	NO	FE ZN	13/02/09	0.003
2	C5816299	GRIFO PLANCHA BAR	NO	LATON	09/09/09	0.205
2	C5816299M	CONJUNTO GRIFO EJE CORTO	NO	LATON	09/09/09	0.227
1	C5816309	TOMA DE PRESIÓN PARA BATERIA	NO	LATON	31/03/11	0.013
4	C6260549	PATA PA M-10X30 BASE D.30	NO	PA NEGRA	15/04/10	0.074
2	T18030	TUBO AL D.8 AMPL. D.10 L.300	NO	AL 99.7%	15/04/10	0.027



FAMILIA: BAR 2009

FECHA: 10/11/10

MODELO: 4403M

PESO(Kg): 7.978

DENOMINACION:
PLANCHA 600X450 GAS SIN ENCIMERA

ESCALA:
1/5

MATERIAL:
INOX

CODIGO:
4403M



Applus®
LGA1
Organismo
Notificado
0370

AENOR
Organismo
Notificado
0099



TOLERANCIAS GENERALES: ±0.5 mm

QT	COD	DESCRIPCION
1	300184	AIREADOR QUEMADOR
1	440394	SOPORTE QUEMADOR PLANCHA
1	440387P	QUEMADOR TUBULAR D.40 L.300
1	C5812639	INY. D.085 GLP QUEM. L.300
1	C5812659	INY.D.120GLP.L.550/GN.L.300
1	C5815159	PORTAINYECTOR COMPLETO

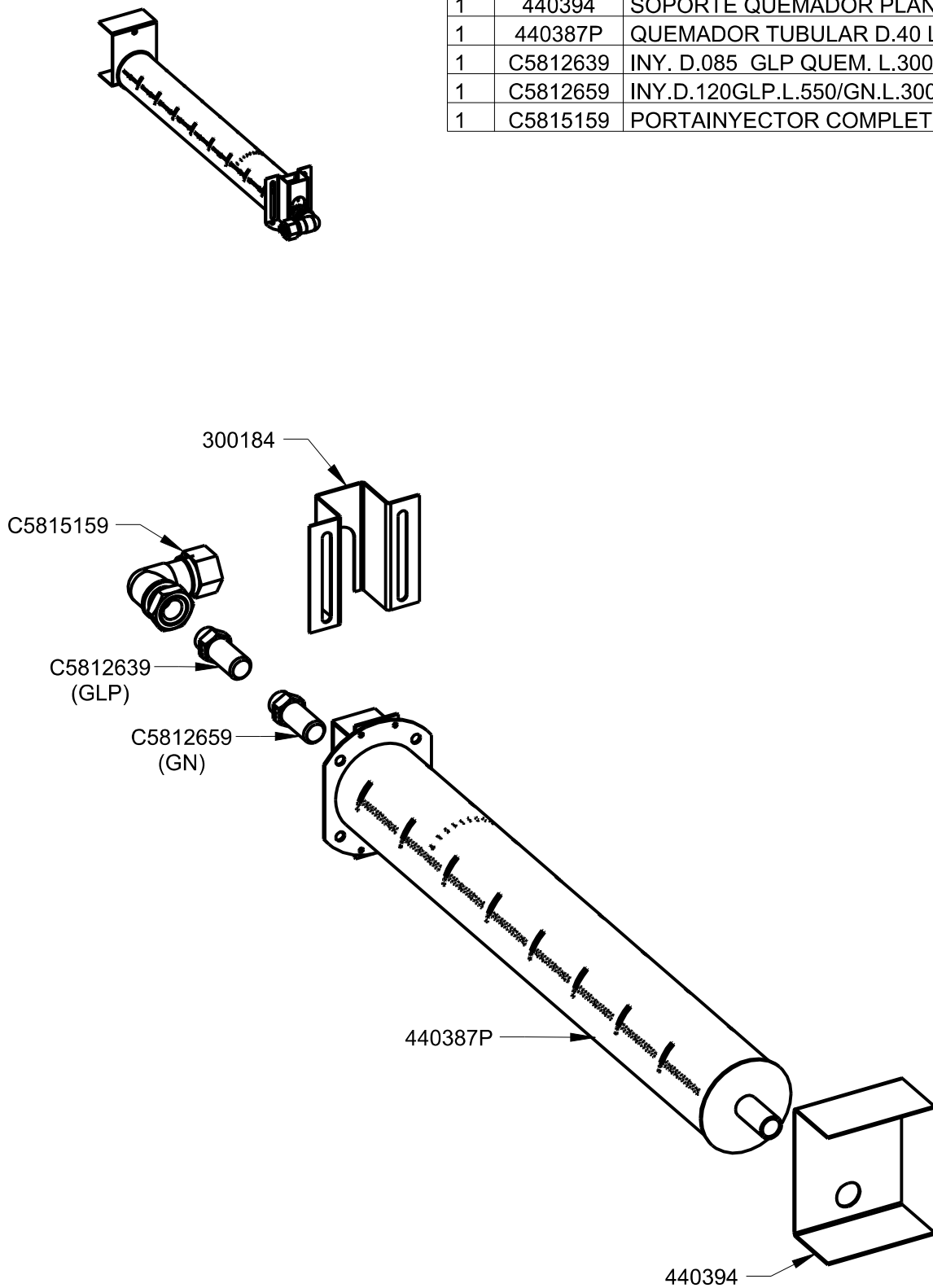

FAMILIA: BAR 2009

FECHA: 12/02/10

MODELO: 4403

PESO(Kg): 0.470

DENOMINACION:
KIT 1 QUEMADOR PLANCHA BAR

ESCALA:
1/4

MATERIAL:
INOX

CODIGO:
440387M



Applus®
LGA1
Organismo
Notificado
0370

AENOR
Organismo
Notificado
0099



TOLERANCIAS GENERALES: ±0.5 mm

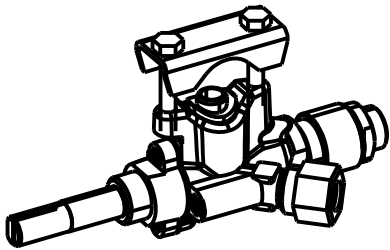

ESCALA 1/2

QT	COD	DESCRIPCION
1	31691	BRIDA 1/2" SABAF
2	C1061243	TORNILLO M-4X25 DIN933 ZN
1	C5815559	BICONO D.8 SABAF
1	C5815569	TUERCA 1/4" D.8 SABAF
1	C5816299	GRIFO PLANCHA BAR

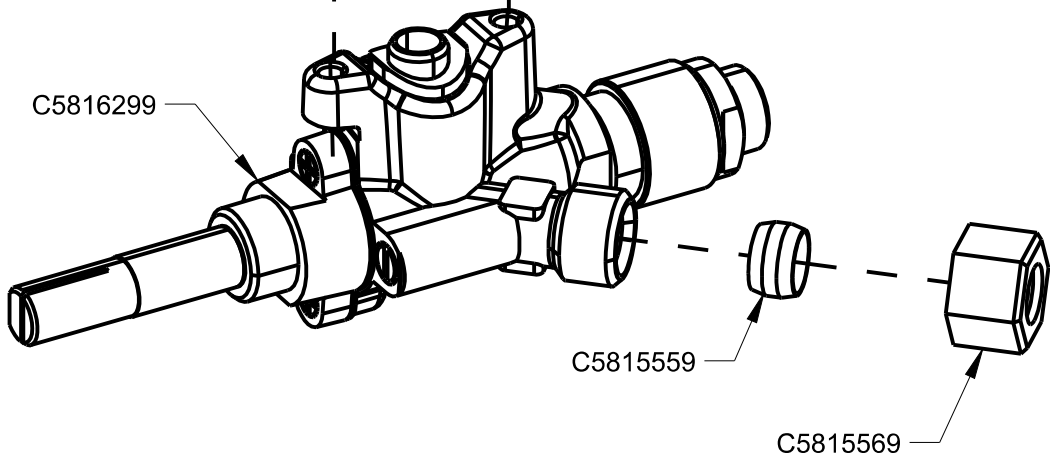
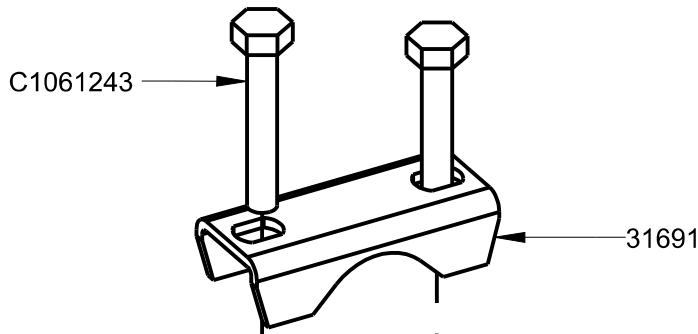
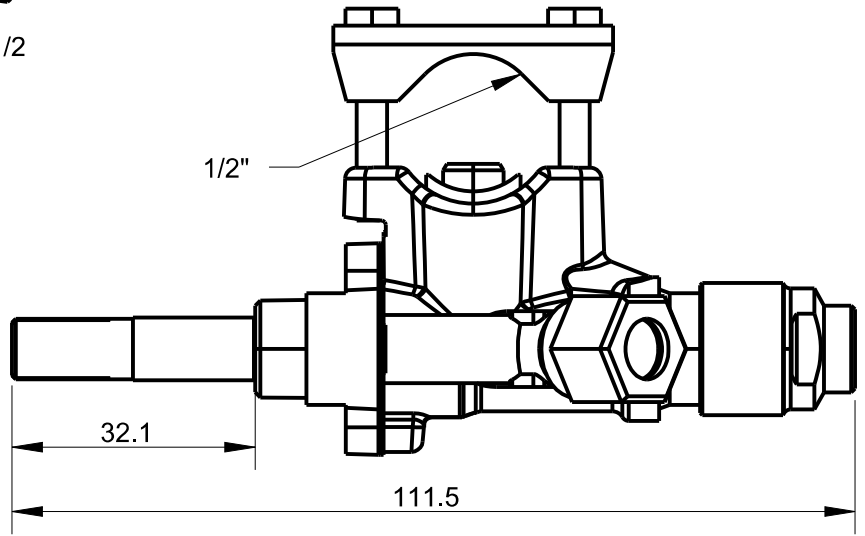

FAMILIA: BAR 2009

FECHA: 09/09/09

MODELO: 4412

PESO(Kg): 0.227

DENOMINACION:
CONJUNTO GRIFO EJE CORTO

ESCALA:
1/1

MATERIAL:
LATON

CODIGO:
C5816299M