

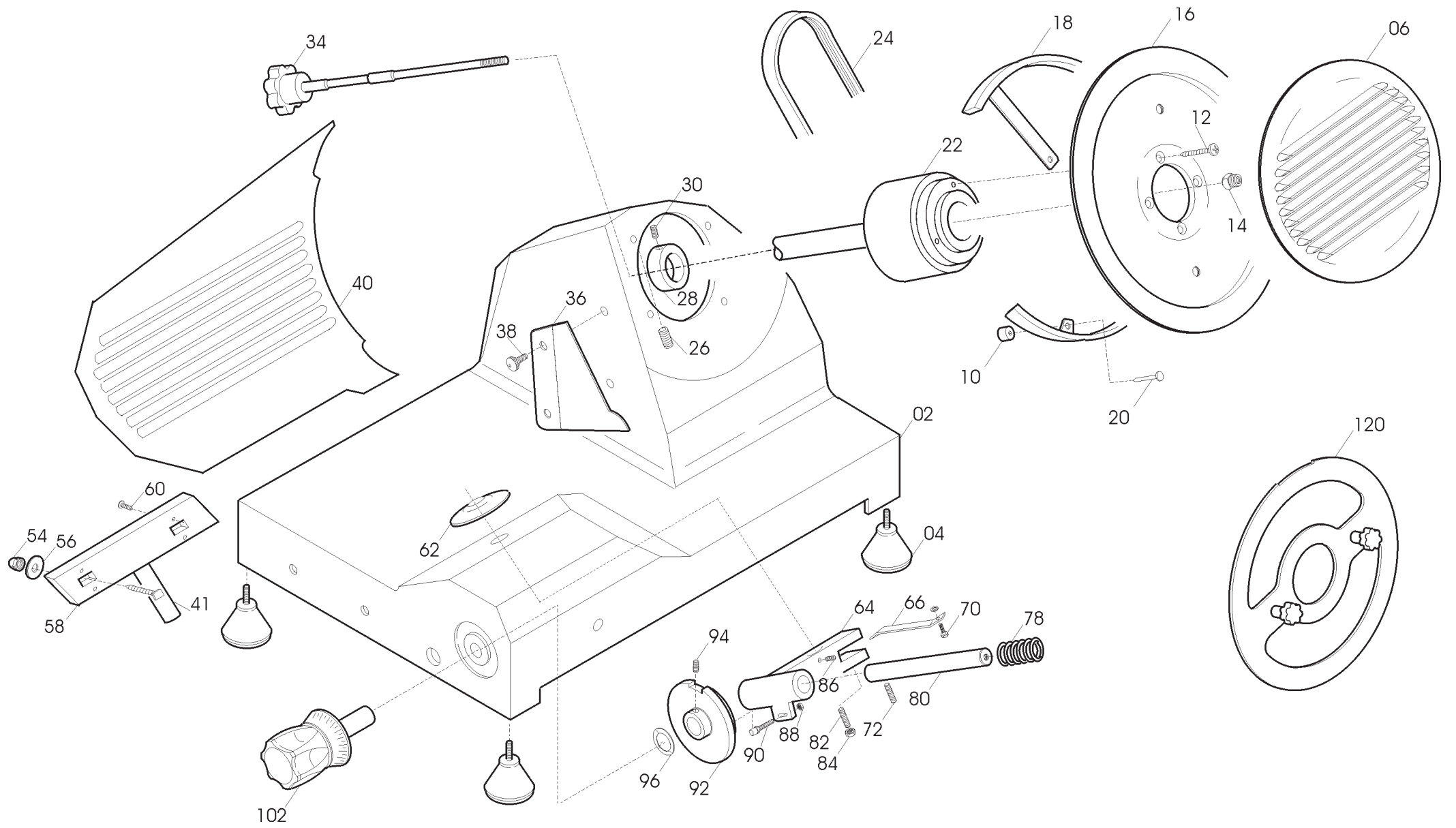

**Vorbereitung
Aufschnittmaschinen**

Artikel-Nr. 411003
(15303002W (Mira 300 CE))

Explosionszeichnung



Name
Zeichnung : *MIRRA 300 CE TAV.*

Ref.	Produktname	Artikel-Nr
02	BASAMENTO MRR 275-300	SM500116
04	PIEDINO PICCOLO DOPPIO M 5	19560201
06	PARALAMA CE MRR 300	SM500503
102A	MANOPOLA NUMER.MRR PERNO D.12MM	19562402
102B	MAN. NUMERATA BLU X MRR	19564020
102C	MANOPOLA NUMERATA GRIGIA X MRR	19564030
120	DISCO ESTRATTORE LAMA PER 300	19702508

14	QUADR.TIR.PARAL. MRR 300 CE/NORM/UL	SM133418
16A	LAMA 300 - 40/3/254 NAZ. F.ESTR.	18300403254F
16B	LAMA 300 - 40/3/254 22.5 TEF.F.EST.	1830040325422TF
18	ANELLO PROT. LAMA MRR 300	SM503403
22	PULEGGIA MONTATA MRR 275-300	SM591519
24	CINGH.PIAT.SG 275 TB2 360 X 8	19310206
28	ANELLO PORTA MICRO MRR	19540901
34A	TIRANTE PARALAMA MRR 275-300	SM212740
34B	TIRANTE PARAL.BLU MRR 275-300	SM212740B
34C	TIRANTE PARAL.GRIG.MRR 275-300	SM212740G
36	PARAFETTA MRR 300	SM501203
38	VITE PARAFETTA TGI 350-390	SM110604
40	VELA ESTRUSA MRR 300 CE	SM504120
41	VITE X VELA TQ 8MA L25 M 300 CE/UL	SM17006004
58	SUPP. VELA MRR 300 CE/NORM/UL	SM500318
62	PARA ACQUA MRR	19563001
64	MOVIMENTO VELA MRR 275-300	SM500218
66	PIASTRINA MOV. MRR 275-300	SM540118
78	MOLLA MOV. VELA MRR 275-300	SM370111
80	PERNO MOVIM. MRR 275-300	SM521218
90	PERNO RULL. MOV. MRR 275-300	SM131918
92	CAMMA MRR 275/300 CE	SM190100011
96	RONDELLA ONDULATA 12	19342005