

# MF 30

## Electronic modular flaker

Spare parts list

Catalogo ricambi

Catalogues pièces détachées

Ersatzteilkatalog

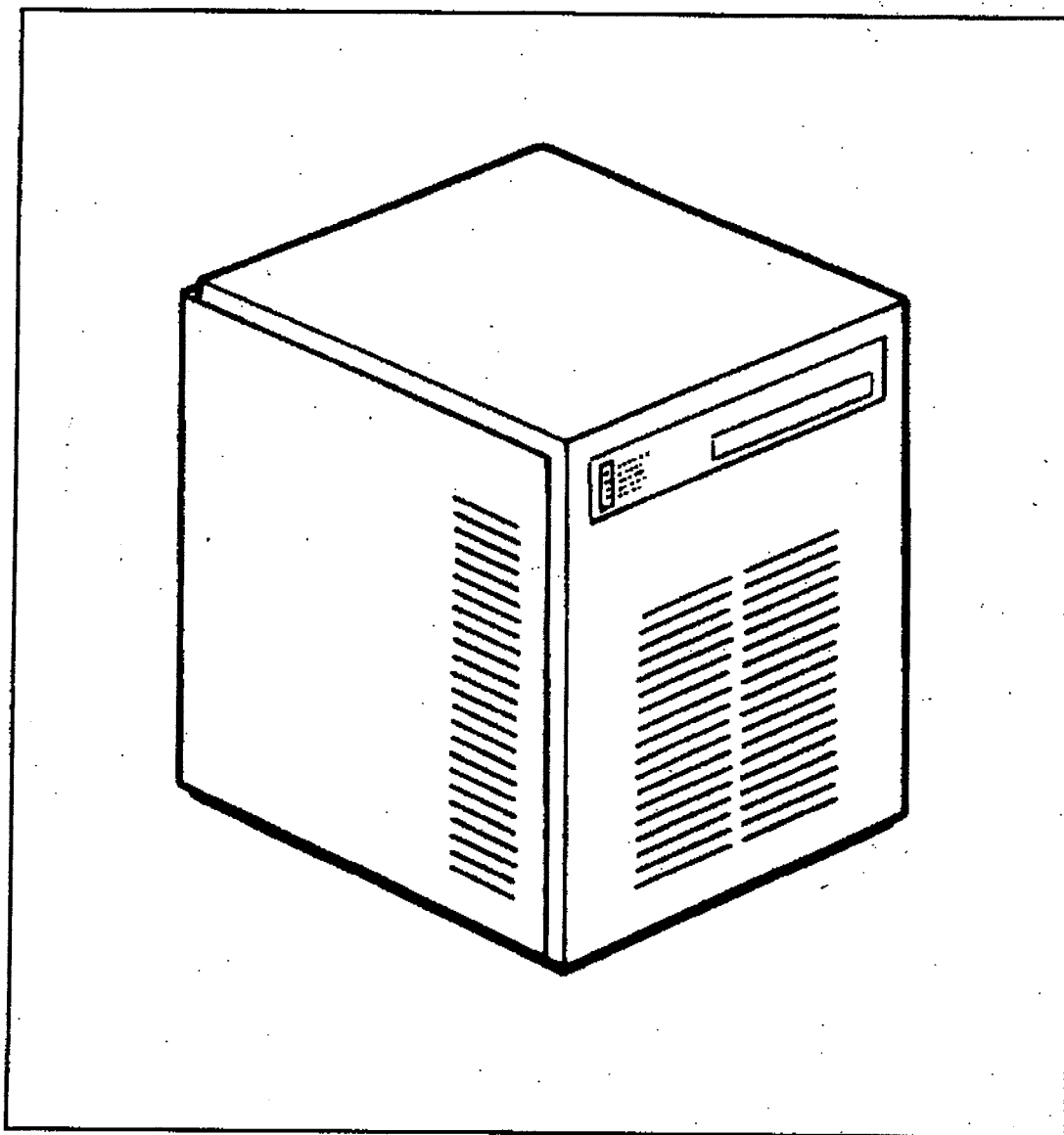

**SCOTSMAN®**

**ICE SYSTEMS**

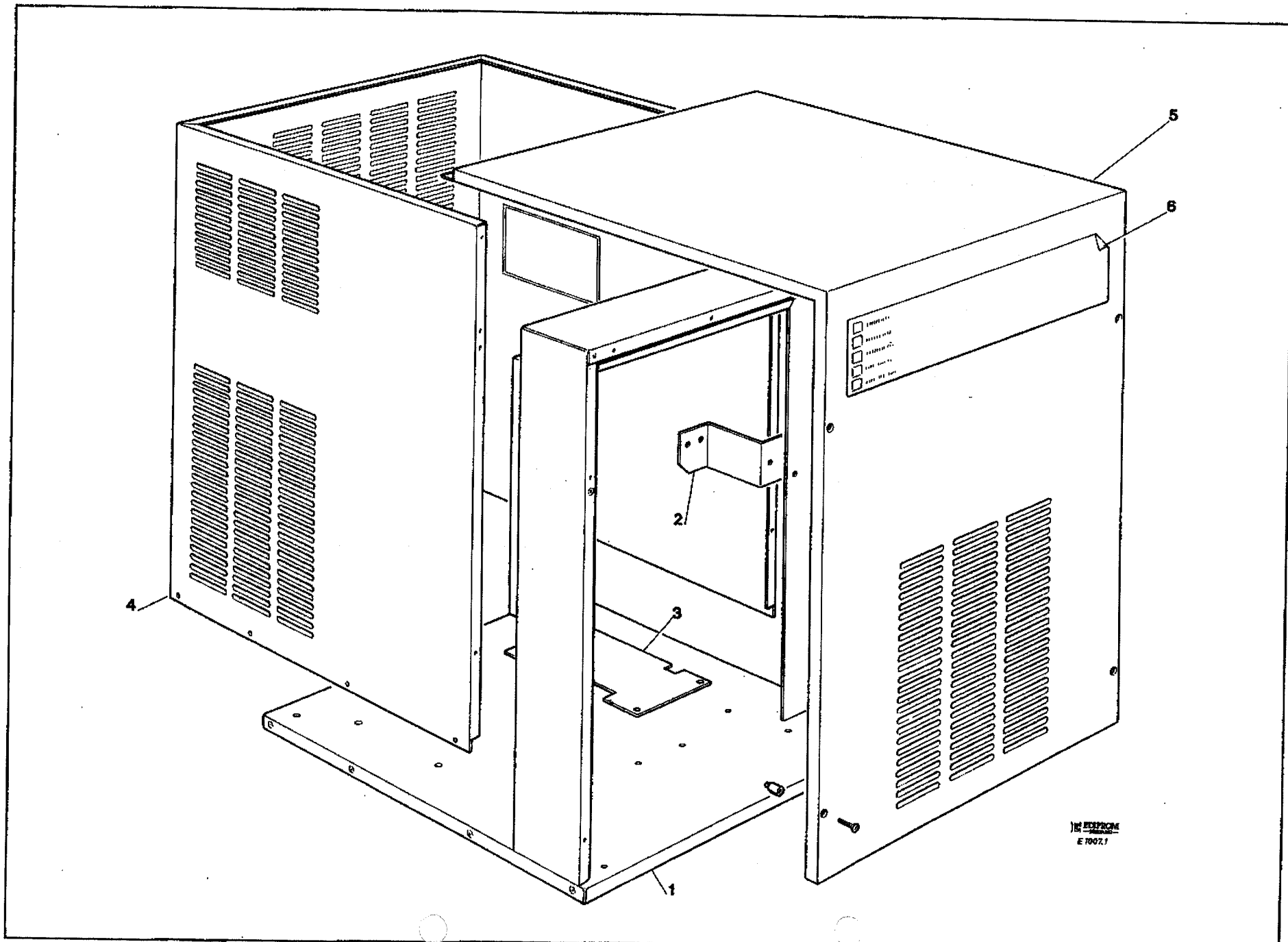

THE ESPRIMO  
E 7007.1

## MF 30 - UNIT PANELS - ASSIEME MOBILE - ENS. CARROSSERIE - MACHINE GEHAUSE

ITEM NO POS NO REP. NO REF. NO	PART NO CODICE REFERENCE STUECK NR	DESCRIPTION	DESCRIZIONE	DESIGNATION	BESCHREIBUNG
1	781399 00	FRAME ASSY S.S.	ASSIEME TELAIO ACCIAIO INOX	ENSAMBLE CHASSIS ACIER INOX	CHASSISRAHMEN EDELSTAHL
2	703221 00	WATER RESERVOIR BRACKET	SUPPORTO VASCH. GALLEGGIANTE	SUPPORT FLOTTEUR	SCHWIMMERHALTER
3	704256 01	GEAR MOTOR BASE	SUPPORTO MOTORIDUTTORE	SUPPORT MOTOREDUCTEUR	GETRIEBEMOTORHALTER
4	721550 00	SIDES/REAR PANEL S.S.	PANNELLO LATERALE/POSTER. ACC. INOX	PANNEAU COTE/ARRIERE ACIER INOX	EDELSTAHL SEITEN-RÜCKWAND
5	722149 00	FRONT/TOP PANEL S.S.	PANNELLO FRONTALE/SUPER. ACC. INOX	PANNEAU AVANT/SUP. ACIER INOX	EDELSTAHL FRONT-OBERWAND
6	650369 00	LABEL	ADESIVO SEGNALETICO	ETIQUETTE	ETIKETT

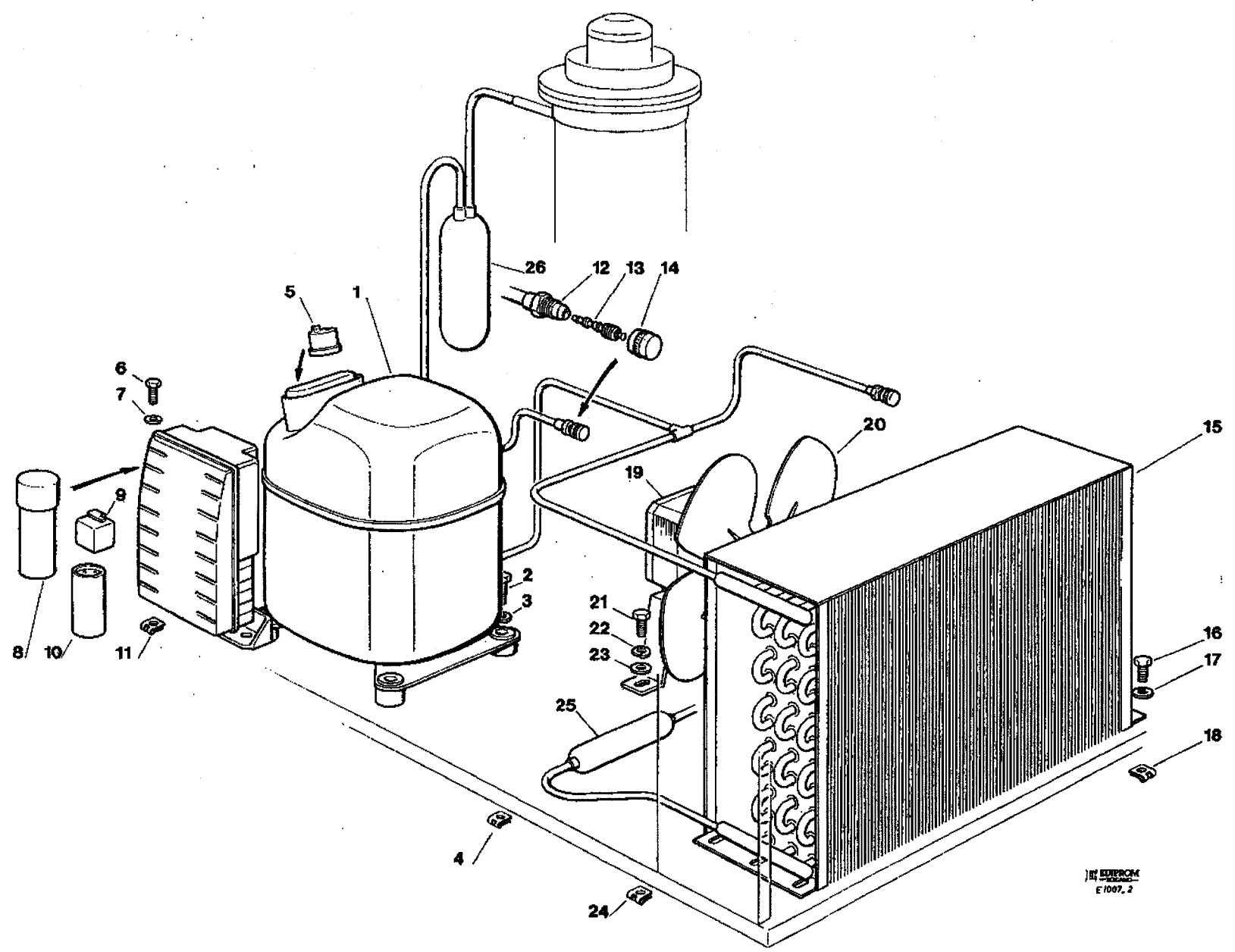

THE EUROPEAN  
E 1007, 2

**MF 30 - REFRIGERANT SYSTEM AIR COOLED - SISTEMA REFRIGERANTE RAFFR. AD ARIA**  
**CIRCUIT FRIGORIFIQUE REFROID. PAR AIR - LUFTGEKÜHLT GEFRIERSYSTEM**

ITEM NO POS NO REP. NO REF. NO	PART NO CODICE REFERENCE STUECK NR	DESCRIPTION	DESCRIZIONE	DESIGNATION	BESCHREIBUNG
1	670097 03	COMPRESSOR ASSY	ASSIEME COMPRESSORE	ENSAMBLE COMPRESSEUR	KOMPRESSOR
2	420043 00	SCREW	VITE	VIS	SCHRAUBE
3	440088 00	WASHER	RONDELLA	RONDELLE	SCHEIBE
4	650407 01	METAL CLIP	DADO IN GABBIA	ECROU	MUTTER
5	620058 59	PROTECTOR	PROTETTORE	PROTECTEUR	SCHUTZGERÄT
6	420000 22	SCREW	VITE	VIS	SCHRAUBE
7	440026 00	WASHER	RONDELLA	RONDELLE	SCHEIBE
8	620167 28	RUN CAPACITOR	CAPACITA DI MARCIA	CAPACITÉ PERMANENCE	BETRIEB KONDENSATOR
9	620168 19	START RELAY	RELE DI AVVIAMENTO	RELAIS DE DEMARRAGE	RELAIS
10	620167 27	START CAPACITOR	CAPACITA D'AVVIAMENTO	CAPACITÉ DE DEMARRAGE	START KONDENSATOR
11	650029 03	METAL CLIP	DADO IN GABBIA	ECROU	MUTTER
12	650109 00	VALVE BODY	CORPO VALVOLA	CORPS DE VANNE	VENTILGEHAUSE
13	670012 00	VALVE PISTON	PISTONCINO VALVOLA	PISTON	VENTILKOLBEN
14	650106 00	VALVE CAP	CAPPUCCIO VALVOLA	CAPUCHON DE VANNE	VENTILKLAPPE
15	620405 00	AIR COOLED CONDENSER	CONDENSATORE AD ARIA	CONDENSEUR A AIR	LUFTGEKUEHLT KONDENSATOR
16	420000 23	SCREW	VITE	VIS	SCHRAUBE
17	440084 00	WASHER	RONDELLA	RONDELLE	SCHEIBE
18	650029 03	METAL CLIP	DADO IN GABBIA	ECROU	MUTTER
19	620003 22	FAN MOTOR	MOTORE VENTILATORE	MOTEUR VENTILATEUR	LUFTER MOTOR
20	620007 07	FAN BLADE	VENTOLA	HELICE	FLUEGEL
21	420010 00	SCREW	VITE	VIS	SCHRAUBE
22	440084 00	WASHER	RONDELLA	RONDELLE	SCHEIBE
23	440026 00	LOCK WASHER	RONDELLA SPACCATA	RONDELLE	SCHEIBE
24	650029 03	METAL CLIP	DADO IN GABBIA	ECROU	MUTTER
25	630003 03	DRIER	FILTRO DEUMIFICATORE	FILTRE DESHYDRATEUR	TROCKNER
26	784406 05	SUCTION LINE/ACCUMULATOR	ACCUMUL. E LINEA ASPIRAZIONE	ENS. ASPIRATION/ACCUMULATEUR	SAMMLER UND SAUGLEITUNGEN

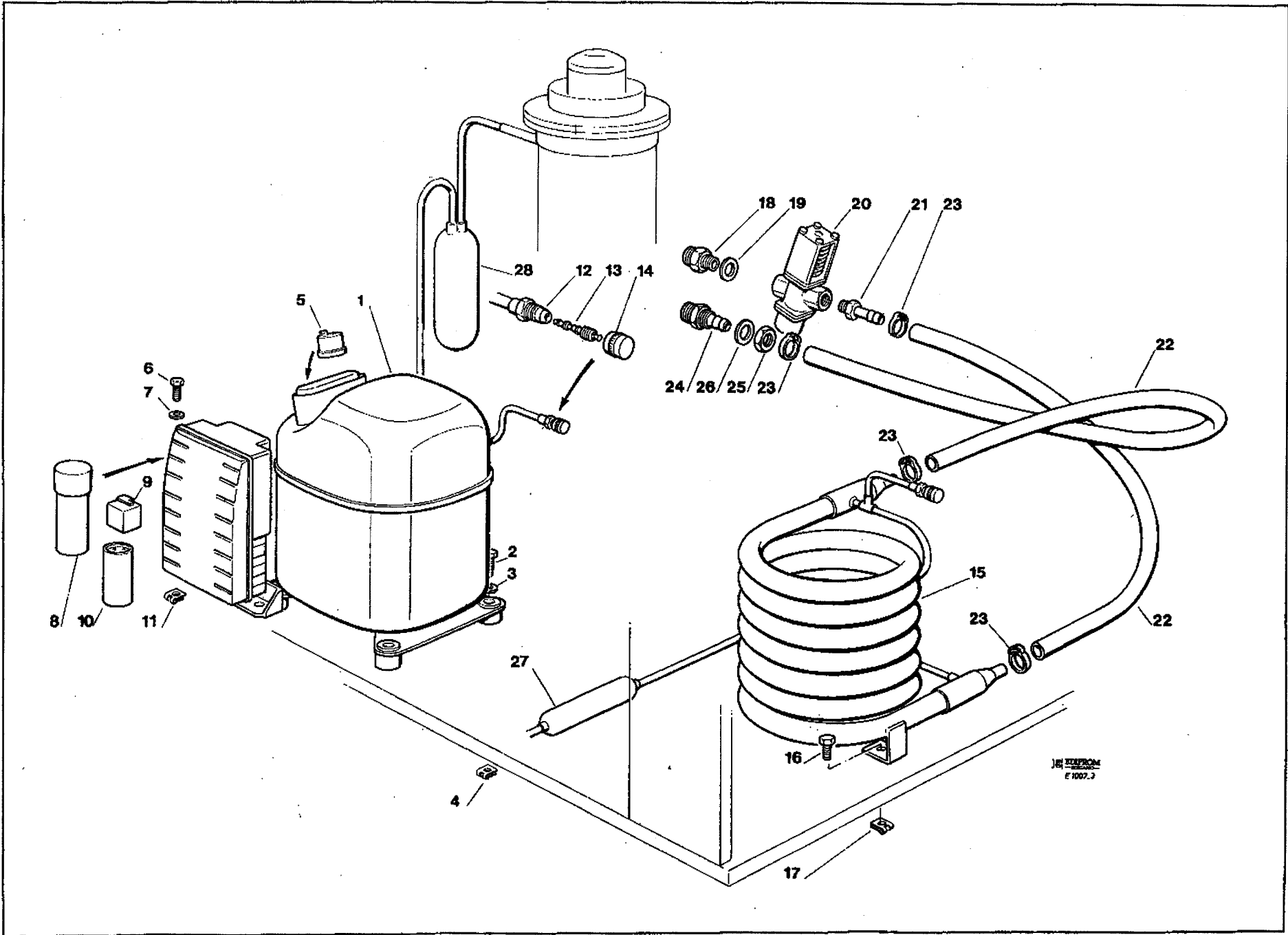

**MF 30 - REFRIGERANT SYSTEM WATER COOLED - SISTEMA REFRIGERANTE RAFFR. AD ACQUA**  
**CIRCUIT FRIGORIFIQUE REFROID. PAR EAU - WASSERGEKÜHLT GEFRIERSYSTEM**

ITEM NO POS NO REP. NO REF. NO	PART NO CODICE REFERENCE STUECK NR	DESCRIPTION	DESCRIZIONE	DESIGNATION	BESCHREIBUNG
1	670097 03	COMPRESSOR ASSY	ASSIEME COMPRESSORE	ENSAMBLE COMPRESSEUR	KOMPRESSOR
2	420043 00	SCREW	VITE	VIS	SCHRAUBE
3	440088 00	WASHER	RONDELLA	RONDELLE	SCHEIBE
4	650407 01	METAL CLIP	DADO IN GABBIA	ECROU	MUTTER
5	620058 59	PROTECTOR	PROTETTORE	PROTECTEUR	SCHUTZGERÄT
6	420000 22	SCREW	VITE	VIS	SCHRAUBE
7	440026 00	WASHER	RONDELLA	RONDELLE	SCHEIBE
8	620167 28	RUN CAPACITOR	CAPACITA DI MARCIA	CAPACITÉ PERMANENCE	BETRIEB KONDENSATOR
9	620188 19	START RELAY	RELE DI AVVIAMENTO	RELAIS DE DEMARRAGE	RELAIS
10	620167 27	START CAPACITOR	CAPACITA D'AVVIAMENTO	CAPACITÉ DE DEMARRAGE	START KONDENSATOR
11	650029 03	METAL CLIP	DADO IN GABBIA	ECROU	MUTTER
12	650109 00	VALVE BODY	CORPO VALVOLA	CORPS DE VANNE	VENTILGEHAUSE
13	670012 00	VALVE PISTON	PISTONCINO VALVOLA	PISTON	VENTILKOLBEN
14	650106 00	VALVE CAP	CAPPUCCIO VALVOLA	CAPUCHON DE VANNE	VENTILKLAPPE
15	620331 03	WATER COOLED CONDENSER	CONDENSATORE AD ACQUA	CONDENSEUR A EAU	WASSERGEKUEHLT KONDENSATOR
16	420010 00	SCREW	VITE	VIS	SCHRAUBE
17	650029 03	METAL CLIP	DADO IN GABBIA	ECROU	MUTTER
18	733204 00	WATER INLET FITTING	RACCORDO INGRESSO ACQUA	RACCORD ARRIVÉE D'EAU	WASSEREINLAUFSTÜCK
19	400031 01	FIBER WASHER	RONDELLA IN FIBRA	RONDELLE EN FIBRE	FIBER SCHEIBE
20	620111 00	WATER REGULATING VALVE	VALVOLA PRESSOSTATICA	VANNE A EAU PRESSOSTATIQUE	WASSERREGLERVENTIL
21	733173 00	OUTLET VALVE FITTING	RACCORDO USCITA VALVOLA PRESS.	RACCORD SORTIE VALVE PRESS.	WASSERREGLEREABFLUSSSTUECK
22	281900 03	PLASTIC TUBE-PER METER	TUBO IN PLASTICA-PER METRO	TUYAU EN PLASTIQUE-POUR METRE	PLASTIK ROHR-PRO METER
23	650499 00	PLASTIC CLAMP	FASCETTA IN PLASTICA	COLLIER EN PLASTIQUE	PLASTIK SCHELLE
24	733174 00	WATER DRAIN FITTING	RACCORDO SCARICO ACQUA	RACCORD ÉVACUATION EAU	WASSERABFLUSSSCHLAUCH
25	400076 00	NUT	DADO	ECROU	MUTTER
26	400031 00	FIBER WASHER	RONDELLA IN FIBRA	RONDELLE EN FIBRE	FIBER SCHEIBE
27	670003 03	DRIER	FILTRO DEUMIDIFICATORE	FILTRE DESHYDRATEUR	TROCKNER
28	784406 05	SUCTION LINE/ACCUMULATOR	ACCUMUL. E LINEA ASPIRAZIONE	ENS. ASPIRATION/ACCUMULATEUR	SAMMLER LEITUNGEN

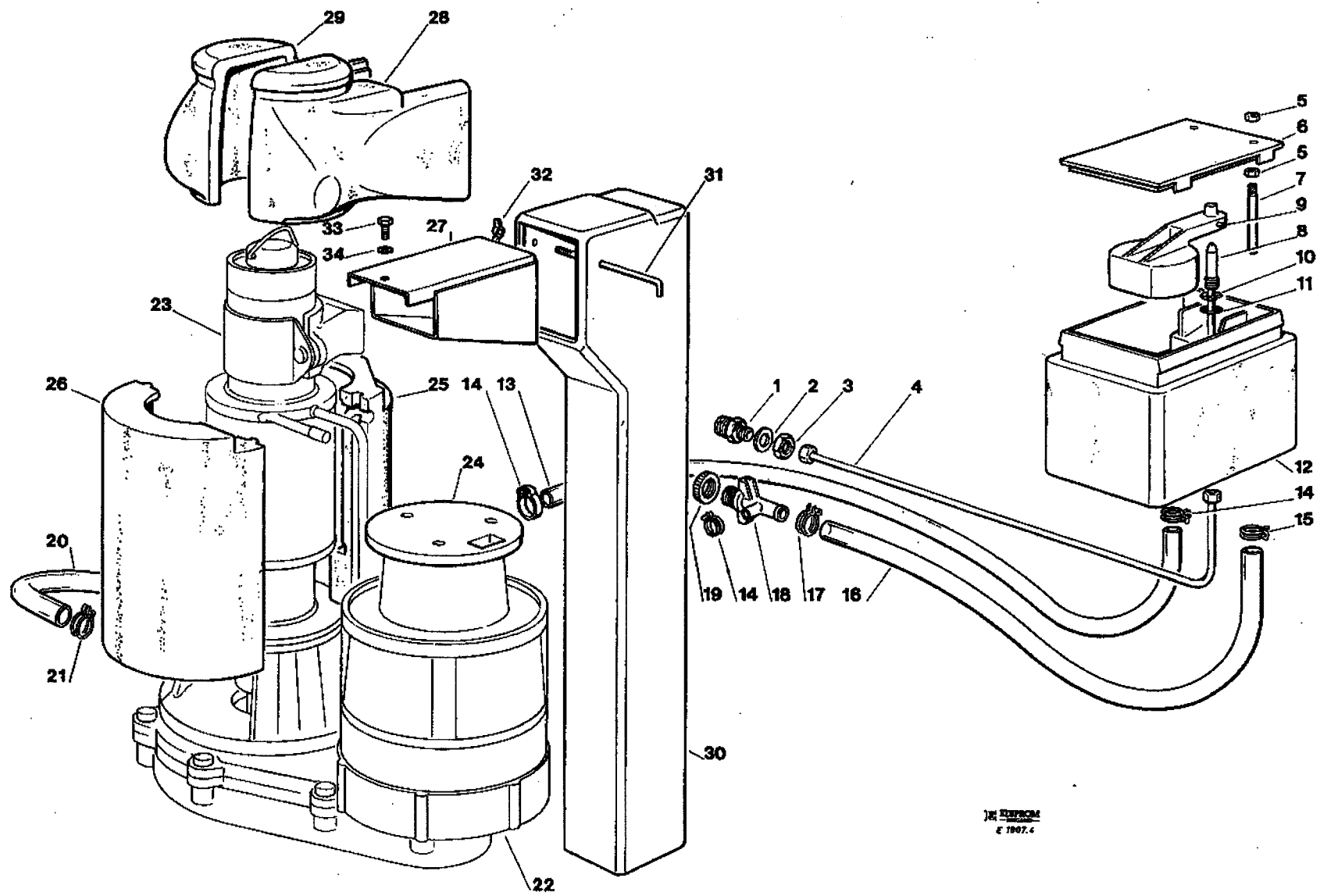

DE HOFFMANN  
E 1807.6



**MF 30 - WATER SYSTEM AND INSULATIONS - CIRCUITO IDRAULICO ED ISOLAMENTI**  
**CIRCUIT HYDRAULIQUE ET ISOLATIONS - WASSERKREISLAUF UND ISOLIERUNGEN**

ITEM NO POS NO REP. NO REF. NO	PART NO CODICE REFERENCE STUECK NR	DESCRIPTION	DESCRIZIONE	DESIGNATION	BESCHREIBUNG
1	733205 00	WATER INLET FITTING	RACCORDO INGRESSO ACQUA	RACCORD ARRIVEE D'EAU	WASSEREINLAUFSTUECK
2	400031 00	FIBER WASHER	RONDELLA IN FIBRA	RONDELLE EN FIBRE	FIBER SCHEIBE
3	400030 01	NUT	DADO	ECROU	MUTTER
4	NO NUMBER	COPPER TUBE	TUBO DI RAME	TUYAU EN CUIVRE	KUPFERRHOR
5	430031 00	NUT	DADO	ECROU	MUTTER
6	660363 00	WATER RESERVOIR COVER	COPERCHIO VACHETTA	COUVERCLE	BECKENABDECKUNG
7	724215 06	WATER LEVEL METAL PIN	PERNO SENSORE LIVELLO ACQUA	DETECTEUR NIVEAU EAU	FÜHLERSTIFT-WASSERNIVEAU
8	783153 00	NOZZLE	UGELLO	GICLEUR	VENTILSDUESE
9	783127 00	FLOAT VALVE ASSY	ASS. GALLEGGIANTE	ENS. VANNE A FLOTTEUR	SCHWIMMERVERTIL-EINHEIT
10	460038 02	CLIP RING	ANELLO SEEGER	CIRCLIP	RING
11	640100 00	O RING	GUARNIZIONE OR	JOINT TORIQUE	SIMMERING
12	793126 01	WATER RESERVOIR ASSY	ASS. VASCHETTA GALLEGGIANTE	ENS. RÉSERVOIR	BECKEN/SCHWIMMERVERTILEINHEIT
13	281222 00	PLASTIC TUBE - PER MTR	TUBO IN PLASTICA - PER METRO	TUYAU EN PLASTIQUE - POUR METRE	PLASTIK ROHR - PRO METER
14	650499 00	CLAMP	FASCETTA	COLLIER	SHELLE
15	460022 00	PLASTIC CLAMP	FASCETTA IN PLASTICA	COLLIER EN PLASTIQUE	PLASTIK SHELLE
16	281832 00	PLASTIC TUBE - PER MTR	TUBO IN PLASTICA - PER METRO	TUYAU EN PLASTIQUE - POUR METRE	PLASTIK ROHR - PRO METER
17	460036 00	CLAMP	FASCETTA	COLLIER	SHELLE
18	660224 00	WATER DRAIN FITTING	RACCORDO SCARICO ACQUA	RACCORD EVACUATION EAU	WASSERABFLUSSANSCHLUSSE
19	660535 00	PLASTIC RING NUT	GHIERA IN PLASTICA	COLLIER DE SERRAGE EN PLASTIQUE	PLASTIKRINGMUTTER
20	610163 02	PLASTIC TUBE	TUBO IN PLASTICA	TUYAU EN PLASTIQUE	PLASTIK ROHR
21	460025 00	CLAMP	FASCETTA	COLLIER	SHELLE
22	794225 13	GEAR REDUCER ASSY	ASS. MOTORIDUTTORE	ENS. MOTOREDUCTEUR	GETRIEBEMOTOR-EINHEIT
23	794237 01	FREEZER ASSY	ASS. FREEZER	ENS. FREEZER	GEFRIERZYLINDEREINHEIT
24	650515 02	GEAR MOTOR PLASTIC COVER	PROTEZIONE MOTORE	PROTECTION MOTEUR	PLASTIK MOTORSCHUTZ
25	660376 00	INSULATION LEFT	ISOLAMENTO SINISTRO	ISOLATION GAUCHE	GEFRIERZYLINDERISOLIERUNG-LINKS
26	660376 01	INSULATIONRIGHT	ISOLAMENTO DESTRO	ISOLATION DROITE	GEFRIERZYLINDERISOLIERUNG-RECHTS
27	784053 03	S.S. ICE SPOUT	BOCCHETTA SCARICO GHIACCIO	BEC VERSEUR	AUSWURFSCHNAUZE
28	660133 00	SPOUT INSULATION LEFT	ISOLAMENTO BOCC. SINISTRO	ISOLATION GAUCHE BEC VERSEUR	AUSWURFSCHNAUZEISOLIERUNG
29	660132 00	SPOUT INSULATION RIGHT	ISOLAMENTO BOCC. DESTRO	ISOLATION DROITE BEC VERSEUR	AUSWURFSCHNAUZEISOLIERUNG
30	660455 12	PLASTIC ICE CHUTE	CONDOTTO SCARICO GHIACCIO	GOULOTTE	EIS BUNKERAUSLAUF
31	724180 00	METAL ROD	TIRANTE	TIRANT	STANGE
32	430083 00	WING NUT	DADO AD ALETTE	ECROU	MUTTER

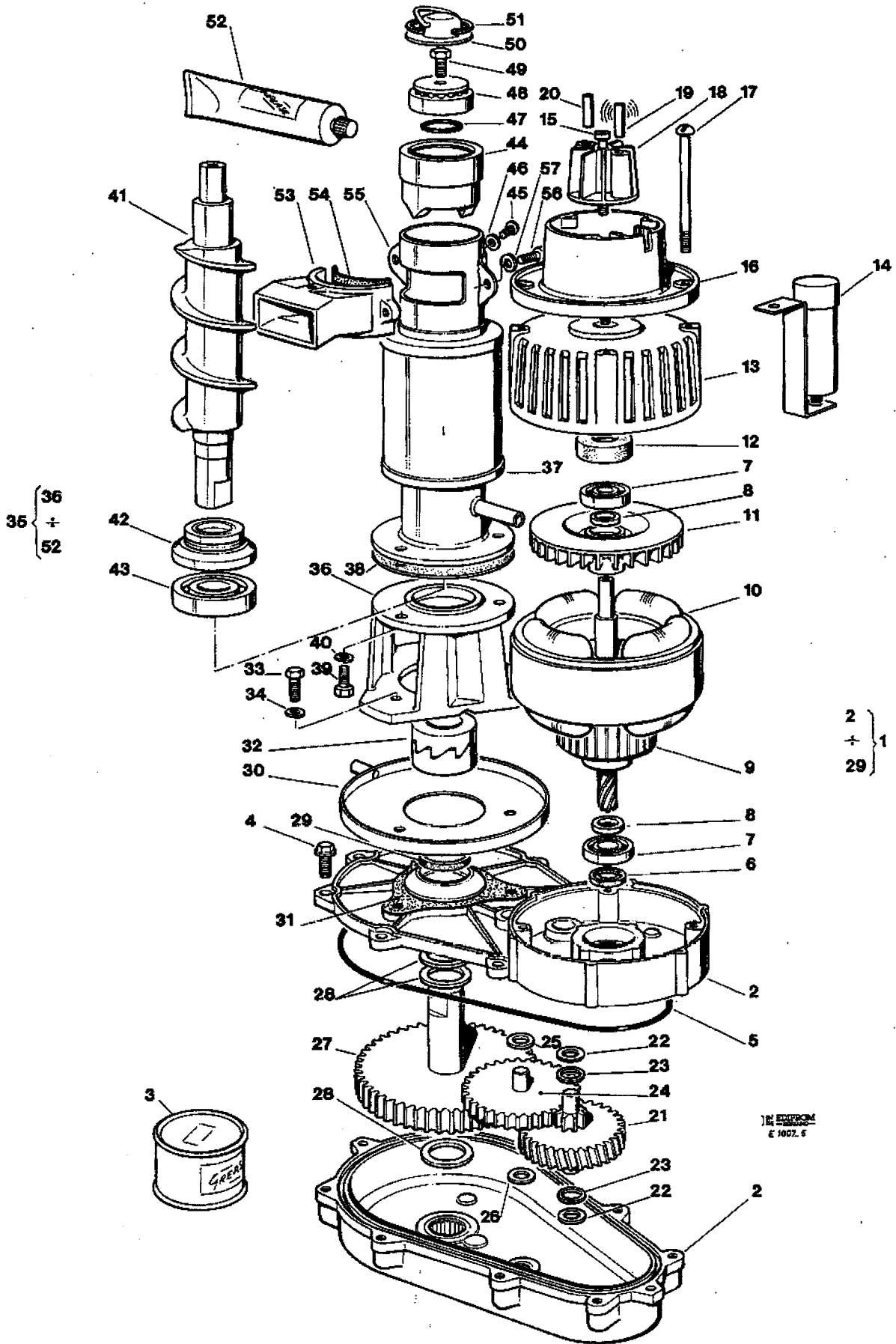

**MF 30 - FREEZER AND GEAR REDUCER ASSY - ASSIEME FREEZER E RIDUTTORE  
ENS. FREEZER ET MOTOREDUCTEUR - GEFRIERZYLINDER UND GETRIEBEEINHEIT**

ITEM NO POS NO REP. NO REF. NO	PART NO CODICE REFERENCE STUECK NR	DESCRIPTION	DESCRIZIONE	DESIGNATION	BESCHREIBUNG
1	794225 13 R	GEAR REDUCER ASSY	ASS. RIDUTTORE	ENS. MOTOREDUCTEUR	GETRIEBEMOTOR CPL
2	001015 01	GEAR CASE ASSY	ASS. SCATOLA INGRANAGGI	ENS. CARTER REDUCTEUR	GETRIEBEGEHAUSE CPL
3	060294 01	GREASE (1 KG)	GRASSO (1 KG)	GRAISSE (1 KG)	FETT (1 KG)
4	03 1251 01	SCREW	VITE	VIS	SCHRAUBE
5	02 1505 00	O RING	GUARNIZIONE OR	JOINT TORIQUE	O RING
6	02 1504 00	GEASE SEAL	PARAOLIO	PARAHUILE	SCHMIERDICHTUNG
7	651056 00	BEARING	CUSCINETTO	ROULEMENT	LAGER
8	441800 09	TRUST WASHER	RONDELLA DI RASAMENTO	RONDELLE	UNTERLEG SCHEIBE
9	794123 03 R	ROTOR ASSY	ASS. ROTORE	ENS. ROTOR	ROTOR EINHEIT
10	620394 00	STATOR ASSY	ASS. STATORE	ENS. STATOR	STATOREINHEIT
11	764001 00	FAN BLADE	VENTOLA	HELICE	FLÜGEL/RAD
12	640095 00	RUBBER INSERT	INSERTO IN GOMMA	BAGUE CAOUTCHOUC	GUMMI LAGER GEHAUSE
13	794226 01	DRIVE MOTOR COVER	COPERCHIO MOTORE	COUVERCLE MOTEUR	MOTOR DEKEL
14	620292 04	CAPACITOR	CONDENSATORE	CONDENSATEUR	KONDENSATOR
15	03 1403 77	SCREW	VITE	VIS	SCHAUBE
16	650515 01	PLASTIC HOUSING	ALLOGGIAMENTO IN PLASTICA	BÂTE DETECTEUR EFF. HALL	KUNSTSTOFFGEHAUSE
17	423872 01	SCREW	VITE	VIS	SCHRAUBE
18	650515 03	MAGNETO HOLDER	SUPPORTO MAGNETE	SUPPORT DU MAGNETO	MAGNETHALTER
19	650515 05	MAGNETIC CYLINDER	CILINDRETTO MAGNETICO	CYLINDRE MAGNETIQUE	MAGNETZYLINDER
20	650515 06	NON MAGNETIC CYLINDER	CILINDRETTO NON MAGNETICO	CYLINDRE NON MAGNETIQUE	NICHT MAGNETISCHES ZYLINDER
21	651180 00	1SR GEAR & PINION	INGRANAGGIO IN FIBRA	ENGRANAGE EN CELERON	1 GETRIEBERAND & RITZEL
22	03 1408 41	TRUST WASHER	RONDELLA DI RASAMENTO	RONDELLE	UNTERLEG SCHEIBE
23	03 1408 38	TRUST WASHER	RONDELLA DI RASAMENTO	RONDELLE	UNTERLEG SCHEIBE
24	651161 00	2ND GEAR & PINION	INGRANAGGIO INTERMEDIO	2eme ENGRANAGE ET PIGNON	2 GETRIEBERAND & RITZEL
25	03 1408 40	TRUST WASHER	RONDELLA DI RASAMENTO	RONDELLE	UNTERLEG SCHEIBE
26	03 1408 39	TRUST WASHER	RONDELLA DI RASAMENTO	RONDELLE	UNTERLEG SCHEIBE
27	651162 01	OUTPUT GEAR & SHAFT	INGRANAGGIO FINALE	PIGNON-ENGR. D'ENTRAINEMENT	GETRIEBERAD & AUSGANGSTIFT
28	03 1408 21	TRUST WASHER	RONDELLA DI RASAMENTO	RONDELLE	SCHEIBE
29	640019 01	GREASE SEAL	PARAOLIO	PARAHUILE	SCHMIERDICHTUNG
30	784062 00	DRIP TRAY	RACCOGLIGOCCE	GOUPELLE EAU	TROPFFPANNE
31	640060 00	GASKET	GURNIZIONE	JOINT	DICHTUNG
32	060359 00	COUPLING	GIUNTO	BAGUE D'ACCOUPEMENT CPL	KUPPLUNG
33	421062 00	SCREW	VITE	VIS	SCHAUBE
34	440015 04	WASHER	RONDELLA	RONDELLE	SCHEIBE
35	794237 01 R	FREEZER ASSY	ASS. FREEZER	ENS. FREEZER	GEFRIERZYLINDEREINHEIT
36	764010 00	ALUMINIUM ADAPTER	SUPPORTO DI ALLUMINIO	SUPPORT	PASSTUECK
37	784261 07	WORM TUBE ONLY	TUBO EVAPORATORE	CYLINDRE EVAPORATEUR	GEFRIERZYLINDER
39	03 1405 38	SCREW	VITE	VIS	SCHRAUBE
40	440015 04	WASHER	RONDELLA	RONDELLE	SCHEIBE
41	724052 06	AUGER	COCLEA	VIS SANS FIN	SCHNECKE
42	640040 00	WATER SEAL	ASSIEME PREMISTOPPA	GARNITURE D'ETANCHEITE	WASSERDICHTUNGENHEIT
43	670011 01	LO BEARING	CUSCINETTO INFERIORE	PALIER INFERIEUR	UNTERESLAGER
44	754001 01	ICE BREAKER ONLY	ROMPIGHIACCIO	BROYEUR	EISBRECHER
45	420000 26	SCREW	VITE	VIS	SCHRAUBE
46	440015 05	WASHER	RONDELLA	RONDELLE	SCHEIBE
47	640041 01	O RING	GUARNIZIONE OR	JOINT TORIQUE	O RING
48	670041 00	TOP BEARING	CUSCINETTO SUPERIORE	PALIER SUPERIEUR	OBERESLAGER
49	420030 00	SCREW	VITE	VIS	SCHAUBE
50	A 07701 00	CAP	CALOTTA	CALOTTE	KUGELHAUBE
51	650297 00	CLIP RING	ANELLO SEEGER	CIRCLIP	RING
52	263612 00	WATER PROOF GREASE	GRASSO IDROREPELL	GRAISSE	FETT
53	754004 00	SPOUT CASTING	BOCCHETTA IN OTTONE	GOULOTTE EN LAITON	MESSINGEISWURFSCHUTE
54	13 0679 00	GASKET	GUARNIZIONE	JOINT	DICHTUNG
55	724087 00	SPOUT PLATE	PIASTRINA BOCCHETTA	BRIDE DE GOULOTTE	EISWURFSCHUTE PLATTE
56	420002 05	SCREW	VITE	VIS	SCHAUBE
57	440015 05	WASHER	RONDELLA	RONDELLE	SCHEIBE

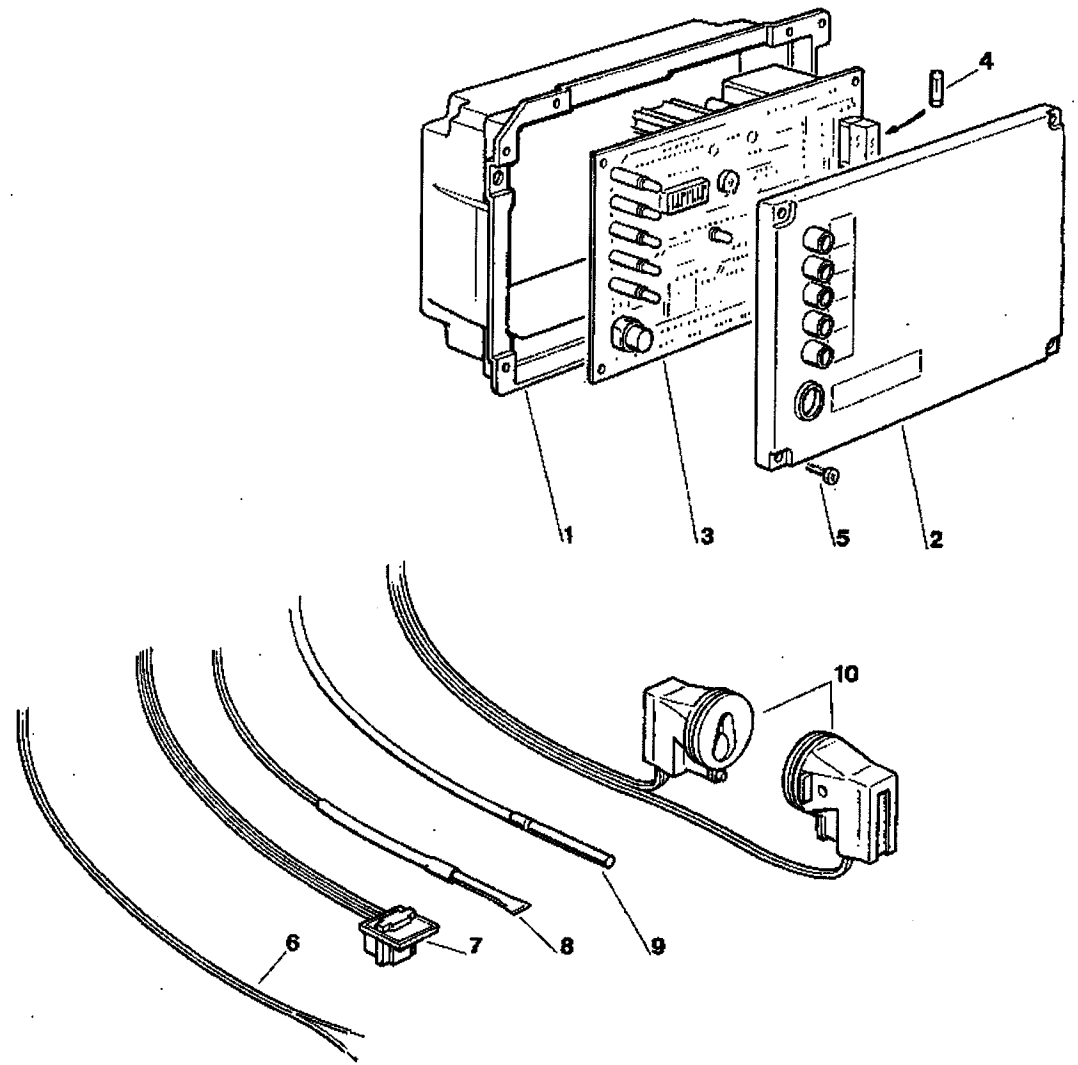

EDIPROM  
E 902.8

**MF 30 - P.C. BOARD AND SENSOR ASSY - SCHEDA ELETTRONICA E SENSORI - ENS. CARTE ELECTRIQUE ET DETECTEURS  
ELEKTRONISCHE KARTE UND TEMPERATURFUEHLERENHEIT**

ITEM NO POS NO REP. NO REF. NO	PART NO CODICE REFERENCE STUECK NR	DESCRIPTION	DESCRIZIONE	DESIGNATION	BESCHREIBUNG
1	660546 00	CONTROL BOX	SCATOLA ELETTRICA	BOITE ELECTRIQUE	SCHALTSCHRANK
2	660547 00	CONTROL BOX COVER	COPERCHIO SCATOLA ELETTRICA	COUVERCLE BOITE DE COMMANDE	SCHALTSCHRANK DECKEL
3	620403 03	P.C. BOARD ASSY	ASSIEME SCHEDA ELETTRONICA	ENSAMBLE CARTE ELECTRONIQUE	GEDRUCKTESCHALTUNG
4	630015 09 630015 10	FUSE (100 mA) FUSE (16 A)	FUSIBILE (100 mA) FUSIBILE (16 A)	FUSIBLE (100 mA) FUSIBLE (16 A)	SCHMELZSICHERUNG (100 mA) SCHMELZSICHERUNG (16 A)
5	470000 07	SCREW	VITE	VIS	SCHRAUBE
6	620404 04	WATER LEVEL SENSOR	SENSORE LIVELLO ACQUA	CAPTEUR NIVEAU EAU	WASSERNIVEAUFÜHLER
7	620404 03	HALL EFFECT SENSOR	SENSORE EFFETTO HALL	CAPTEUR EFFECT HALL	HALL EFFEKT-FÜHLER
8	620404 01	CONDENSER TEMP. SENSOR	SENSORE TEMP. CONDENSATORE	CAPTEUR TEMP. CONDENSEUR	KONDENSATORTEMPERATURFUEHLER
9	620404 10	EVAPORATOR TEMP. SENSOR	SENSORE TEMP. EVAPORATORE	CAPTEUR TEMP. ÉVAPORATEUR	VERDAMPFERTEMPERATURFUEHLER
10	785086 00	ICE LEVEL CONTROL ASSY	ASS. CONTR. LIVELLO GHIACCIO	ENS. DETECTEUR NIVEAU GLACE	EISNIVEAUFUEHLEREINHEIT

**COMPRESSOR CHART - TABELLA COMPRESSORI - TABLEAU COMPRESSEUR - KOMPRESSOR KARTE**

MODEL MODELLO MODELE MODELL	VOLTS TENSIONE TENSION SPANNUNG	COMPRESSOR MODEL MOD. COMPRESSORE TYPE COMPRESSEUR KOMPRESSOR TYP	COMPRESSOR COMPRESSORE COMPRESSEUR KOMPRESSOR	RELAY RELÉ RELAIS RELAIS	PROTECTOR PROTETTORE PROTECTEUR SCHUTZGERAT	START CAPACITOR CAPACITÀ D'AVV. CAPACITÉ DE DEMARRAGE START KONDENSATOR	RUN CAPACITOR CAPACITÀ DI MARCIA CAPACITÉ PERMANENCE BETRIEB KONDENSATOR
MF 30	115/60/1						
MF 30	230/60/1						
MF 30	220/50/1	U.H. P 12 TN	670097 03	620168 19	620058 59	620167 27	620167 28

**ELECTRIC COMPONENTS CHART - TABELLA COMPONENTI ELETTRICI - TABLEAU COMPOSANTS ELECTRIQUE - ELEKTRISCHEKARTE**

MODEL MODELLO MODELE MODELL	VOLTS TENSIONE TENSION SPANNUNG	GEAR MOTOR ASSY ASS. MOTORIDUTTORE ENS. MOTOREDUCTEUR GETRIEBEMOTOREINHEIT	FAN MOTOR ONLY MOTORE VENTILATORE MOTEUR VENTILATEUR LUFTEH MOTOR	DRIVE MOTOR CAPACITOR CAPACITÀ MOTORE RIDUTT. CONDENSATEUR MOTEUR REDUCT. KONDENSATOR	P.C. BOARD SCHEDA ELETTRONICA CARTE ELECTRONIQUE ELEKTRONISCHE KARTE
MF 30	115/60/1	794225 14	*****	620292 00	620403 04
MF 30	230/60/1	794225 13	620003 22	620292 04	620403 03
MF 30	220/50/1	794225 13	620003 22	620292 04	620403 03