

Pos.	N. Codice	Descrizione	Denomination	Description	Bezeichnung
1	340834	Carrozzeria B24	Carrosserie B24	Base B24	Karosserie B24
1	340836	Carrozzeria B25	Carrosserie B25	Base B25	Karosserie B25
2	210402	Paracolpi	Protection	Pad	Türdämpfer
3	320623	Cerniera	Patte	Door support	Halteplatte
4	160803	Guarnizione	Joint	Gasket	Dichtung
5	320923	Portina	Porte	Door	Tür
6	381403	Scrocchetto	Fermeture porte	Door catch	Schnappverschluss
7	170801	Maniglia	Poignée	Door handle	Türgriff
8	300156	Vite TCB M5x20	Vis TCB M5x20	Screw 5MAx20	Schraube 5MAx20
9	290701	Dado cieco	Ecrou	Lock nut	Mutter
0	161104	Copertura	Panneau	Back-cover	Abdeckung
1	110178	Pannello elett.B24	Tableau commande	Electric panel	E-Tafel
1	110179	Pannello elett.B25	Tableau commande	Electric panel	E-Tafel
2	210202	Piedino	Pied	Foot	Fuss

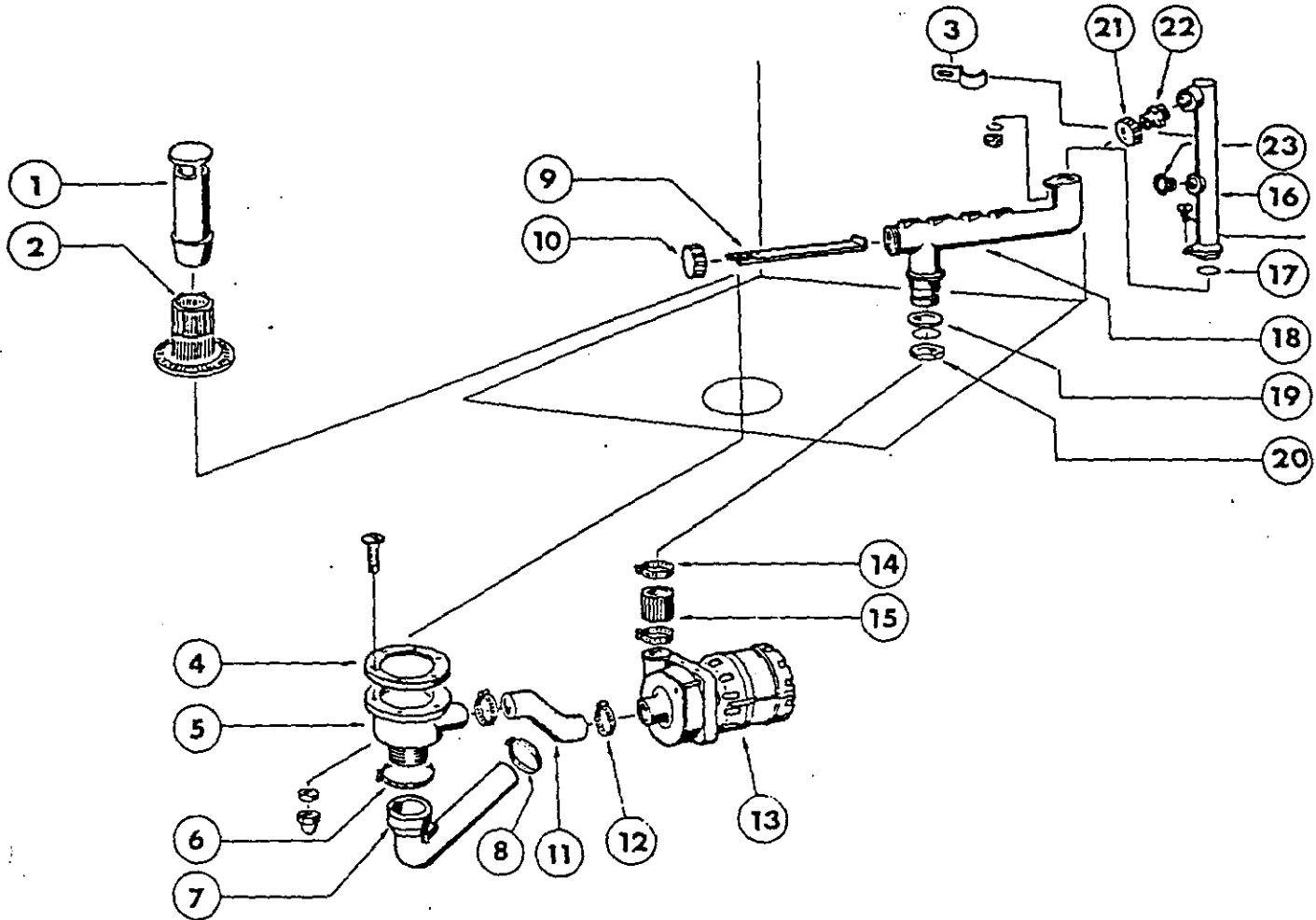

Pos.	N. Codice	Descrizione	Denomination	Description	Bezeichnung
1	180704	Troppopieno	Trop plein	Overflow pipe	Überlaufstutzen
2	180809	Filtro	Filtere	Strainer	Filter
3	330611	Fermo braccio sup.	Arrêt	Tie rod	Schelle
4	200436	Guarnizione	Joint	Gasket	Dichtung
5	180210	Tronchetto	Tronc	Pump suction	Ansaugstutzen
6	450109	Fascetta 50-65	Collier	Clamp	Schlauchselle
7	200345	Tubo scarico	Durite	Drain hose	Ablaufschlauch
8	450114	Fascetta 22-32	Collier	Clamp	Schlauchselle
9	320624	Piastrina	Patte	Support	Platte
10	160710	Tappo per tubo	Bouchon	Plug	Propfen
11	200719	Tubo aspirazione	Tuyau	Suction hose	Ansaugschlauch
12	450106	Fascetta	Collier	Clamp	Schlauchselle
13	100376	Pompa 0,25 HP	Pompe	Pump	Pumpe
13	100377	Pompa 0,10 HP	Pompe	Pump	Pumpe
14	450105	Fascetta	Collier	Clamp	Schlauchselle
15	200319	Manicotto	Manchon	Discharge Hose	Verbindungsschlauch
16	170604	Tubo lav.Laterale	Tuyau	Wash pipe	Seitl. Wascharm
17	200819	Guarnizione OR	O-Ring	O-Ring	O-Ring
18	170603	Tubo lav.inf.	Tuyau	Lower wash pipe	Unterer wascharm
19	200412	Guarnizione	Joint	Gasket	Dichtung
20	270106	Ghiera	Embout	Lock nut	Klemmring
21	170908	Ugello	Gicleur	Nozzle	Spüldüse
22	190618	Diffusore	Diffuseur	Deflector	Verteiler
23	170924	Ugello a taglio	Gicleur	Nozzle	Spüldüse

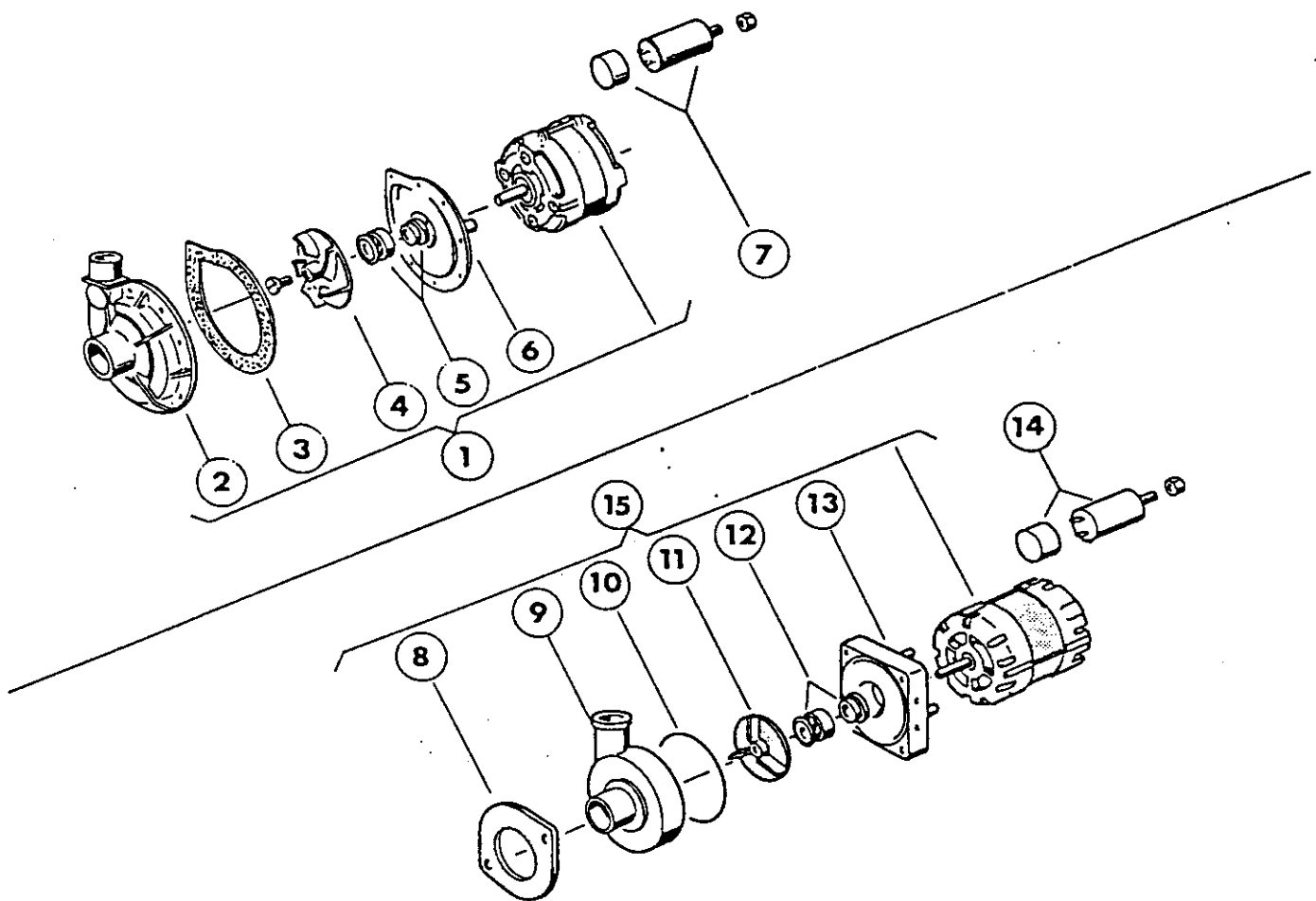

Pos.	N. Codice	Descrizione	Denomination	Description	Bezeichnung
1	100376	Pompa HP 0,25	Pompe	Pump	Pumpe
2	630118	Chiocciola	Escargot	Volute	Pumpengehäuse
3	630414	Guarnizione	Joint	Gasket	Dichtung
4	631625	Girante	Turbine	Impeller	Lauftrad
5	630514	Tenuta meccanica	Joint.presse ét.	Pump seal	Mechanische Dichtung
6	630224	Coperchio	Couvercle	Cover	Schild
7	631206	Condensatore 10 μ F	Condensateur	Condenser	Kondensator
8	630225	Flangia	Flasque	Flange	Flansch
9	630117	Chiocciola	Escargot	Volute	Pumpengehäuse
10	630412	Guarnizione OR	O-Ring	O-Ring	O-Ring
11	631622	Girante	Turbine	Impeller	Lauftrad
12	630511	Tenuta meccanica	Joint presse ét.	Pump seal	Mechanische Dichtung
13	630221	Coperchio	Couvercle	Cover	Schild
14	631208	Condensatore 5 μ F	Condensateur	Condenser	Kondensator
15	100377	Pompa HP 0,10	Pompe	Pump	Pumpe

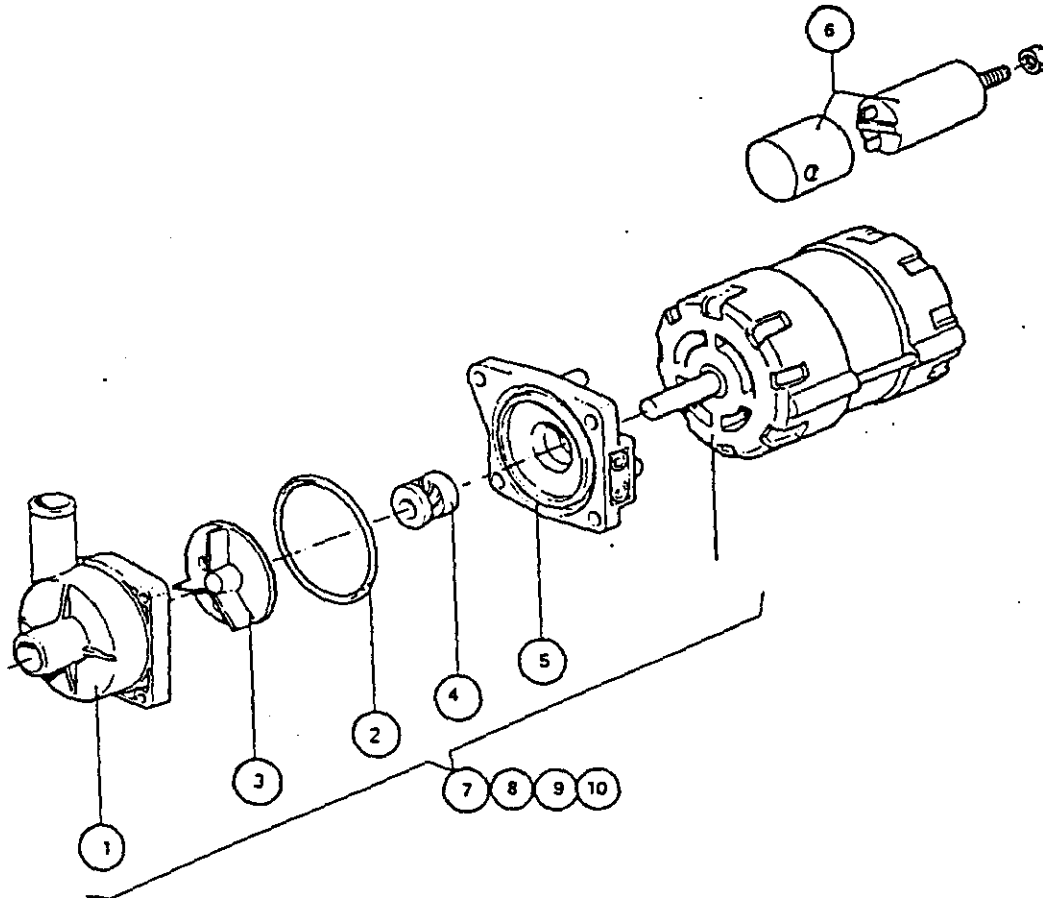

OS.	CODICE	DESCRIZIONE	DENOMINATION	DESCRIPTION	BEZEICHNUNG
1	630120	CHIOCCIOLA	ESCARGOT	VOLUTE	PUMPENGEHAUSE
2	200834	GUARNIZIONE OR	O-RING	O-RING	O-RING
3	631632	GIRANTE 50 Hz	TURBINE	IMPELLER	LAUFRAD
		GIRANTE 60 Hz	TURBINE	IMPELLER	LAUFRAD
4	630501	TENUTA MECCANICA	JOINT PRESSE ETOUPE	PUMP SEAL	MECHANISCHE DICHTUNG
5	630234	COPERCHIO	COUVERCLE	COVER	SCHILD
5	631208	CONDENSATORE 5 µF	CONDENSATEUR	CONDENSER	KONDENSATOR
7	100628	POMPA Hp 0,12 220 V 50 Hz	POMPE	PUMP	PUMPE
8	100644	POMPA Hp 0,12 240 V 50 Hz	POMPE	PUMP	PUMPE
9		POMPA Hp 0,12 250 V 50 Hz	POMPE	PUMP	PUMPE
10		POMPA Hp 0,12 220 V 60 Hz	POMPE	PUMP	PUMPE

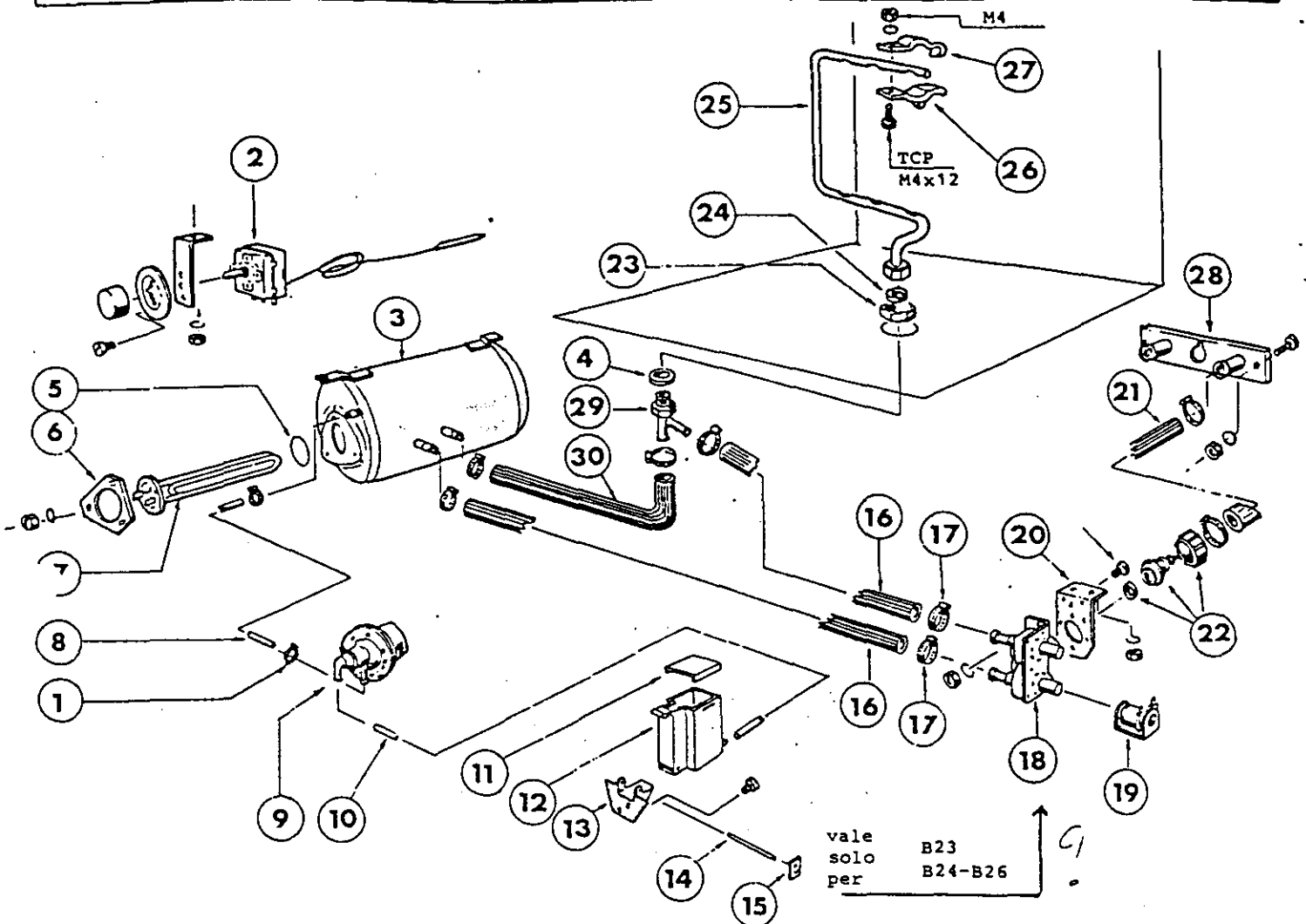

Pos	N. Codice	Descrizione	Denomination	Description	Bezeichnung
1	450123	Fascetta	Collier	Clamp	Schlauchselle
2	120501	Termostato boiler	Thermostat	Thermostat	Thermostat
3	330311	Boiler quadrato	Surchauffeur	Square booster	Viereck. Durchlauferhitzer
3	330316	Boiler rotondo	Surchauffeur	Round booster	Runddurchlauferhitzer
4	460502	Guarnizione	Joint	Gasket	Dichtung
5	200820	Guarnizione OR	O-Ring	O-Ring	O-Ring
6	110364	Ferma resistenza	Patte fissage résis	Heater plate	Heizkörperhalterung
7		Resistenza 2400W	Résistance 2400W	Heating element	Heizkörper
8	200347	Tubo mandata dos.	Tuyau	Inject.outlet tube	Dosierungsauslaufschlauch
9	620120	Dosatore	Doseur	Rinse injector	Glanzmitteldosierer
10	160105	Tubo aspiraz.dos.	Tuyau asp. doseur	Inject.inlet tube	Ansaugschlauch
11	160715	Coperchio conten.	Couvercle	Container cover	Behälterdeckel
12	190802	Contentore brill.	Container prod.rinc	Rinse aid cont.	Glanzmittelbehälter
13	190106	Supporto contenit.	Support	Support	Halterung
14	340484	Perno contenitore	Axe	Pin	Stift
15	450812	Molla fiss.perno	Ressort	Lock plate	Feder
16	200342	Tubo risc.freddo	Tuyau rinc.froid	Cold rinse hose	Kaltspülrohr
17	450104	Fascetta Ø 16-28	Collier	Clamp	Schlauchselle
18	120143	Elettrovalvola	Electrovanne	Solenoid valve	E-Ventil
19	630969	Bobina elettrov.	Bobine électrovanne	Coil	Spule
20	330725	Squadretta	Equerre	Bracket	Winkel
21	200113	Tubo gomma Ø 12x2	Ourite	Rubber hose	Gummischlauch
22	300501	Ghiera 3/4"	Embout	Lock nut	Klemmring
22	301001	Portagomma	Nipples	Hose barb	Schlauchnippel
22	200416	Guarnizione	Joint	Gasket	Dichtung
23	270101	Ghiera	Embout	Lock nut	Klemmring
24	200415	Guarnizione	Joint	Gasket	Dichtung
25	331344	Tubo risciacquo	Tuyau rinçage	Rinse stand pipe	Spülrohr
26	170911	Ugello risciacquo	Gigleur rinçage	Rinse nozzle	Spüldüse
27	170704	Cavallotti fis.ug.	Etrier	Rinse noz.bottom	Befestigung
28	180212	Flangia allacciam.	Flasque	Plate	Flansch
29	510290	Racc. risciacquo	Raccord	Tee	Anschluss
30	200343	Racc.risc. caldo	Tuyau rinçage	Warm rinse hose	Heizspülrohr

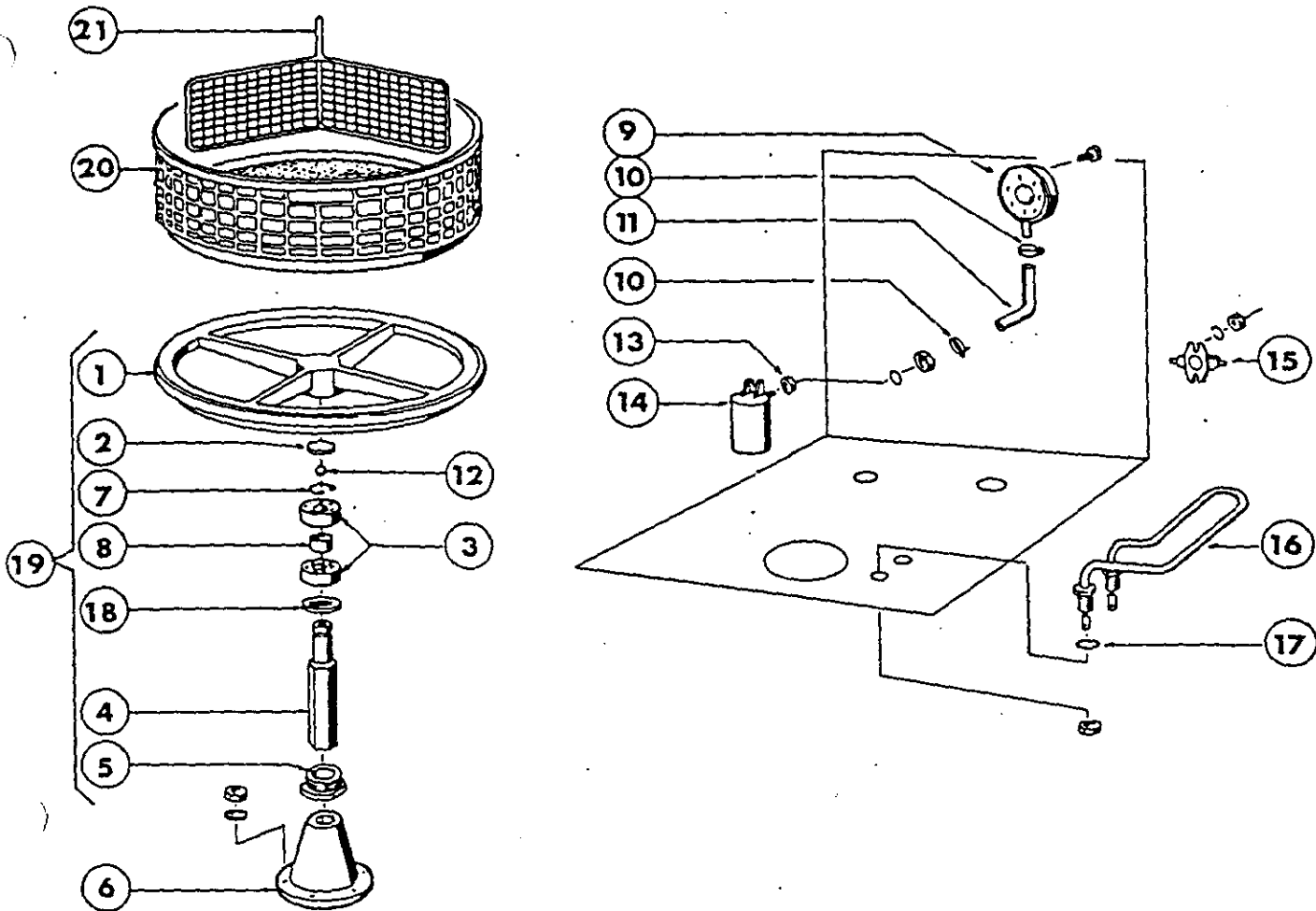

Pos.	N. Codice	Descrizione	Denomination	Description	Bezeichnung
1	170307	Cerchio portacest.	Porte panier	Rack support	Korbträger
2	260529	Rondella	Rondelle	Washer	Gleitring
3	410115	Cuscinetto	Roulement	Ball bearing	Kugellager
4	340472	Alberino	Axe	Spindle	Welle
5	180110	Ghiera	Embout	Lock nut	Klemmring
6	190105	Colonnina	Colonne	Support	Trägerhalterung
7	440809	Anello d'arresto	Seeger	Snap ring	Seeger
8	330817	Distanziale	Entretoise	Spacer	Distanzring
9	130605	Pressostato	Pressostat	Pressure switch	Druckwächter
10	450125	Fascetta elastica	Collier	Clamp	Schlauchschelle
11	200353	Tubo pressostato	Tuyau pressostat	Press. switch hose	Druckwächterschlauch
12	410118	Sfera	Bille	Ball	Kugel
13	200415	Guarnizione	Joint	Gasket	Dichtung
14	161303	Trappola aria	Capuchon air	Air trap	Luftfalle
15	120509	Termostato vasca	Thermostat cuve	Thermostat	Thermostat
16	110235	Resistenza 1500W	Résistance	Heating element	Heizkörper
17	200810	Guarnizione OR	O-Ring	O-Ring	O-Ring
18	160825	Rondella	Rondelle	Washer	Gleitring
19	620203	Gruppo cerchio	Porte panier compl.	Rack supp. assembly	Korbträgereinheit
20	660703	Cestello	Panier	Rack	Korb
21	520612	Inserto	Intercalaire	Insert	Einsatz

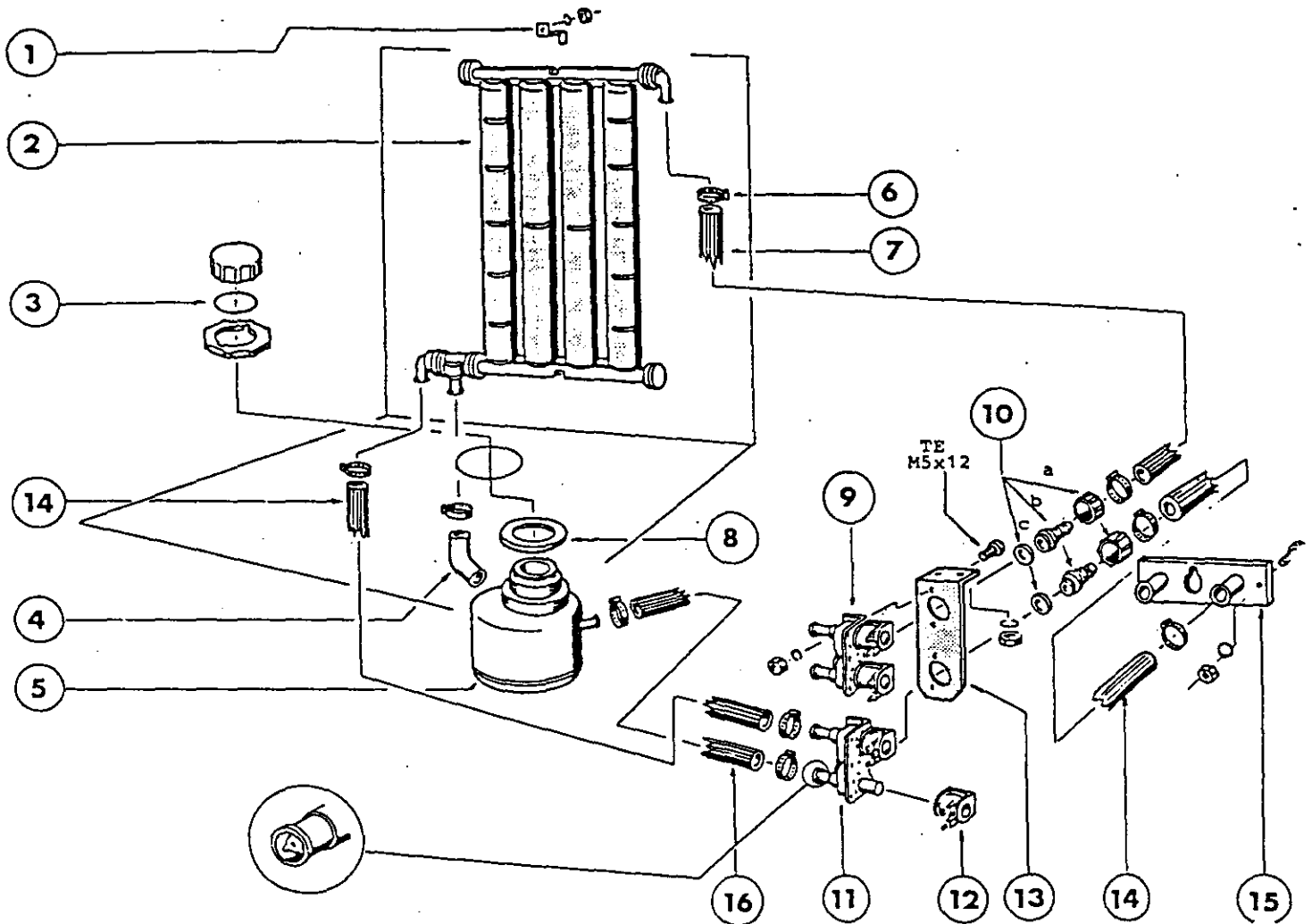

Pos.	N. Codice	Descrizione	Denomination	Description	Bezeichnung
1		Squadretta	Equerre	Bracket	Winkel
2	640209	Addolcitore	Adoucisseur	Water softener	Entkalker
3		Guarnizione OR	Joint	Gasket	Dichtung
4	200341	Pipetta addolcit.	Coude adoucisseur	Hose	Kniestück
5	631302	Contentitore sale	Container sel	Salt container	Salzbehälter
6	450104	Fascetta Ø16÷28	Collier Ø16 ÷ 28	Clamp 16÷28	Schlauchschelle
7	200344	Tubo addolcitore	Durite adoucisseur	Water softener hose	Enthärterrohr
8	200454	Guarnizione	Joint	Gasket	Dichtung
9	120142	Elettrov. risciacq	Electrovanne	Solenoid valve	E-Ventil
10a	300501	Ghiera 3/4"	Embout	Lock nut	Klemmring
11	120144	Elettrov. addolc.	Electrovanne	Solenoid valve	E-Ventil
12	630969	Bobina elettrov.	Bobine électrov.	Coil	Spule
13	330756	Squadretta	Equerre	Bracket	Winkel
14	200113	Tubo Ø 12x22	Durite Ø 12x22	Rubber hose 12x22	Gummischlauch Ø12x22
15	180212	Flangia allacciam	Flasque	Plate	Flansch
16	200340	Tubo conten.sale	Durite container se	Salt cont. hose	Salzbehälterrohr
10b	301001	Portagomma	Nipples	Rubber hose barb	Schlauchnippel
10c	200416	Guarnizione	Joint	Gasket	Dichtung

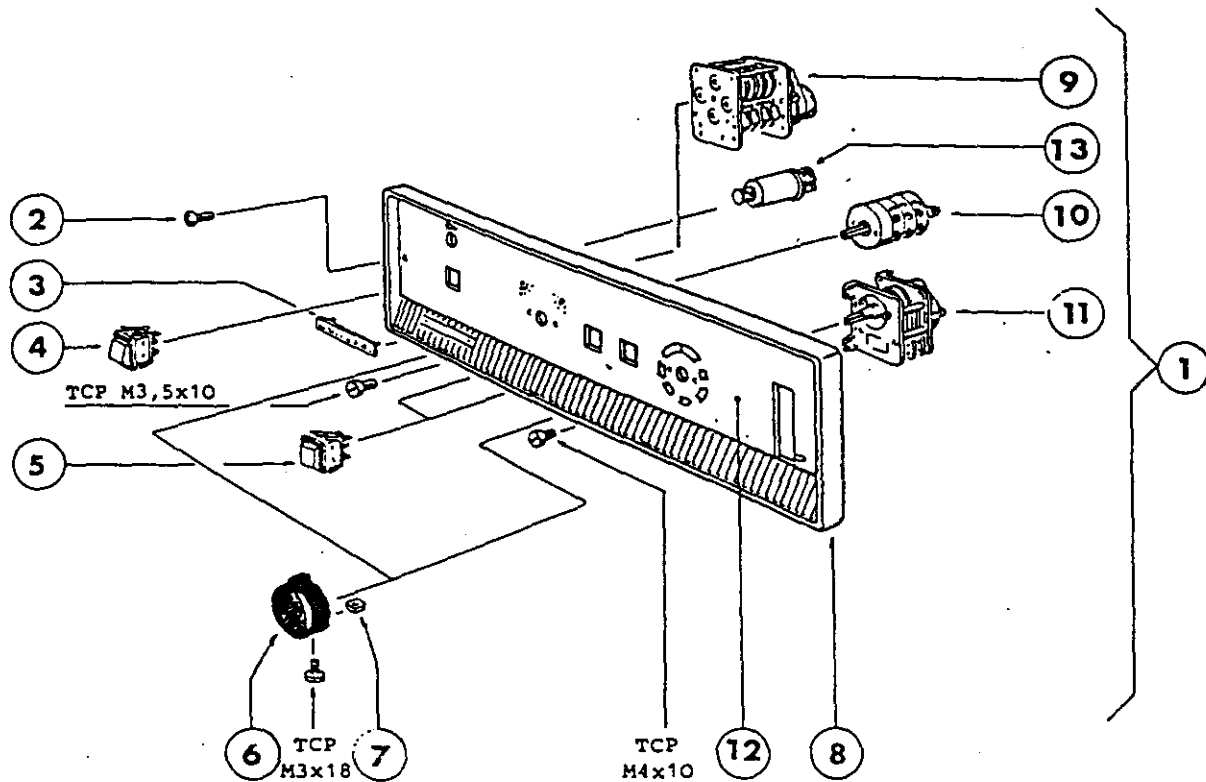

Pos.	N. Codice	Descrizione	Denomination	Description	Bezeichnung
1	110179	Pannello elettr.	Tableau commande	Electric panel	E-Tafel
2	300156	Vite TCB M5x20	Vis	Screw	Scharube
3	460159	Targhetta	Plaque	Name plate	Markenschild
4	130404	Pulsante rigener.	Bouton	Push button	Drucktaste
5	130111	Lampada rossa	Lampe rouge	Red light	Rote Meldeleuchte
5	130112	Lampada verde	Lampe verte	Green light	Grüne Meldeleuchte
6	180111	Manopola	Poignée	Knob	Drehknopf
7	310211	Dado quadro M3	Ecrou M3	Lock nut M3	Mutter M3
8	460144	Targa	Plaque	Front panel	Fronttafel
9	120214	Timer rigeneraz.	Programmateur	Timer	Zeitschalter
10	120708	Interrut. generale	Interrupteur	Switch	Einschalter
11	120213	Timer 120"	Programmateur	Timer	Zeitschalter
12	460167	Targa comandi B25	Plaque	Front panel	Fronttafel
13	631209	Filtro antidist.	Filtre	Anti-noise filter	Entstörfilter