

TAV.207		Struttura	Structure	Structure	Struktur	FGC060	FGP050	FEM060/061
	Codice	Denominazione	Denominaton	Denominaton	Bezeichnung			
1	GAFOC00056	Cassone forno	Caisson	Oven body	Ofenschublade	x	x	x
2	RTCU700002	Attacco griglia laterale	Attaque latérale	Lateral connection	Seitenanschluß	x	x	x
3	GAFOC00027	Disco copriforo	Disque	Disk	Scheibe	x	x	x
4	GAFOC00030	Cerniera superiore porta	Charnière supérieure	Upper hinge	Linke Türangel	x	x	x
5	GAFOC00031	Cerniera inferiore porta	Charnière inférieure	Lower door hinge	Untere Türangel	x	x	x
6	MPGOM03P00	Guarnizione vetro porta	Guarniture porte	Oven door gasket	Türdichtung	x	x	x
7	GAFOC00001	Porta forno	Porte du four	Oven door	Ofentür	x	x	x
8	RTFOC00008	Cristallo porta forno	Verre porte four	Oven door glass	Ofentürglas	x	x	x
9	RTFOC00007	Maniglia serratura	Poignée porte four	Oven door handle	Ofentürgriff	x	x	x
10	PAFOC00008	Controporta forno	Contre porte du four	Oven counter door	Gegentür	x	x	x
11	PAFOC00007	Protezione serratura porta	Protection de la serrure	Lock guard	Schloßschutz	x	x	x
12	PAFOC00085	Prolunge sinistra facciata	Rollonge gauche facade	Left facade extension	Verlängerung linke Front	x	x	x
13	RTFOC00093	Guarnizione porta forno Cassetto	Guarniture porte du four	Oven door gasket	Türdichtung	x	x	x
14	GAFOC00048	Cassetto	Tiroir	Drawer	Kasten	x	x	x
15	PAFOC00181	Traversa antigoccia	Traverse anti-goutte	Anti-drip crosspiece	Tropfschutzquerstange	x	x	x
16	PAFOC00084	Prolunga destra facciata	Rollonge droite facade	Right facade extension	Verlagerung rechte Front	x	x	x
17	PAFOC00080	Coprilana inferiore	Panneau couvre isolant	Insulating panel cover	Isoliermaterialverkleidung	x	x	x
18	PACU800150	Pannello isolante	Panneau isolant	Insulating panel	Isolier tafel	x	x	x
19	GAFOC00059	Basamento	Soubassement	Base	Untergestell	x	x	x
20	GAFOC00057	Cruscotto	Panneau de contrôle	Control panel	Stirnbrett	x	x	x
21	RTFOC00035	Microinterruttore	Microswitch	Microswitch	Microswitch	x	x	x
22	PAFOC00023	Coprilana destro	Panneau couvre isolant	Insulating panel cover	Isoliermaterialverkleidung	x	x	x
23	RTFOC00086	Piedino	Pied	Foot	Inox-Fuß	x	x	x
24	PAFOC00082	Fianco inox	Côté inox	Inox side	Inox-Seite	x	x	x
25	GAFOC00019	Supporto ventola	Support ventilateur	Fan support	Lautradsupport	x	x	x
26	PAFOC00081	Coprilana inf. posteriore	Panneau couvre isolant	Insulating panel cover	Isoliermaterialverkleidung	x	x	x
27	PAFOC00024	Coprilana posteriore	Panneau couvre isolant	Insulating panel cover	Isoliermaterialverkleidung	x	x	x
28	PAFOC00083	Posteriore inox	Panneau postérieur inox	Inox back panel	Inox-Rückwand	x	x	x
29	PAFOC00022	Coprilana sinistro	Panneau couvre isolant	Insulating panel cover	Isoliermaterialverkleidung	x	x	x
30	PAFOC00136	Protezione comp. elettrici	Protection composant électriques	Electrical components guard	Schutz elektrischer Komponenten	x	x	x
31	PAFOC00141	Coprilana superiore	Panneau couvre isolant	Insulating panel cover	Isoliermaterialverkleidung	x	x	x
32	GAFOC00058	Coperchio	Couvercle	Cover	Topfdeckel	x	x	
32	GAFOC00086	Coperchio	Couvercle	Cover	Topfdeckel			x
33	GAFOC00005	Serratura porta forno	Serrure porte four	Over door lock	Ofentürschloß	x	x	x
34	RTFOC00057	Zoccolo centrale serratura	Prise centrale serrure	Central connection lock	Mittlerer Anschluß	x	x	x
35	RTFOC00005	Zoccolo esterno serratura	Prise extérieure serrure	External connection lock	Äußerer Anschluß	x	x	x
36	RTFOC00009	Gancio fisso serratura	Crochet fixe de la serrure	lock fixed hook	Fester Schloßnaken	x	x	x
37	RTBF800021	Gommino porta forno	Bouchon de la porte	Door rubber cap	Türgummi	x	x	x
38	RTFOC00202	Guarnizione portalampada	Garniture	Gasket	Dichtung	x	x	x
39	RTFOC00201	Vetro portalampada	Verre protège ampoule	Lamp-holder glass	Leuchtenhaltungsglas	x	x	x
40	RTFOC00037	Lampada 25W 220V	Ampoule 25W 220V	Lamp 25W 220V	Leuchte 25W 220V	x	x	x
41	RTFOC00036	Portalampada	Douille	Lamp-holder	Leuchtenhalterung	x	x	x
42	RTFOC00060	Asta posteriore scarico cond.	Antenne arrière	Rear rod	Hintere Stange	x	x	x
43	RTFOC00109	Asta trasversale scarico conden.	Antenne transversale	Transverse rod	Queratange	x	x	x
44	RTFOC00056	Manopola scarico condensa.	Manette évacuation condens.	Moisture drain knob	Drehknopf Kondenswasserablaß	x	x	x

TAV.207		Struttura	Structure	Structure	Struktur	FGC060	FGP050	FEM060/061
	Codice	Denominazione	Denominaton	Denominaton	Bezeichnung			
45	RTFOC00062	Asta anteriore scarico cond.	Antenne avant	Front rod	Vordere Stange	×	×	×
46	RTFOC00302	Anello tenuta perno motore	Rondelle de joint	Ring	Ring	×	×	×
47	RTFOC00124	Gomito scarico cond.	Coude évacuation condensation	Moisture drain elbow	Kondenswasserablaßkniestück	×	×	×
48	RTFOC00059	Asta posteriore scarico cond.	Antenne arrière	Rear rod	Hintere Stange	×	×	×
49	RTFOC00152	Rampa scarico cond.	Rampe évacuation condensation	Moisture drain ramp	Kondenswasserablaßrampe			×
49	RTFOC00052	Rampa scarico cond.	Rampe évacuation condensation	Moisture drain ramp	Kondenswasserablaßrampe	×	×	×
50	GAFOC00061	Camino esterno	Cheminée intérieur	Interne chimney	Innenschornstein	×	×	×
51	AFC0000090	Camino antivento	Cheminée antirefuleur	Chimney	Schornstein	×	×	×
52	PAFOC00092	Pannello inferiore	Panneau inférieur	Lower panel	Untere Tafel	×	×	×
53	PAFOC00087	Deviatore fumi	Aiguilleur des fumées	Throttle	Rauchabweiser	×	×	×
54	MPISO00013	Pannealo isolante	Panneau isolant	Insulating panel	Isolier tafel	×	×	×

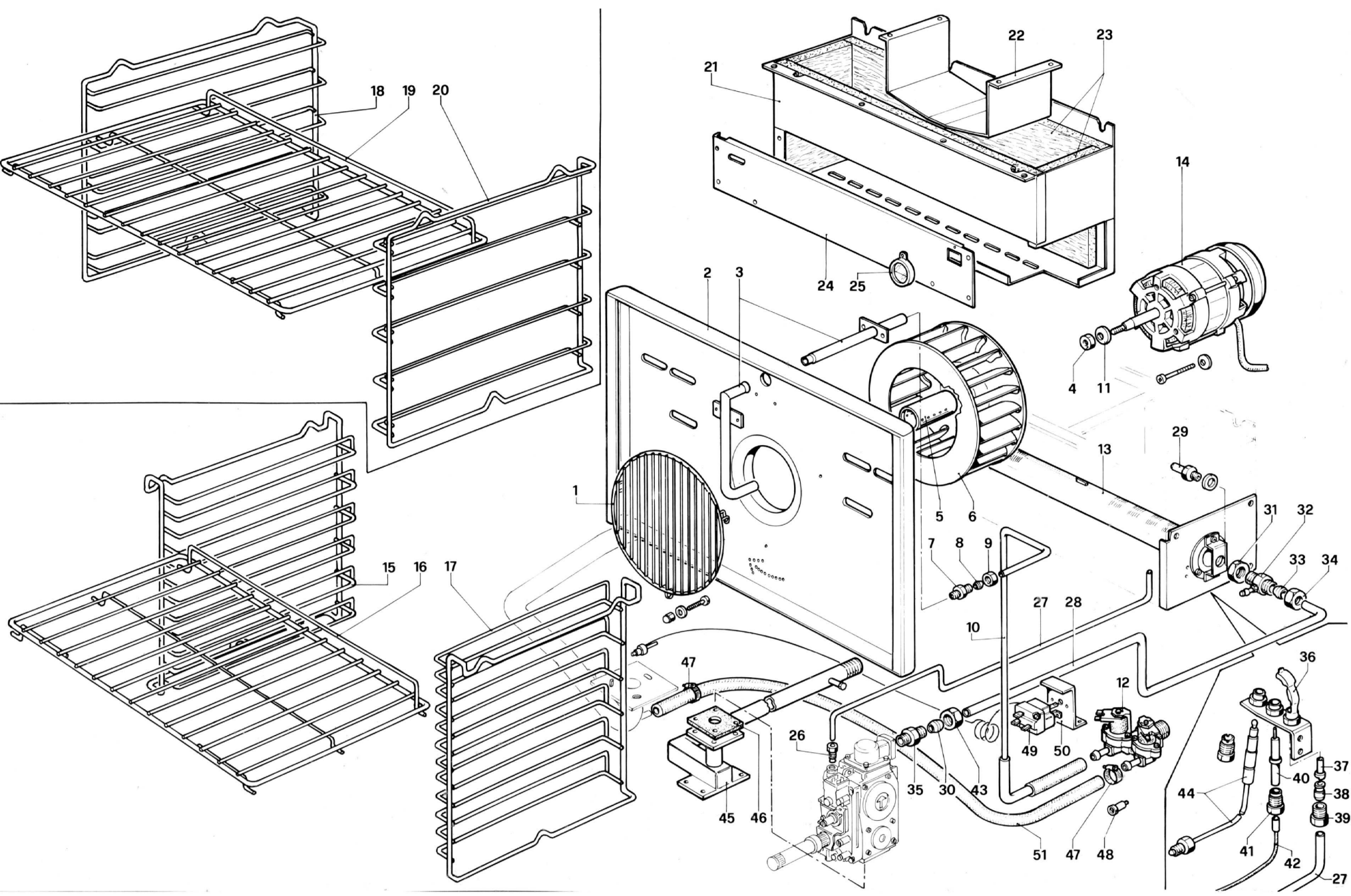

TAV.208		Griglie e impianto gas	Grilles et installation gaz	Grilles and gas system	Gitter und Gasanlage	FEC060/FGP050	FGM060/061	FMM060/061
Codice	Denominazione	Denominaton	Denominaton	Bezeichnung				
1	RTFOC00014	Griglia protezione ventilatore	Grille ventilateur	Fan grille	Ventilatorgitter	x	x	x
2	GAFOC00020	Convogliatore aria	Coiffe ventilateur air	Air duct	Fuffförderer	x	x	x
3	RTFOC00018	Umidificatore	Humidificateur	Humidifier	Befeuchter	x	x	x
5	RTFOC00155	Nebulizzatore	Nébulisateur	Atomizer	Zersträuber	x	x	x
6	RTFOC00012	Girante ventilatore	Couronne mobile ventilateur	Fan wheel	Ventilatorlau frad	x	x	x
7	RTFOC00019	Iniettore umidificatore	Injecteur humidificateur	Injecteur for humidifier	Einspritzer für Befeuchter	x	x	x
8	RTCU800183	Bicone Ø 6	Bicone pour tube Ø 6	Bicone for pipe Ø 6	Zweikegel Ø 6	x	x	x
9	RTFOC00020	Calotta per tubo Ø 6	Ecrou por tube Ø 6	Nut for pipe Ø 6	Mutter für Schlauch Ø 6	x	x	x
10	RTFOC00021	Tubo alimentazione umidificatore	Tube alimentation	Feeding pipe	Versorgungsrohr	x	x	x
12	RTFOC00022	Elettrovalvola	Electrovanne	Solenoid valve	E-Ventil	x	x	x
13	GAFOC00064	Brucciore	Brûleur	Burner	Brenner	x	x	x
14	RTFOC00011	Motore elettrico	Moteur électrique	Electric motor	E-Motor	x	x	x
15	RTFOC00019	Griglia laterale sinistra (FGC060)	Grille latérale gauche (FGC060)	Left lateral grate (FGC060)	Linker Seitenrost (FGC060)	x		
15	RTFOC00180	Griglia laterale sinistra	Grille latérale gauche	Left lateral grate	Linker Seitenrost		x	x
16	RTFOC00017	Griglia forno (FGC060)	Grille du four (FGC060)	Oven grate (FGC060)	Ofenrost (FGC060)	x		
16	RTFOC00175	Griglia forno	Grille du four	Oven grate	Ofenrost		x	x
17	RTFOC00016	Griglia destra (FGC060)	Grille latérale droite (FGC060)	Right lateral grate (FGC060)	Rechter Seitenrost (FGC060)	x		
17	RTFOC00176	Griglia laterale destra	Grille latéral droite	Right lateral grate	Rechter Seitenrost		x	x
18	RTFOC00081	Griglia laterale sinistro (FGP050)	Grille latérale gauche (FGP050)	Left lateral grate (FGP050)	Linker Seitenrost (FGP050)	x		
19	RTFOC00083	Griglia forno (FGP050)	Grille du four (FGP050)	Oven grate (FGP050)	Ofenrost (FGP050)	x		
20	RTFOC00082	Griglia laterale destra (FGP050)	Grille latérale droite (FGP050)	Right lateral grate (FGP050)	Rechter Seitenrost (FGP050)	x		
21	GAFOC00063	Camera di combustione	Chambre de combustion	Combustion chamber	Brennkammer	x	x	x
22	PAFOC00104	Deflettore bruciore	Défecteur pour brûleur	Burner deflector	Deflektor	x	x	x
23	MPISO00012	Pannello isolante	Panneau isolant	Insolating panel	Isolier tafel	x	x	x
24	PAFOC00101	Coperchio camera combustione	Panneau antérieur chambre comb.	Combustion chamber face	Brennkammerforderwand	x	x	x
25	RTBF900054	Visore con retro	Doville	Viewer	Monitor	x	x	x
26	RTCU900217	Raccordo e bicone Ø 6	Ecrou et bicone Ø 6	Nut and bicone Ø 6	Mutter und Zweikegel Ø 6	x	x	x
27	PAFOC00098	Tubo alimentazione pilota	Tube pour veilleuse	Pilot pipe	Pilotbrennerrohr	x	x	x
28	PAFOC00097	Tubo alimentazione bruciore	Tube alimentation brûleur	Burner feeding pipe	Brennerversorgungsrohr	x	x	x
29	RTCP800016	Iniettore Ø 1.70 per GPL	Injecteur Ø 1.70 pour GPL	Injector LPG Ø 1.70	Flüssiggas-Einspritzer Ø 1.70	x	x	x
29	RTFOC00102	Iniettore Ø 2.80 gas metano	Injecteur Ø 2.80 pour méthane	Methane injector Ø 2.80	Methangas-Einspritzer Ø 2.80	x	x	x
30	RTCP900088	Bicono Ø 14	Bicone Ø 14	Bicone Ø 14	Zweikegel Ø 14	x	x	x
31	RTCP800013	Controdado 1/2"	Countre écron 1/2"	Lock nut 1/2"	Gegenmutter 1/2"	x	x	x
32	RTCP800012	Supporto iniettore	Support injecteur	Injector support	Einspritzhalterung	x	x	x
33	RTBF800137	Bicono Ø 14	Bicone Ø 14	Bicone Ø 14	Zweikegel Ø 14	x	x	x
34	RTBF800015	Calotta Ø 14	Ecrou pour tube Ø 14	Nut for pipe Ø 14	Mutter für Schlauch Ø 14	x	x	x
35	RTCP900087	Niples 1/2"-M20	Niples 1/2"-M20	Niples 1/2"-M20	Nippel 1/2"-M20	x	x	x
36	RTCP800034	Corpo pilota	Corps veilleuse	Pilot body	Pilotbrenner	x	x	x
37	RTCP800041	Iniettore pilota Ø 0,19 per GPL	Injecteur veilleuse Ø 0.19 pour GPL	LPG pilot injecteur Ø 0.19	Flüssiggas-Einspritzer Ø 0.19	x	x	x
37	RTCP800040	Iniettore Ø 0.36 gas metano	Injecteur veilleuse Ø 0.36 pour méthane	Methane pilot injecteur Ø0.36	Methangas-Einspritzer Ø 0.36	x	x	x
38	RTCU800183	Bicono Ø 6	Bicone Ø 6	Bicone Ø 6	Zweikegel Ø 6	x	x	x
39	RTCU800182	Calotta Ø 6	Ecrou pour tube Ø 6	Nut for pipe Ø 6	Mutter für Schlauch Ø 6	x	x	x
40	RTCP800033	Candela rotonda	Bugie d'allumage	Spark plug	Zündkerze	x	x	x

TAV.208		Griglie e impianto gas	Grilles et installation gaz	Grilles and gas system	Gitter und Gasanlage	FEC060/FGP050	FGM060/061	FMM060/061
	Codice	Denominazione	Denominaton	Denominaton	Bezeichnung			
41	RTCU900215	Raccordo candela pilota	Raccord pour bugie veilleuse	Fitting for pilot spark plug	Anschlußstück	×	×	×
42	RTFOC00128	Cavo accensione	Cable d'allumage	Lighting cable	Zündkabel	×	×	×
43	RTCP900089	Calotta Ø 14	Ecrou pour tube Ø 14	Nut for pipe Ø 14	Mutter für schlauch Ø 14	×	×	×
44	RTFOC00241	Termocoppia 100cm	Thermocouple 100cm	Thermocouple 100cm	Thermoelement 100cm	×	×	×
45	RTFOC00091	Rampa forno	Collecteur du four	Oven collector	Speiserampe	×	×	×
46	RTFOC00100	Guarnizione rampa	Guarnizione	Gasket	Dichtung	×	×	×
47	RTMIN00221	Fascetta Ø 14-22	Collier Ø 14-22	Clamp Ø 14-22	Windel Ø 14-22	×	×	×
48	RTFOC00120	Regolatore elettrovalvola Ø 0,25	Regolateur electrovanne Ø 0,25	Solenoid valve regulator Ø 0,25	E-Ventil Regler Ø 0,25	×	×	×
49	RTFOC00275	Termostato elettrico	Thermostat	Thermostat	Thermostat	×	×	×
50	PACP800062	Squadretta portatermostato	Egierre de fixation therm.	Bracket to fix thermostat	Winkel	×	×	×
51	MPGOM10T00	Tube gomma Ø 10x17	Tuyau Ø 10x17	Pipe Ø 10x17	Rohr Ø 10x17	×	×	×

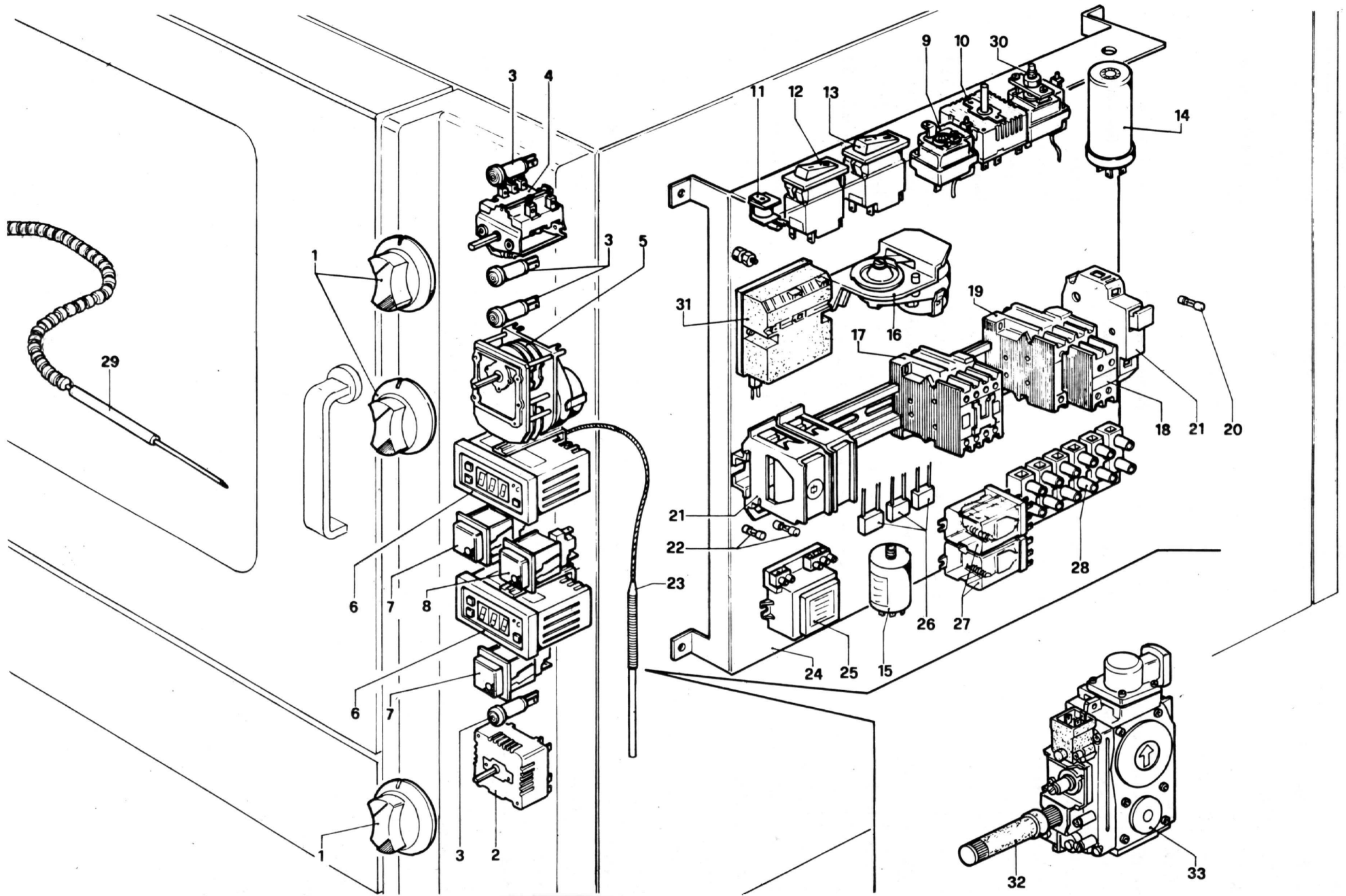

TAV. 232		Apparecchiature elettriche	Appareillages électriques	Electrical equipment	Elektrogeräte	FGMD060/061	FGMD100/101
	Codice	Denominazione	Denominaton	Denominaton	Bezeichnung		
1	RTFOC00055	Manopola comando	Manette de comande	Control knob	Steuerdrehknopf	x	x
2	RTCU800066	Regolatore d'energia	Régulateur d'énergie	Power regulator	Energierегler	x	x
3	RTCU900072	Lampada spia gialla	Lampe témoin jaune	Yellow warning lamp	Gelbe konntrolleuchtenbirne	x	x
4	RTFOC00143	Commutatore	Commutateur du four	Oven warning lamp	Kommutator	x	x
5	RTFOC00030	Timer	Timer	Timer	Timer	x	x
6	RTFOC00029	Termostato elettronico	Thermostat électronique	Electronic thermostat	Elektra-Thermostat	x	x
7	RTFOC00033	Pulsante 2 velocità	Bouton 2 vitesses	Two-speed button	Taste 2 Geschwindigkeit	x	x
8	RTFOC00032	Pulsante luce	Bouton lumière	Light button	Lichttaste	x	x
9	RTFOC00147	Termostato	Thermostat	Thermostat	Thermostat	x	x
10	RTCU800066	Regolatore d'energia	Régulateur d'énergie	Power regulator	Energierегler	x	x
11	RTFOC00046	Ronzatore	Bourdonneur	Buzzer	Summer	x	x
12	RTFOC00044	Termica 0,8A	Interrupteur thermique 0,8A	Overload switch 0,8A	Thermoschutzschalter 0,8A	x	
12	RTFOC00129	Termica 0,6A	Interrupteur thermique 0,6A	Overload switch0,6A	Thermoschutzschalter 0,6A		x
13	RTFOC00045	Termica3A	Interrupteur thermique 3A	Overload switch 3A	Thermoschutzschalter 3A	x	
13	RTFOC00074	Termica 1,8A	Interrupteur thermique 1,8A	Overload switch 1,8A	Thermoschutzhalter1,8A		x
14	RTFOC00053	Condensatore	Condensateur	Condensator	Kondensator	x	x
15	RTFOC00309	Antidisturbo radio	Antiparasitage radio	Antijamming	Funkentstörung	x	x
16	RTFOC00042	Ciclatore 50Hz	Cycleur 50Hz	Buzzer 50Hz	Taktvorrichtung 50Hz	x	x
17	RTFOC00040	Relais FCV	Relais FCV	Relais FCV	Relais FCV	x	x
18	RTFOC00041	Contatti ausiliari	Contacts ausiliaires	Auxiliary contacts	Nebenkontakte	x	x
19	RTFOC00171	Relais	Relais	Relais	Relais	x	x
20	RTFOC00284	Fusibile 6,3A	Fusibile 6,3A	Fuse 6,3A	Schmelzsicherung 6,3A	x	x
21	RTFOC00048	Portafusibile	Porte-fusibile	Fuse-holder	Sicherungsschalter	x	x
22	RTFOC00047	Fusibile 0,1A	Fusibile 0,1A	Fuse 0,1A	Schmelzsicherung 0,1A	x	x
23	RTFOC00034	Termocoppia 100cm	Thermocouple 100cm	Thermocouple 100cm	Thermoelement 100cm	x	x
24	PAFOC00029	Supporto componenti elettrici	Support composants électriques	Electronic components support	Halterung elektrischer Komponenten	x	x
25	RTFOC00039	Transformatore 220/12V	Transformateur el. 220/ 12V	Electric transformator 220/12V	Transformator 220/12V	x	x
26	RTFOC00023	Antidisturbo radio	Antiparasitage radio	Antijamming	Funkentstörung	x	x
27	RTFOC00144	Relais boiler	Relais bouilleur	Boiler relais	Relais	x	x
28	RTBF900045	Morsetteriera 6 poli	Groupe de com. des cables	Terminal bloc 6 poles	Klemmbrett 6 polig	x	x
29	RTFOC00130	Sonda al cuore 55cm	Sonde thermique 55cm	Thermic probe 55cm	Wärmefühler 55cm	x	
29	RTFOC00131	Sonda al cuore 82cm	Sonde therique 82cm	Thermic probe 82cm	Wärmefühler 82 cm		x
30	RTFOC00232	Termostato Limit	Thermostat limit	Limit thermostat	Limit Thermostat	x	x
31	RTBF800129	Accenditore elettrico	Allumage électrique	Electric lightning	Elektrischer Anzünder	x	x
32	RTFOC00098	Prolunga valvola gas	Prolongateur valve	Valve sit extension	Verlängerung	x	x
33	RTFOC00095	Valvola gas	Valve gas	Valve sit	Gasventil	x	x

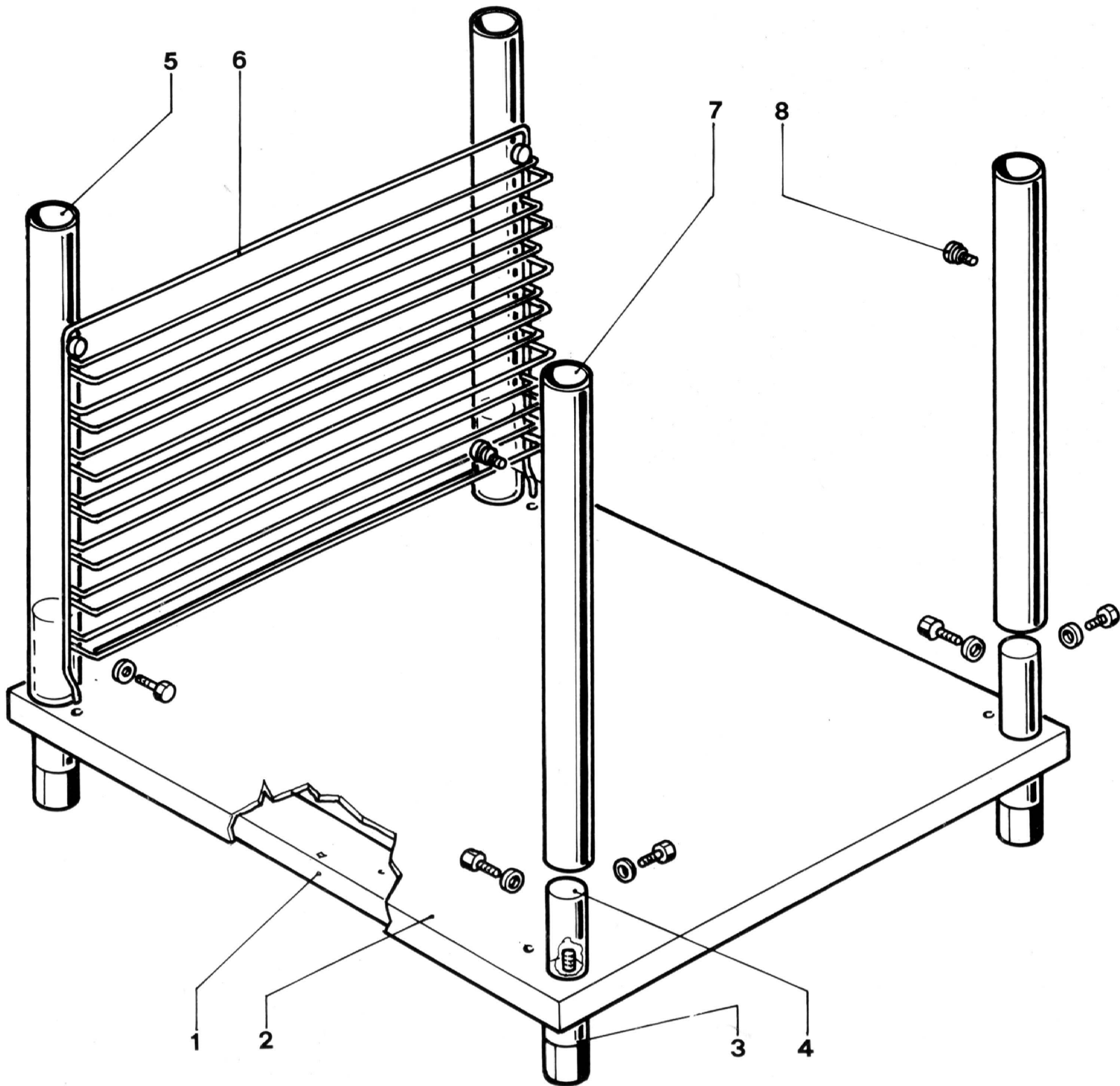

TAV.204		Supporto forno	Support du four	Oven support	Ofenhalterung	
	Codice	Denominazione	Denominaton	Denominaton	Bezeichnung	
1	GAFOC00077	Basamento supporto forno	Soubassement du support	Oven support base	Untergestell	×
2	PAFOC00133	Ripiano supporto forno	Fonde support du four	Oven support bottom	Boden	×
3	RTFOC00119	Piedino	Pied	Foot	Inox-Fuß	×
4	RTFOC00121	Rinforzo gamba	Rentort jambe	Leg bracing	Verstärkung	×
5	PAFOC00134	Gamba sinistra	Jambe gauche	Left leg	Linker Fuß	×
6	RTFOC00122	Griglia laterale	Grille latérale	Lateral grate	Seitenrost	×
7	PAFOC00135	Gamba destra	Jambe droite	Right leg	Rechter Fuß	×
8	RTBF700043	Attacco griglia	Attaque grille	Grate connection	Seitenanschluß	×