

FM1202R SERVICE PARTS

This parts list contains the service parts and wiring diagrams for this model. Check the model number in question to be sure that it is applicable to this parts list.

TABLE OF CONTENTS

Cabinet	2
Refrigeration	3
Water	4
Gearmotor.....	5
Evaporator	6
Control Box.....	7
Remote Condenser	8
Wiring Diagrams.....	9

FM1202R SERVICE PARTS

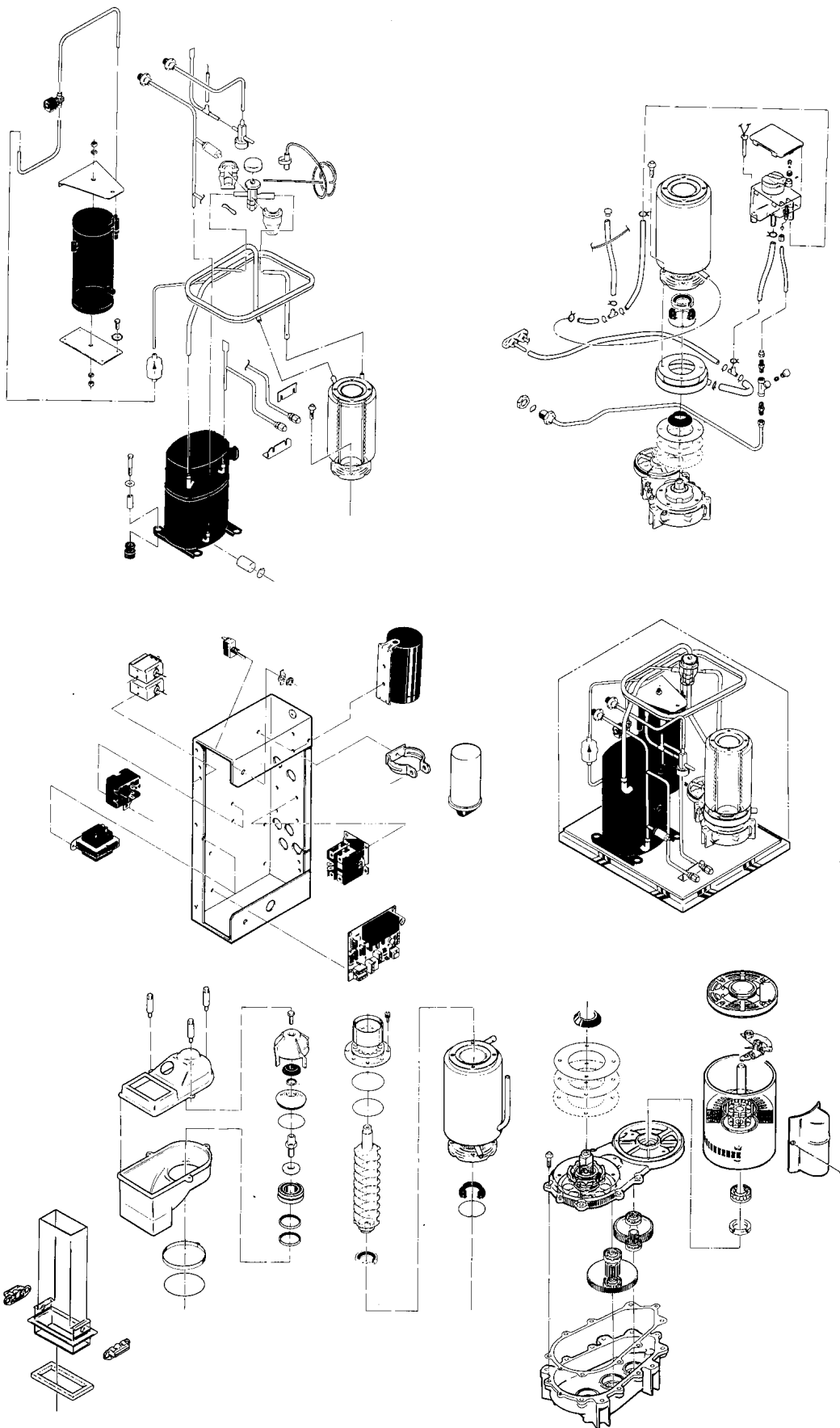

FM1202R SERVICE PARTS

Cabinet Assembly

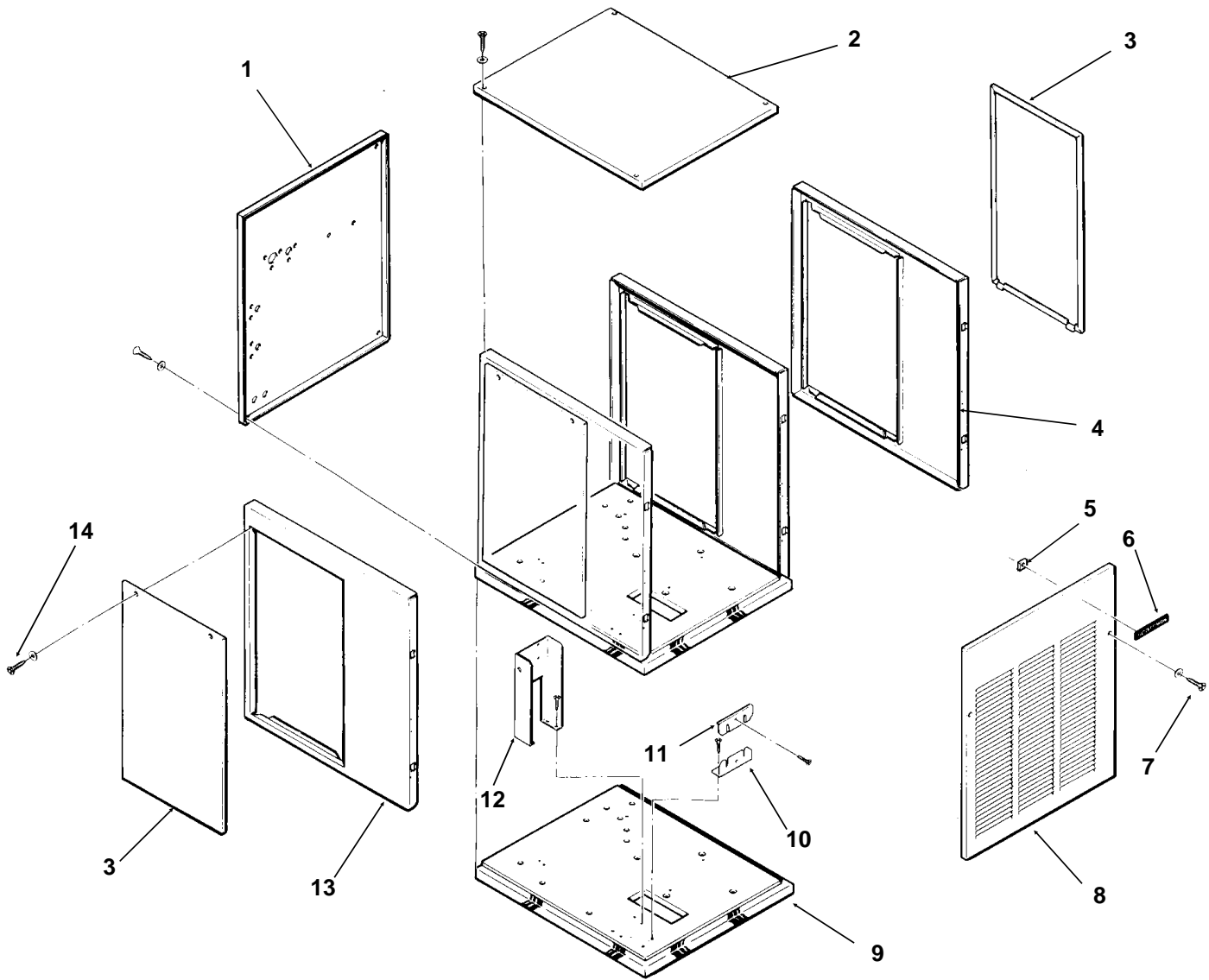

ITEM NUMBER	PART NUMBER	DESCRIPTION	ITEM NUMBER	PART NUMBER	DESCRIPTION
1	A33252-001	Back Panel, Painted	8	A33255-001	Front Panel, Painted
2	A33256-001	Top Panel, Painted		A33255-002	Front Panel, S.S.
	A33256-002	Top Panel, S.S.	9	A34042-001	Base Assembly
3	A34038-001	Service Panel, Painted	10	A31462-001	Tube Bracket
	A34038-002	Service Panel, S.S.	11	A31461-001	Tube Bracket
4	A33292-001	Right Side Panel, Painted	12	A34039-001	Control Box Support
	A33292-002	Right Side Panel, S.S.	13	A32435-001	Left Side Panel, Painted
5	03-0271-00	Speed Clip		A32435-002	Left Side Panel, S.S.
6	15-0711-01	Emblem	14	03-1404-12	Screw
7	03-1419-08	Screw			

FM1202R SERVICE PARTS

Refrigeration System

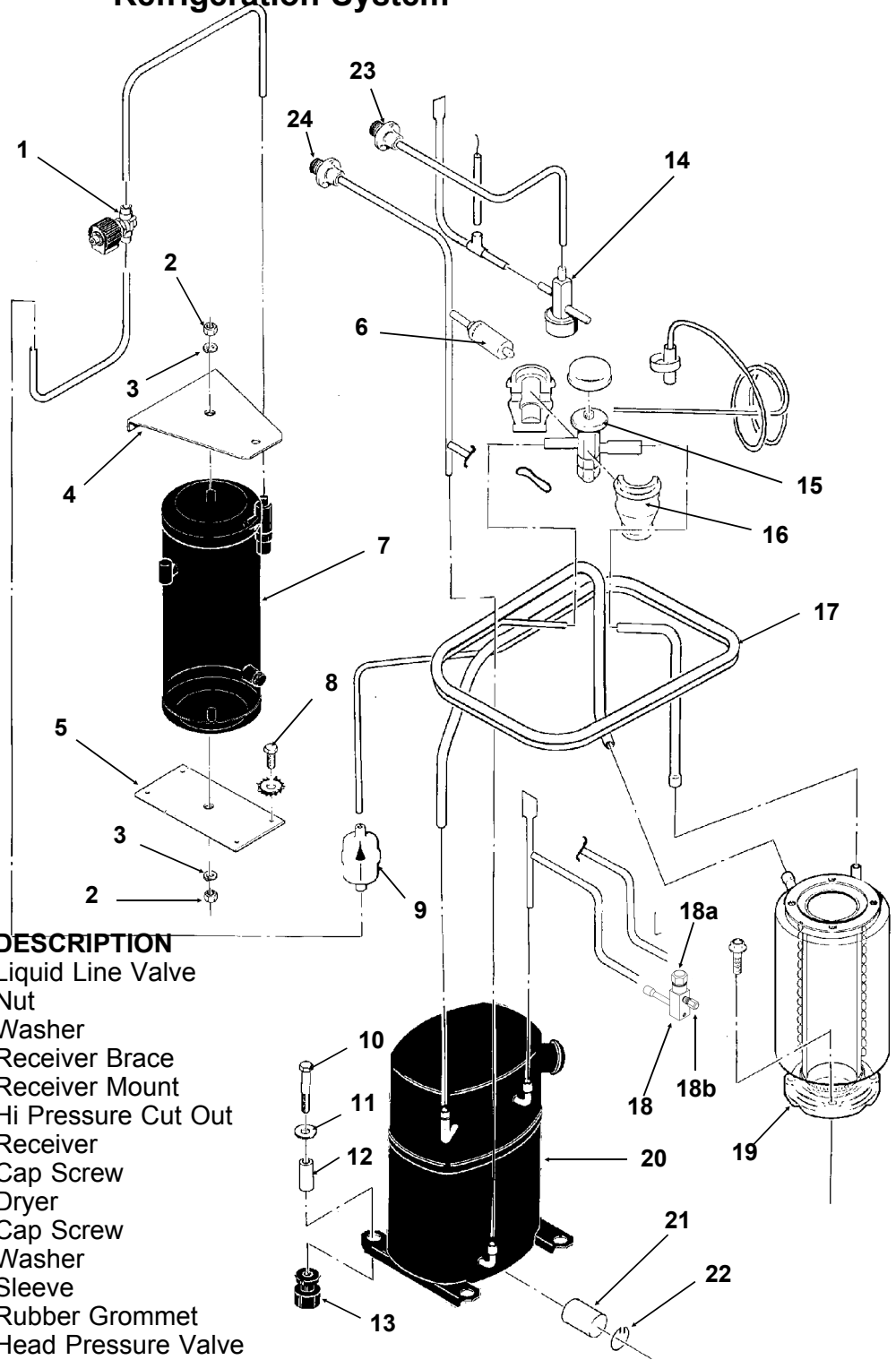

NOTE: Compressors have internal overloads.

ITEM NUMBER	PART NUMBER	DESCRIPTION
1	12-2257-21	Liquid Line Valve
2	03-1406-13	Nut
3	03-1410-06	Washer
4	A32968-001	Receiver Brace
5	A31801-002	Receiver Mount
6	11-0446-27	Hi Pressure Cut Out
7	16-0761-01	Receiver
8	03-1645-01	Cap Screw
9	02-3319-02	Dryer
10	03-1405-20	Cap Screw
11	03-1407-07	Washer
12	18-2300-27	Sleeve
13	18-6800-01	Rubber Grommet
14	11-0422-22	Head Pressure Valve
15	11-0477-20	Thermo Expansion Valve
16	A32961-020	Insulation Kit for TXV
17	A35566-001	Suction Line
18	16-0832-20	Access valve
18a	16-0832-02	Stem cap
18b	16-0832-03	Core cap
19	A32890-020	Evaporator

ITEM NUMBER	PART NUMBER	DESCRIPTION
20	18-8716-23	Compressor 208-230/60/1
21	18-8716-25	Compressor 200-230/60/3
21	18-2308-01	Crankcase Heater
22	18-2309-01	Clip
23	16-0850-03	3/8" Male half
24	16-0850-01	1/2" Male half

FM1202R SERVICE PARTS

Water System, Water Seal

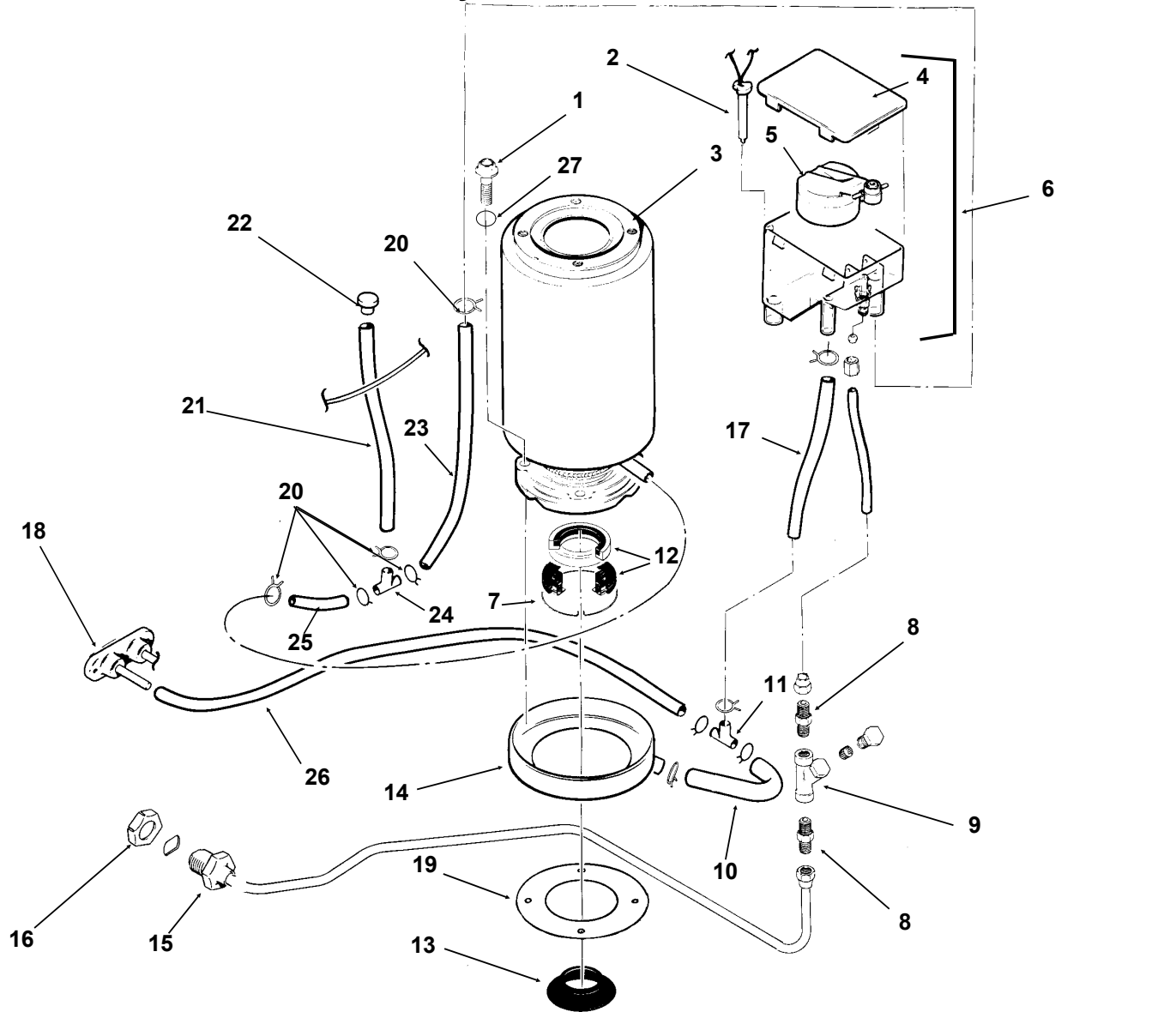

ITEM NUMBER	PART NUMBER	DESCRIPTION	ITEM NUMBER	PART NUMBER	DESCRIPTION
1	03-1405-41	Cap Screw	14	A32050-001	Drip Pan
2	A33101-022	Water Level Sensor	15	A27318-001	Water Inlet Fitting
3	A32890-020	Evaporator	16	03-1394-01	Pal Nut
4	02-2936-01	Res. Cover	17	13-0079-03	Res. Overflow, 8" req.
5	A32907-001	Float Assembly with pin, housing seal, rubber seat, insert & float	18	A34045-001	Drain Casting
	02-3190-01	Rubber seat	19	13-0704-00	Gasket
6	A32929-020	Reservoir Assembly	20	02-2814-08	Clamps
7	A32777-001	Retaining Ring for Seal	21	13-0674-06	Evap. Drain, 14" req.
8	16-0791-01	Half Union	22	13-0840-01	Plug
9	16-0162-00	Strainer	23	13-0674-06	Evap. Inlet Tube, 5" req.
10	13-0079-03	Tube, 3.2" req.	24	16-0670-01	Tee
11	16-0670-02	Tee	25	A33203-001	Tube, Preformed
12	02-0929-23	Water Seal	26	13-0079-03	Drain Tube, 24" req.
13	13-0868-01	Water Shed	27	03-1417-13	Lockwasher

FM1202R SERVICE PARTS

Gearmotor

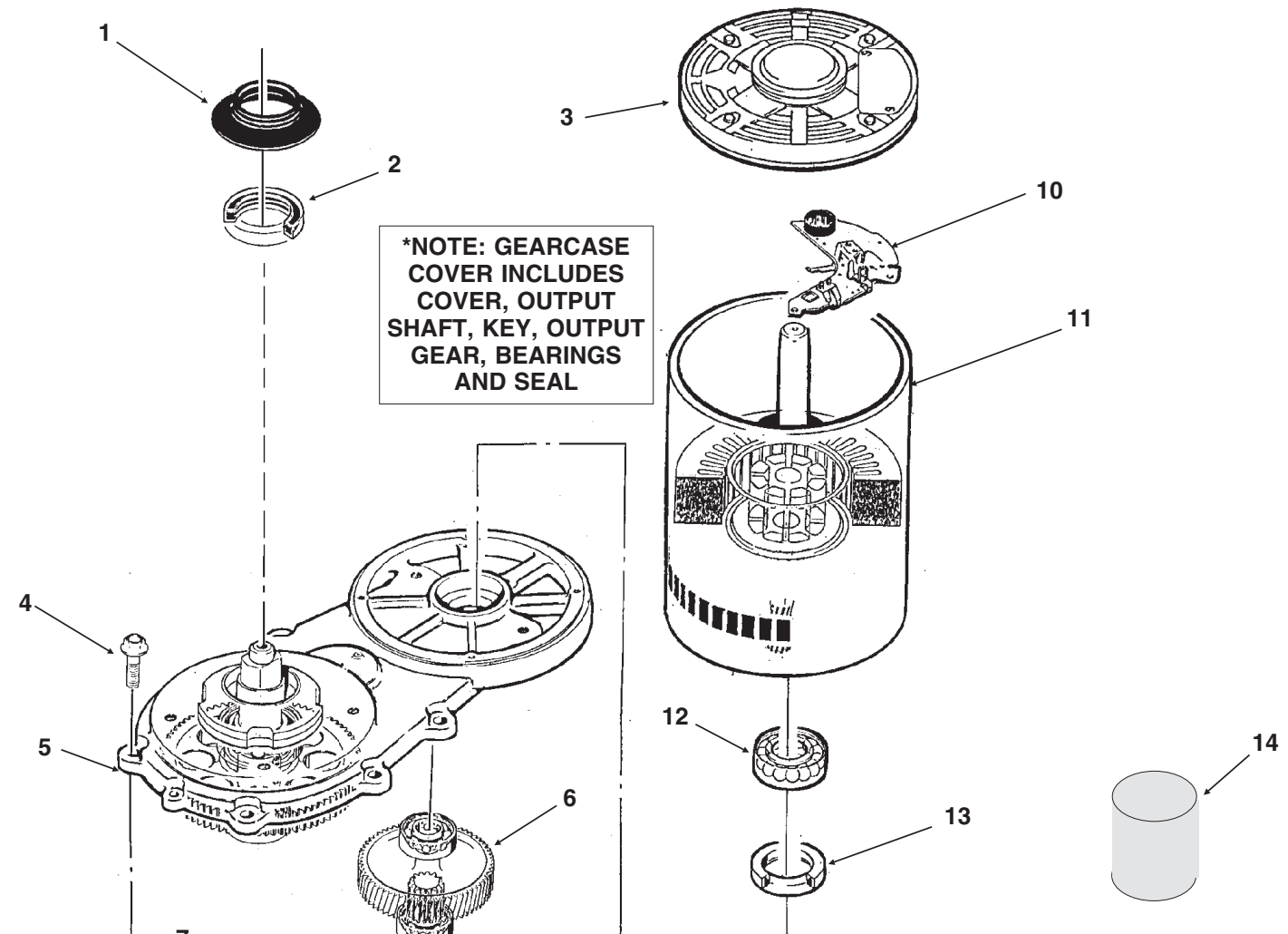

***NOTE: GEARCASE COVER INCLUDES COVER, OUTPUT SHAFT, KEY, OUTPUT GEAR, BEARINGS AND SEAL**

ITEM NUMBER	PART NUMBER	DESCRIPTION
1	13-0868-01	Water Shed
2	A32379-029	Seal
3	no number	End bell
4	A32379-026	Bolt
5	A32379-022	Gearcase Cover*
6	A32379-024	1st Gear and Bearings
7	A32379-023	2nd Gear and Bearings
8	A32379-021	Gasket
9	A32379-020	Gearcase
10	12-2430-24	Start switch, Emerson
	12-2430-44	Start switch, GE split phase
11	12-2430-22	Drive Motor - 208-230
12	12-2430-29	Rotor Bearing, Emerson
	12-2430-49	Rotor bearing, GE split phase
13	A32379-028	Seal, not used on replacement gear reducers or covers after 2/2000
14	A32379-027	Oil, 1 Container
15	A33220-022	Complete Assembly 208-230 volt

Complete assembly includes water shed and drip pan gasket.

A33220-030 Gears, oil & cases, no motor

FM1202R SERVICE PARTS

Evaporator, Bin Controls

Note: Bail clamp, pn A34969-001

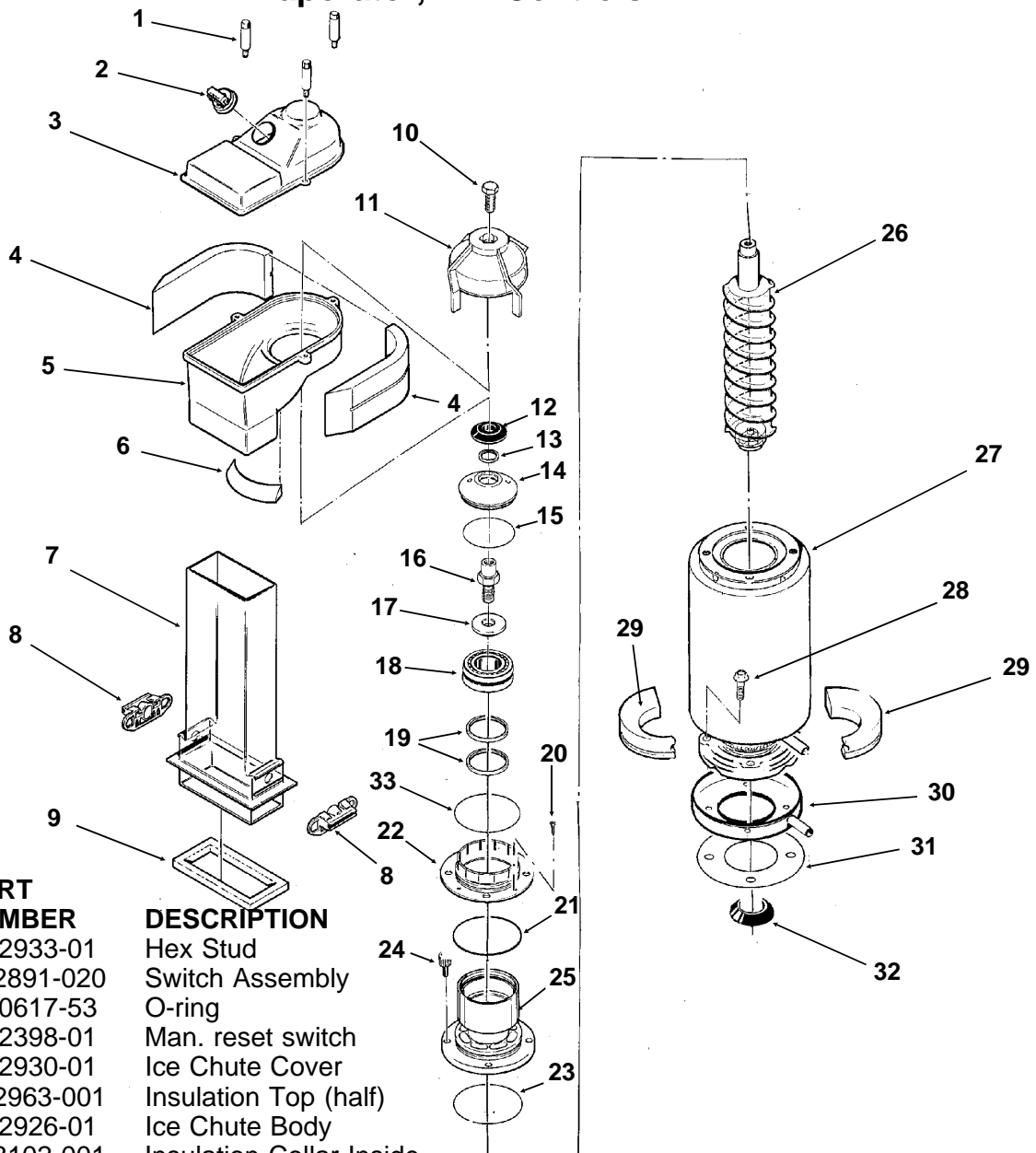

ITEM NUMBER	PART NUMBER	DESCRIPTION	
1.	02-2933-01	Hex Stud	
2.	A32891-020	Switch Assembly	
	13-0617-53	O-ring	
	12-2398-01	Man. reset switch	
3.	02-2930-01	Ice Chute Cover	
4.	A32963-001	Insulation Top (half)	
5.	02-2926-01	Ice Chute Body	
6.	A33102-001	Insulation Collar Inside	
	A35419-020	Strap kit	
7.	02-2929-01	Ice Chute Lower	
8.	A37708-021	Ice level sensors (set of 2)	
9.	A32930-001	Chute Gasket	
10.	03-1405-52	Hex Cap Screw	
11.	02-3001-01	Ice Sweep	
12.	13-0871-01	Water Shed	
13.	02-2978-01	Lip Seal	
14.	02-3128-20	Breaker Cover	
15.	13-0617-54	O-Ring	
16.	08-0660-01	Auger Stud, includes #17	
17.	no number	Thrust Washer, part of #16	
18.	A34559-020	Bearing	
19.	02-2977-01	Lip Seal	
	20.	03-1405-27	Screw
	21.	13-0617-52	O-Ring
	22.	02-2916-01	Slotted Collar
	23.	13-0617-45	O-Ring
	24.	03-1544-08	Soc. Head Screw
	25.	A34505-020	Breaker (Divider) (includes 18 & 19)
	26.	A38071-022	Auger
	27.	A32890-020	Evaporator
	28.	03-1405-41	Cap Screw
	29.	A32962-001	Insulation Bot. (half)
		A32962-002	Insulation (half)
	30.	A32050-001	Drip Pan
	31.	13-0704-00	Drip Pan Gasket
	32.	13-0868-01	Water Shed
	33.	13-0617-49	O-ring

FM1202R SERVICE PARTS

Control Box

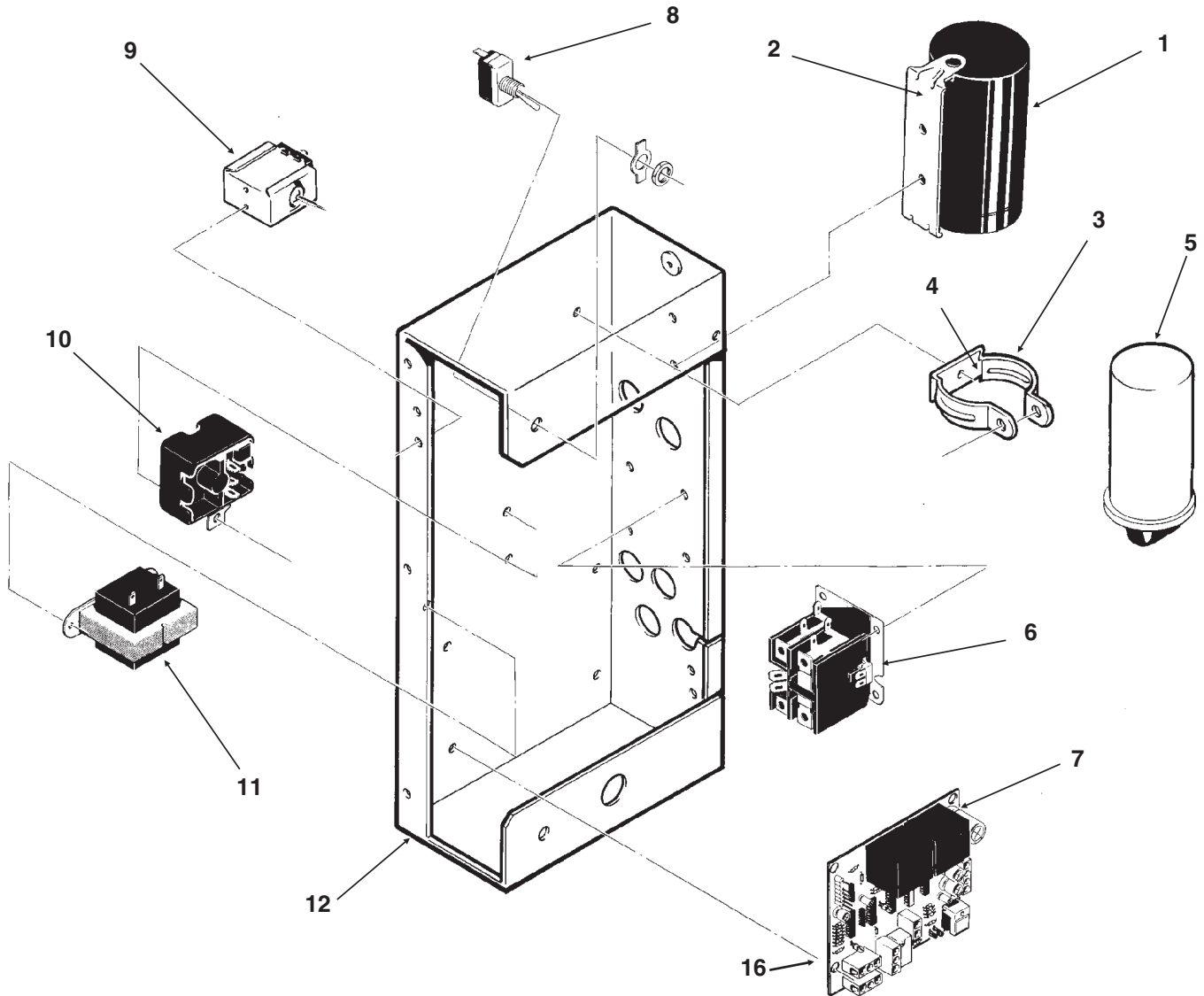

ITEM NUMBER	PART NUMBER	DESCRIPTION	ITEM NUMBER	PART NUMBER	DESCRIPTION
1	18-1901-15	Start Capacitor	7	A37750-021	Circuit Board
	18-2200-38	Start Capacitor Cap.	8.	12-0426-01	Master Switch
2.	18-2200-39	Start Capacitor Bracket	9.	11-0420-23	Pump Down Control
	03-1638-04	Screw	10	18-1903-33	Potential Relay
	03-1417-15	Lockwasher	11.	12-2285-22	Transformer
3.	A32872-001	Run Cap Bracket	12	no number	Control Box Assy
	03-1652-02	Bolt	NOT ILLUSTRATED		
	03-0255-04	Wing Nut	13.	12-2337-02	3 Pin Plug Assy
4.	03-1638-03	Screw			(Safety Circuit to Circuit Board)
5.	18-1902-53	Run Capacitor	14.	12-2340-01	4 Pin Plug Assy
6.	12-2469-02	Single Phase Contactor			(Transformer to Circuit Board)
	12-0739-02	Three Phase Contactor	15.	A34055-001	Control box cover
			16	12-2350-01	Spacer/screw

FM1202R SERVICE PARTS REMOTE CONDENSER

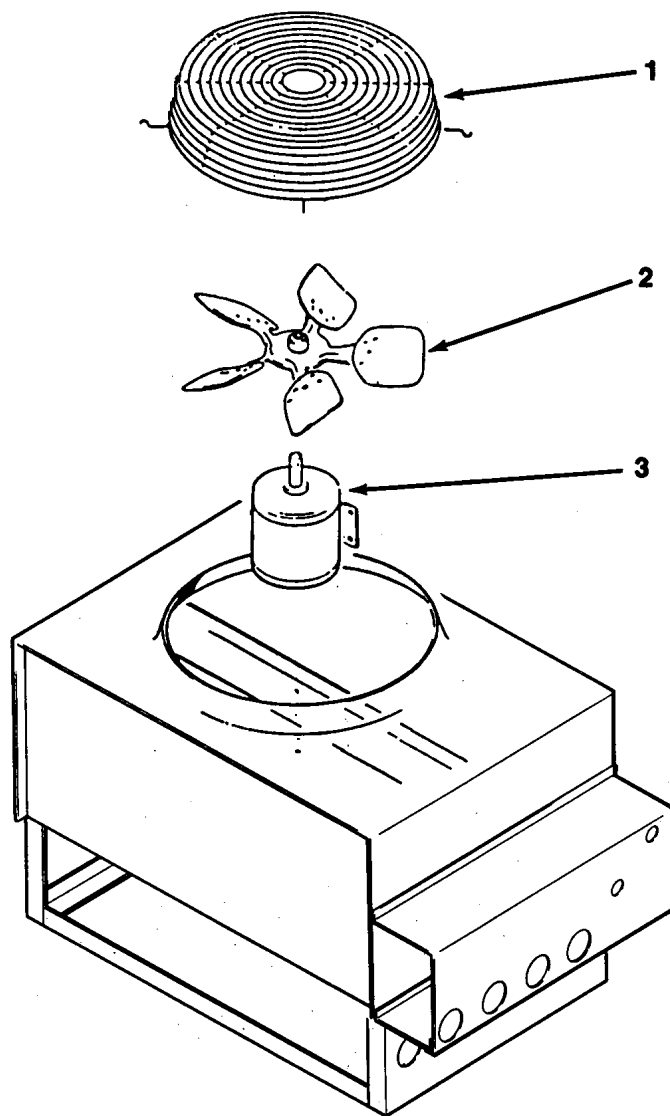

RC1022-32A or RC1222-32A

ITEM NUMBER	PART NUMBER	DESCRIPTION
1.	02-2628-01	Fan Guard
2.	18-6304-01	Fan Blade
3.	18-5301-01	Fan Motor
4.	16-0701-02	Line connection, female half 3/8"
5.	16-0701-10	Line connection, female half 1/2"

FM1202R SERVICE PARTS

Wiring Diagram, 208-230/60/1

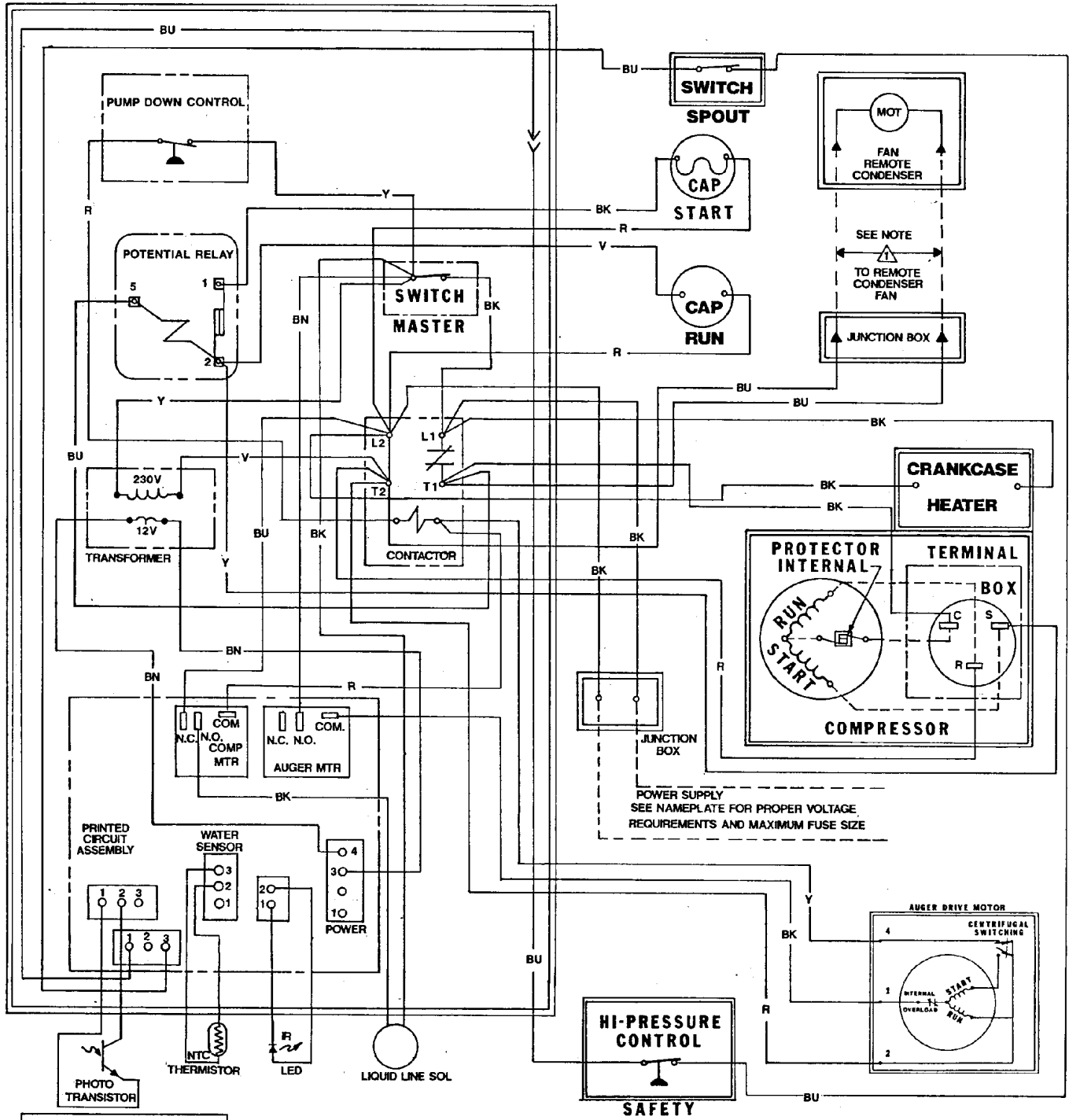

A34492-032

FM1202R SERVICE PARTS

Schematic Diagram, 208-230/60/1

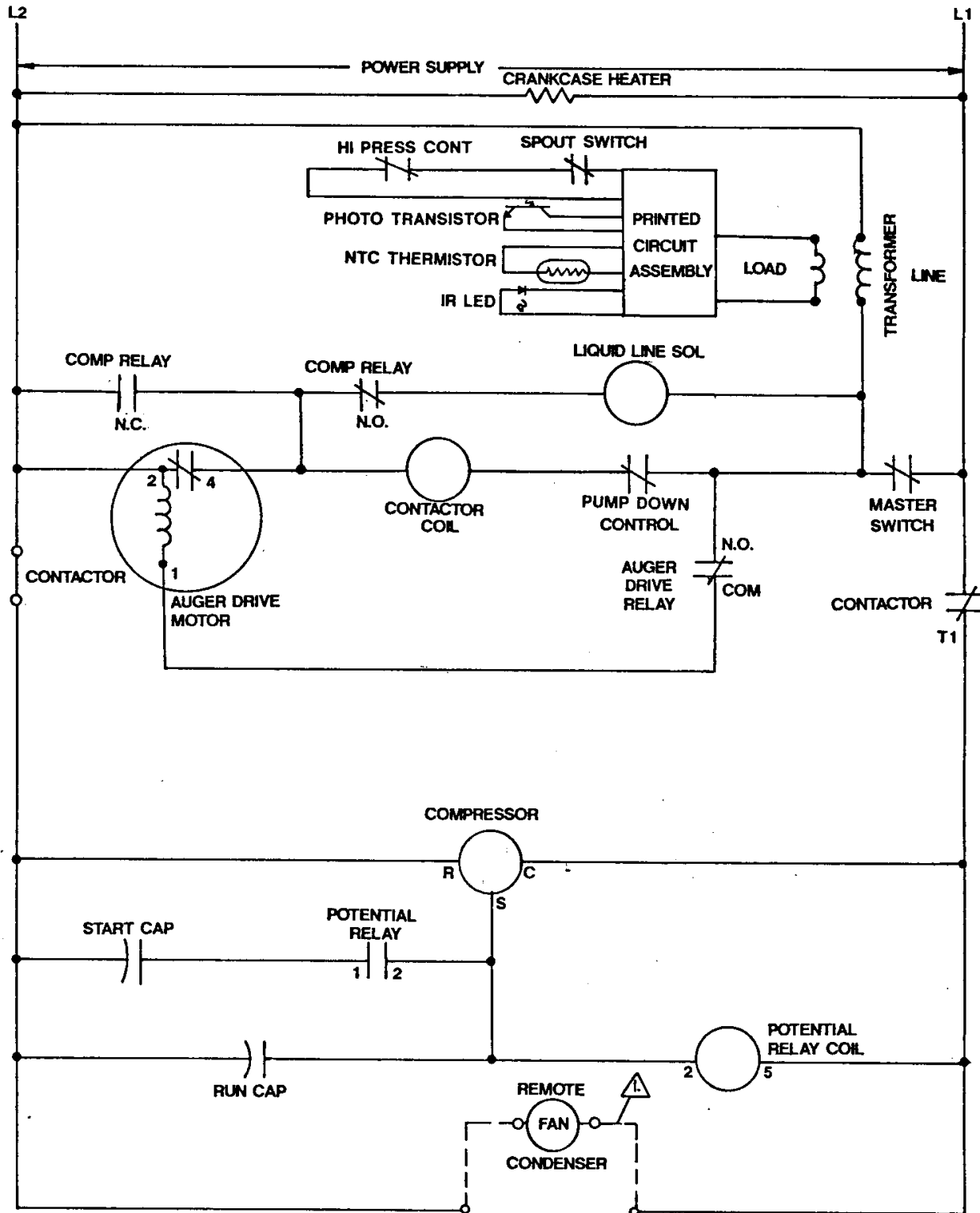

USE COPPER CONDUCTORS ONLY THIS UNIT MUST BE GROUNDED

All Controls Shown in Normal Ice Making Mode.

Note: Dashed lines indicate field wiring which must be installed in accordance with the National Electric Code Using a Minimum of 14 ga. awg. wire.

FM1202R SERVICE PARTS

Wiring Diagram, 208-230/60/3

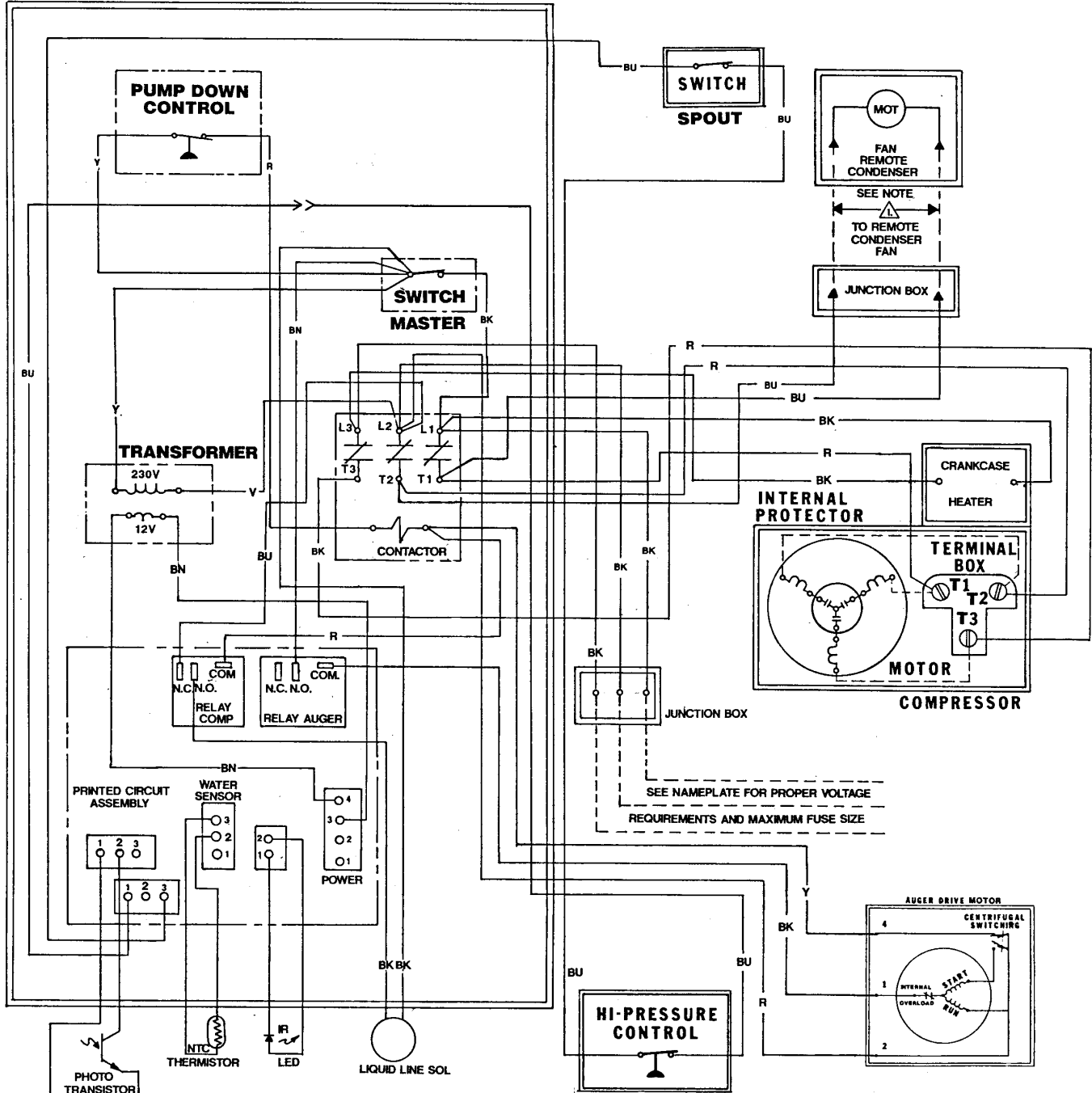

A34492-003

FM1202R SERVICE PARTS

Schematic Diagram, 208-230/60/3

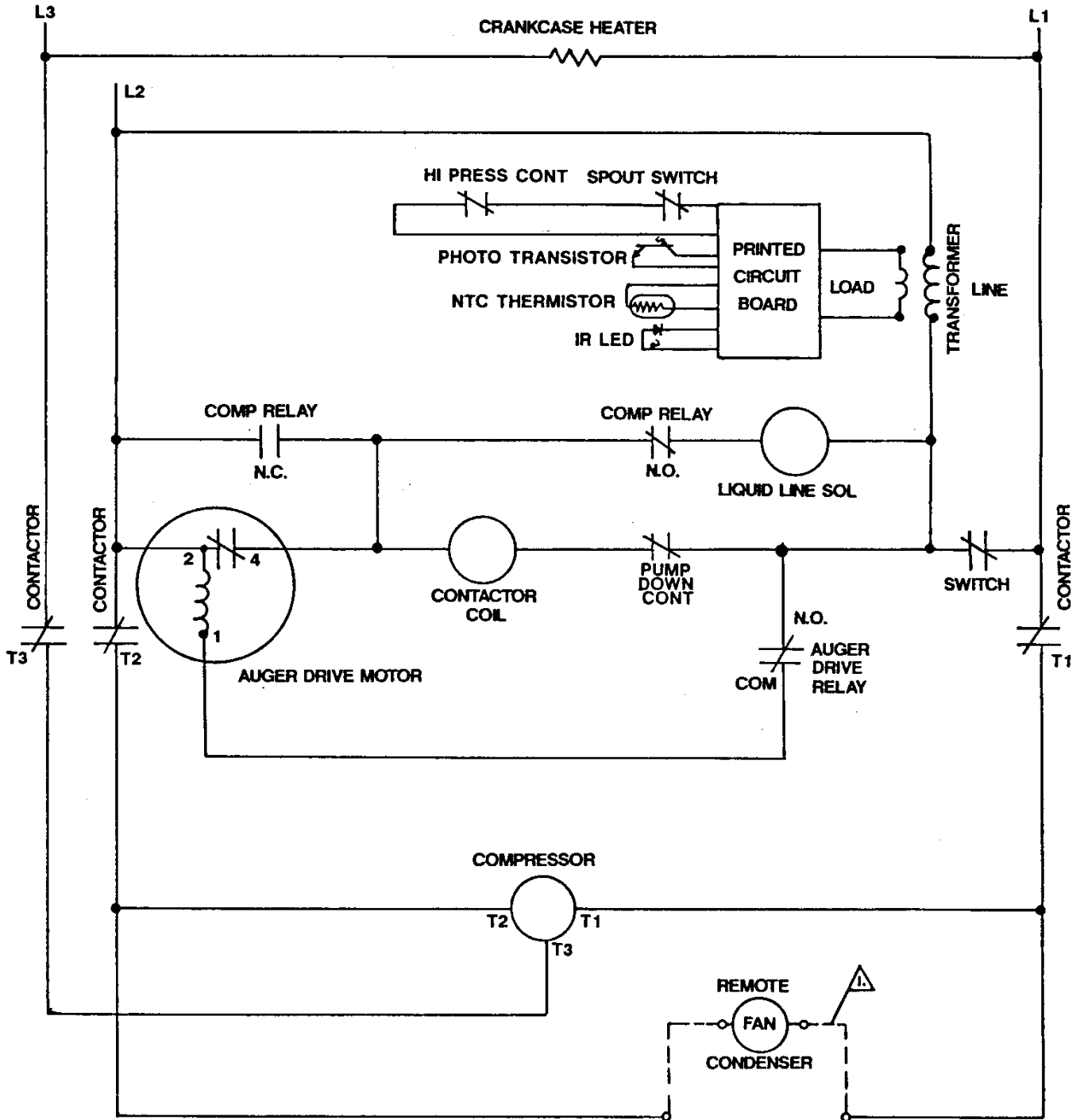

USE COPPER CONDUCTORS ONLY THIS UNIT MUST BE GROUNDED

All Controls Shown in Normal Ice Making Mode.

Note: Dashed lines indicate field wiring which must be installed in accordance with the National Electric Code Using a Minimum of 14 ga. awg. wire.