

LA CIBALI

PARTI DI RICAMBIO
PIECES DETACHEES
SPARE PARTS
ERSATZTEILE
LISTA DE RECAMBIOS

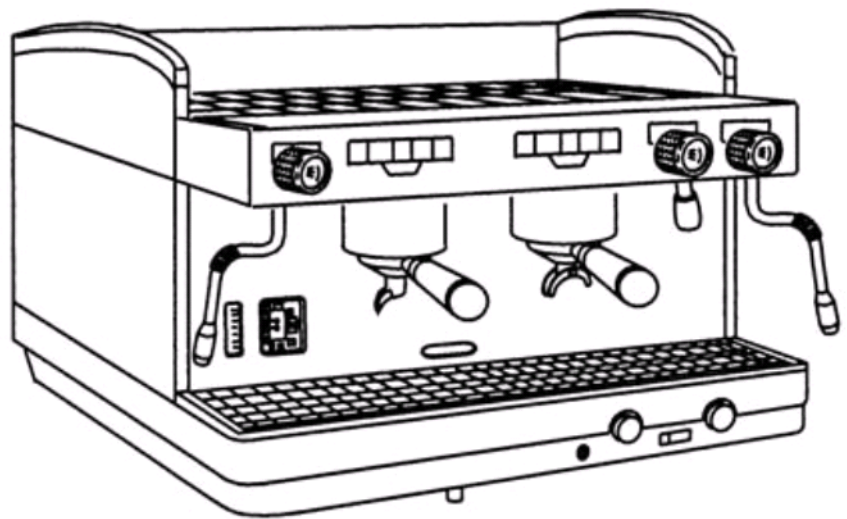

M27 2008 DT

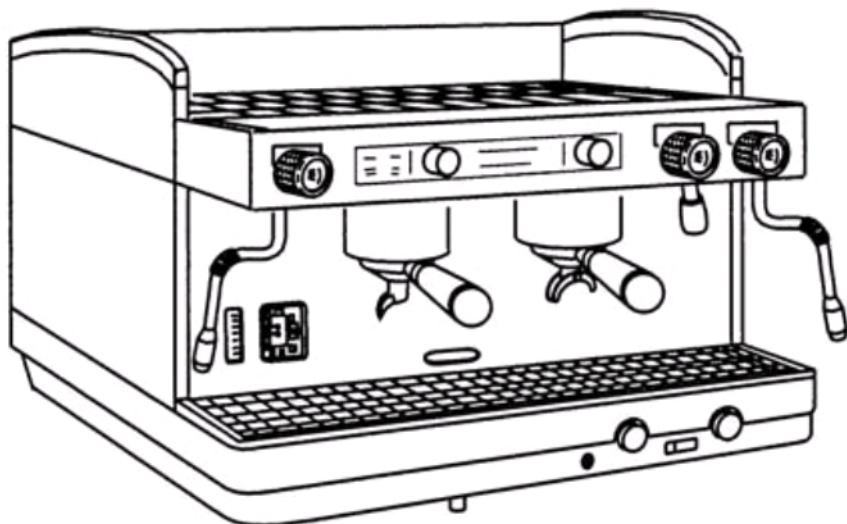

M27 2008 C

TAB.	
1013C-01	CARROZZERIA - CARROSSERIE - COACHWORK - KAROSSERIE - CARROCERIA - ESTRUTURA
1013C-02	CARROZZERIA - CARROSSERIE - COACHWORK - KAROSSERIE - CARROCERIA - ESTRUTURA
1013C-03	PULSANTIERA - PLATINE A BOUTONS - POUSSOIRS - PUSH BUTTON STRIP - TASTATUR - PLACA DA PULSADORES
1013C-04	RUBINETTI - ROBINETES - COCKS - GRIFOS - HAEHNE
1013C-05	TUBAZIONI - TUBES - PIPING - ROHRE - TUBOS - TUBOS
1013C-06	TUBAZIONI - TUBES - PIPING - ROHRE - TUBOS - TUBOS
1013C-07	SCATOLA ELETTRICA - BOITE ELECTRIQUE - SWITCH BOX - SCHALKASTEN CAJA ELECTRICA
1013C-08	VALVOLE CON AUTOLIVELLO - VANNES AVEC ENTREE D'EAU AUTOMATIQUE VALVE WITH SELF LEVEL - VENTIL MIT AUTOM. WASSERSTAND VALVULAS CON AUTONIVEL
1013C-09	ELETTROPOMPA VOLUMETRICA - POMPE VOLUMETRIQUE - VOLUMETRIC PUMP VOLUMETRISCHE PUMPE - ELECTROBOMBA VOLUMETRICA
1013C-10	GRUPPO EROGATORE - GROUPE DEBIT - DELIVER GROUP - BRUHSATZ GROUPO DISTRIBUCION
1013C-11	MANOMETRI - TURBINETTA - MANOMETER - TURBINE
1013C-12	PORTAFILTRO - PORTE-FILTRE - FILTERHOLDER - FILTERHALTER
1013C-13	RESISTENZE - RESISTANCES - HEATING ELEMENTS - HEIZELEMENTE - RESISTENCIAS
1013C-14	CALDAIA - CHAUDIERE - BOILER - KESSEL - CALDERA

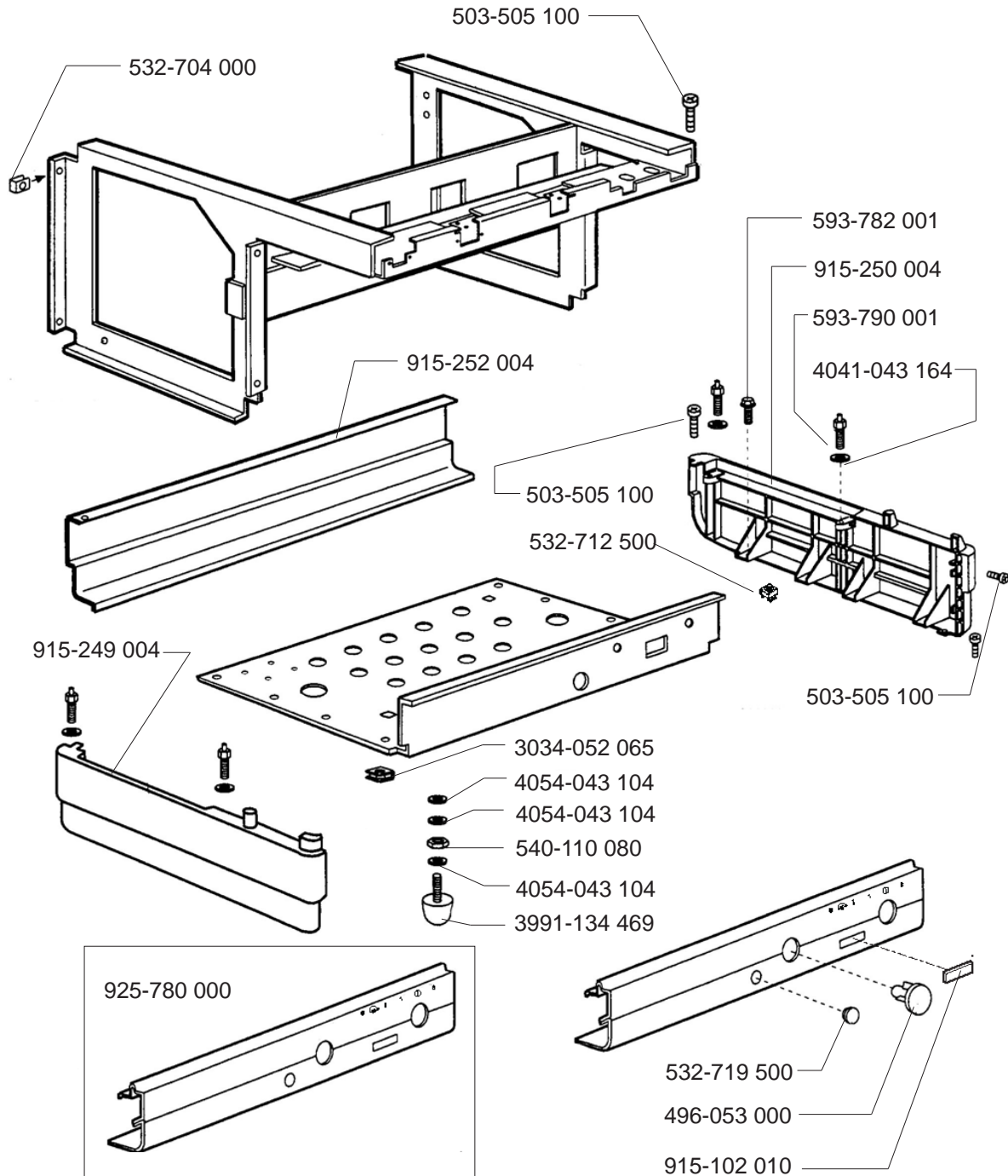

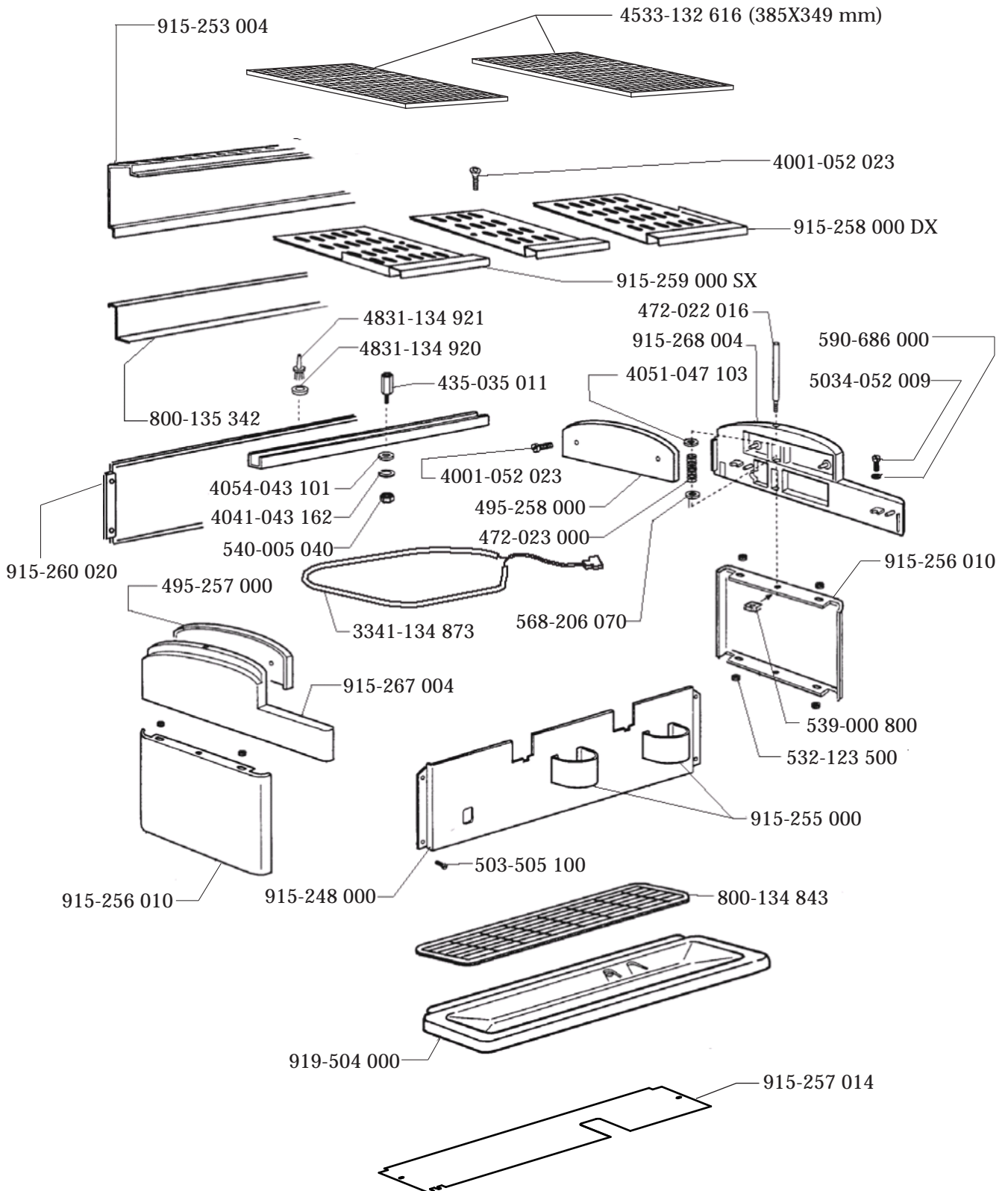

M27 2008 C

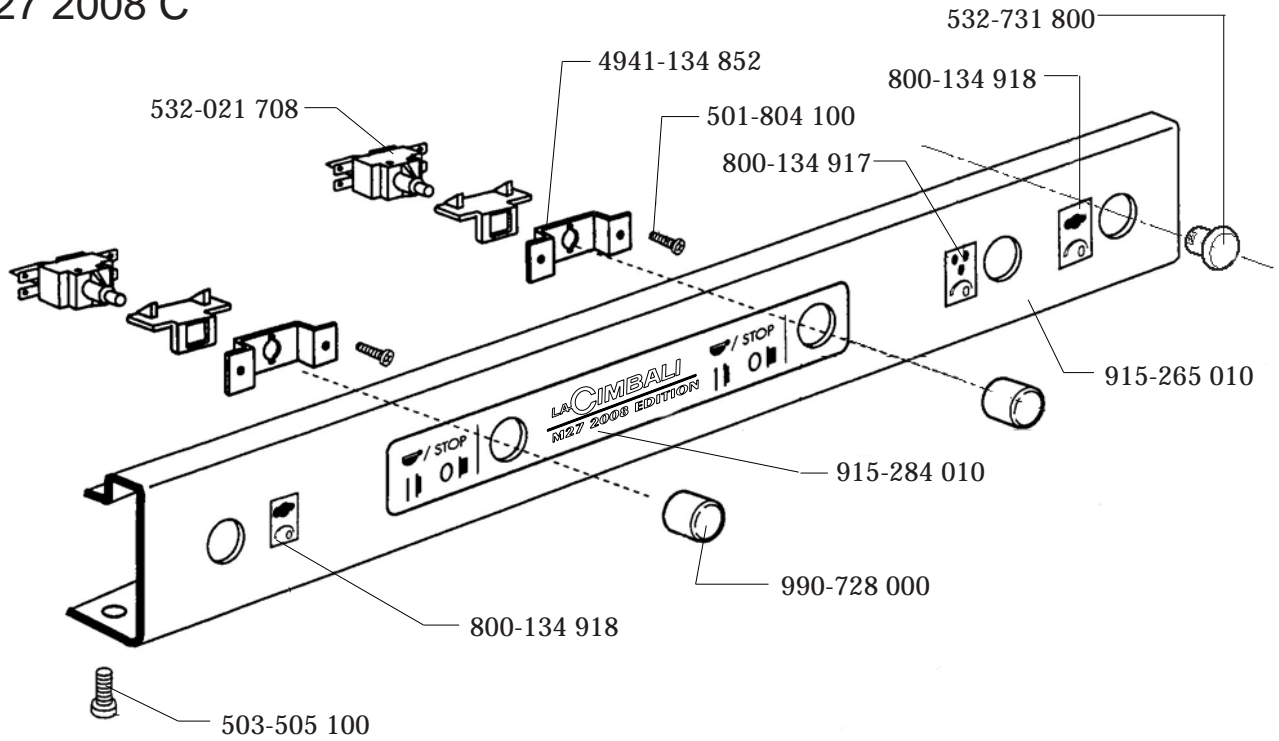

M27 2008 DT

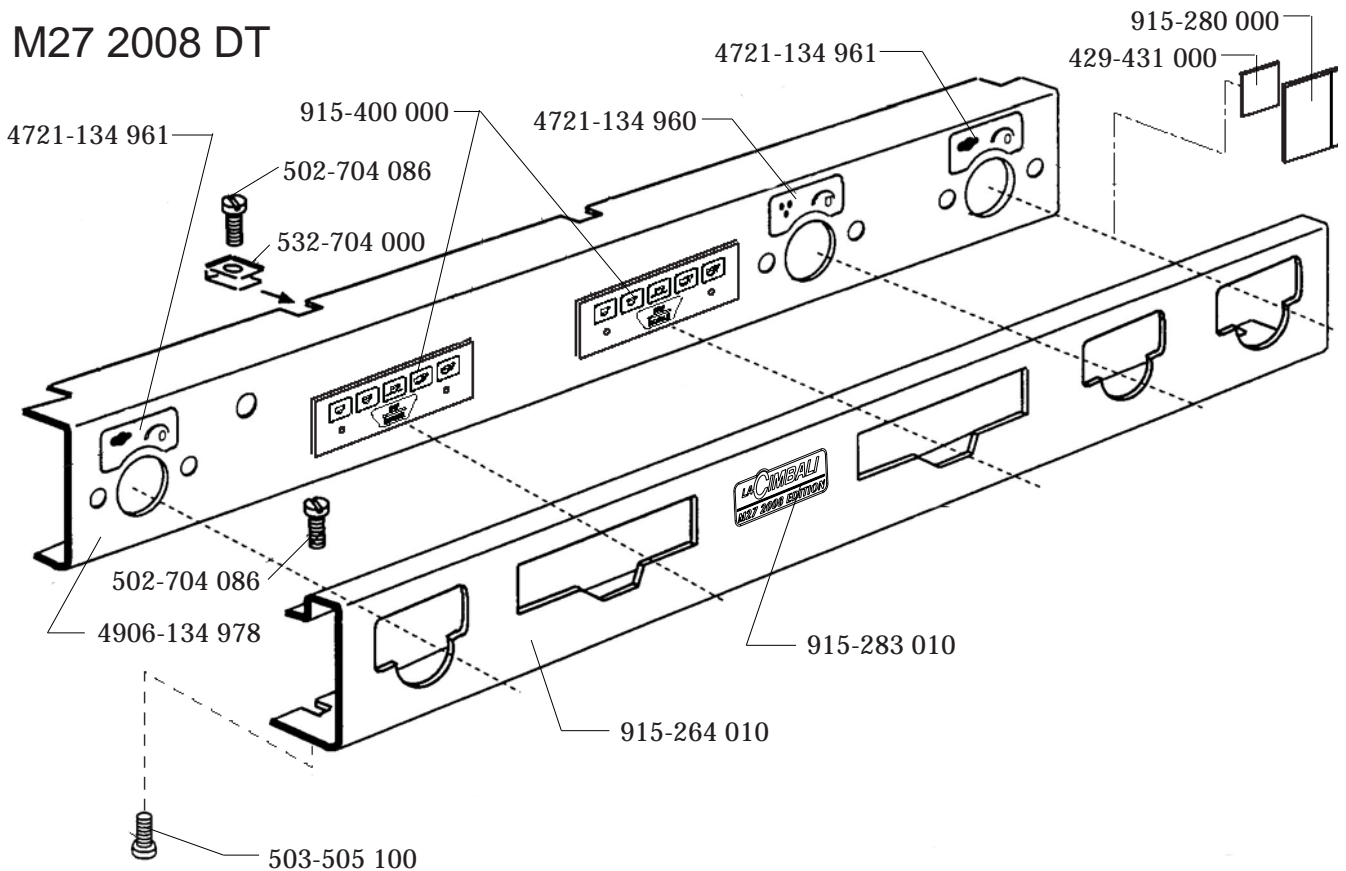

Valido dalla matricola n.°
 Valable à partir du matricule n.°
 Valid from No. - Gültig ab der Abkenn.-Nr. - Valido a partir de la matricula n.°

11 - 08

1013C-03

* Particolare nuovo o modificato - *Pièce nouvelle ou modifiée* - New or modified part
Neues oder geändertes Teil - Particular nuevo o modificado

TAB.

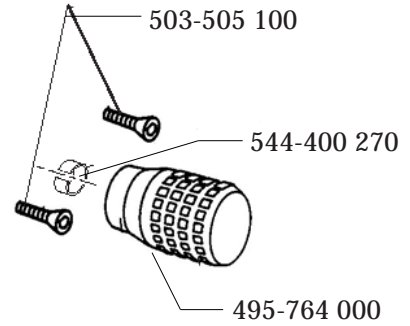
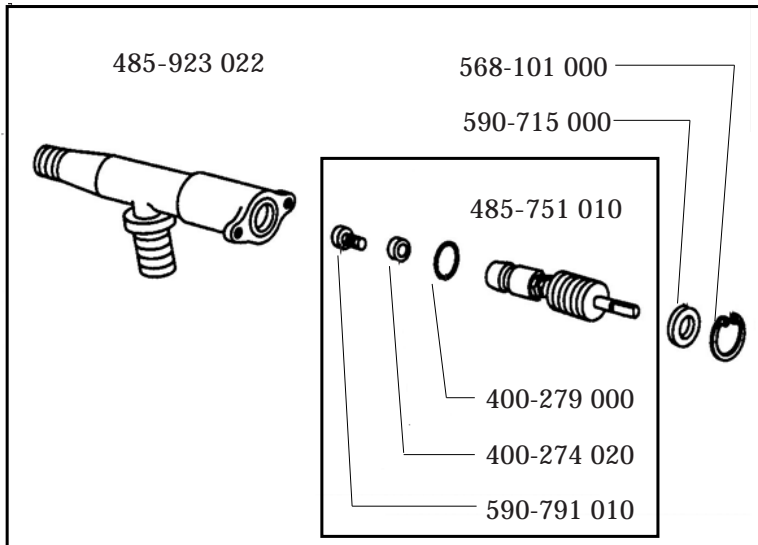

VAPORE / STEAM
2221-135 023

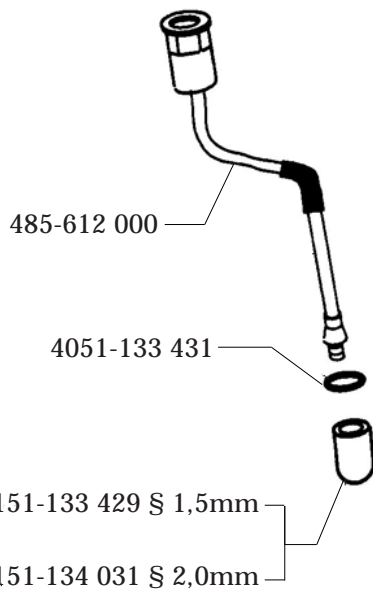
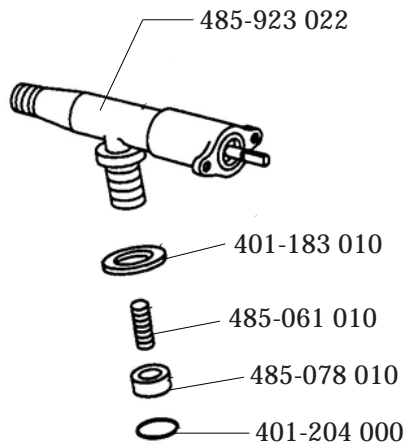

ACQUA / WATER
2221-134 925

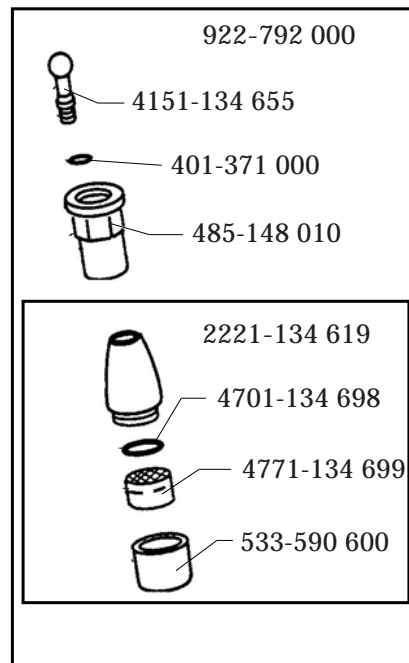
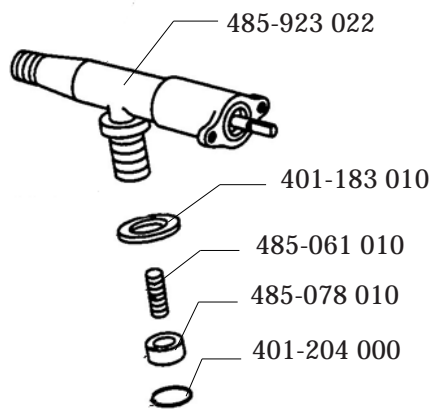

TUBAZIONI - TUBES - PIPING
ROHRE - TUBOS - TUBOS

M27 2008 DT

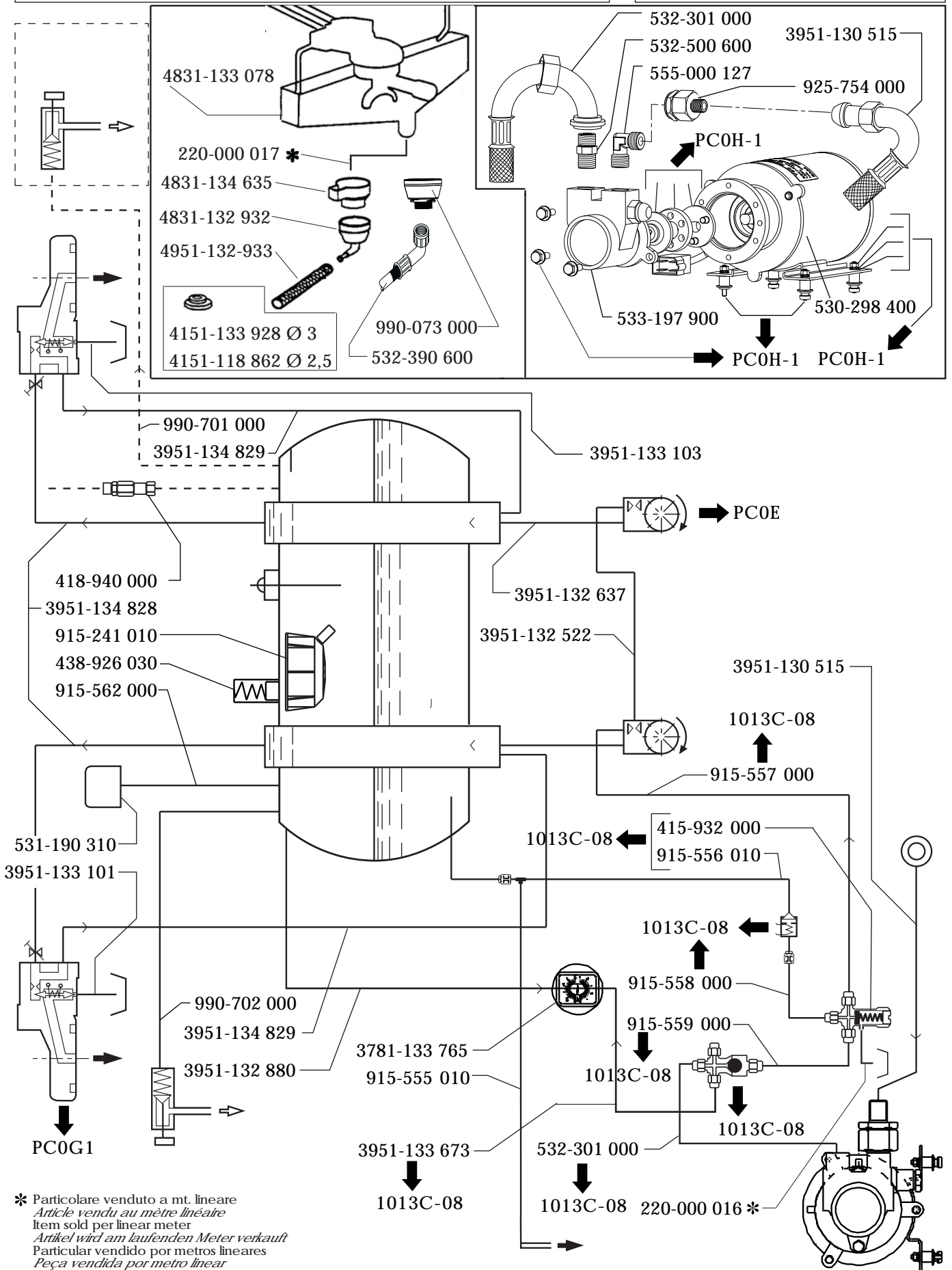

* Particolare venduto a mt. lineare
Article vendu au mètre linéaire
Item sold per linear meter
Artikel wird am laufenden Meter verkauft
Particular vendido por metros lineares
Peça vendida por metro linear



Valido dalla matricola n.° _____
Valable à partir du matricule n.° _____
Valid from No. - Gültig ab der Abkenn.-Nr. - Valido a partir de la matricula n.° _____

* Particolare nuovo o modificato - Pièce nouvelle ou modifiée - New or modified part
Neues oder geändertes Teil - Particular nuevo o modificado

11-08

Edizione del
Edition du
Edition of
Ausgabe vom
Edición del

1013C-05

TAB.

TUBAZIONI - TUBES - PIPING
ROHRE - TUBOS - TUBOS

M27 2008 C

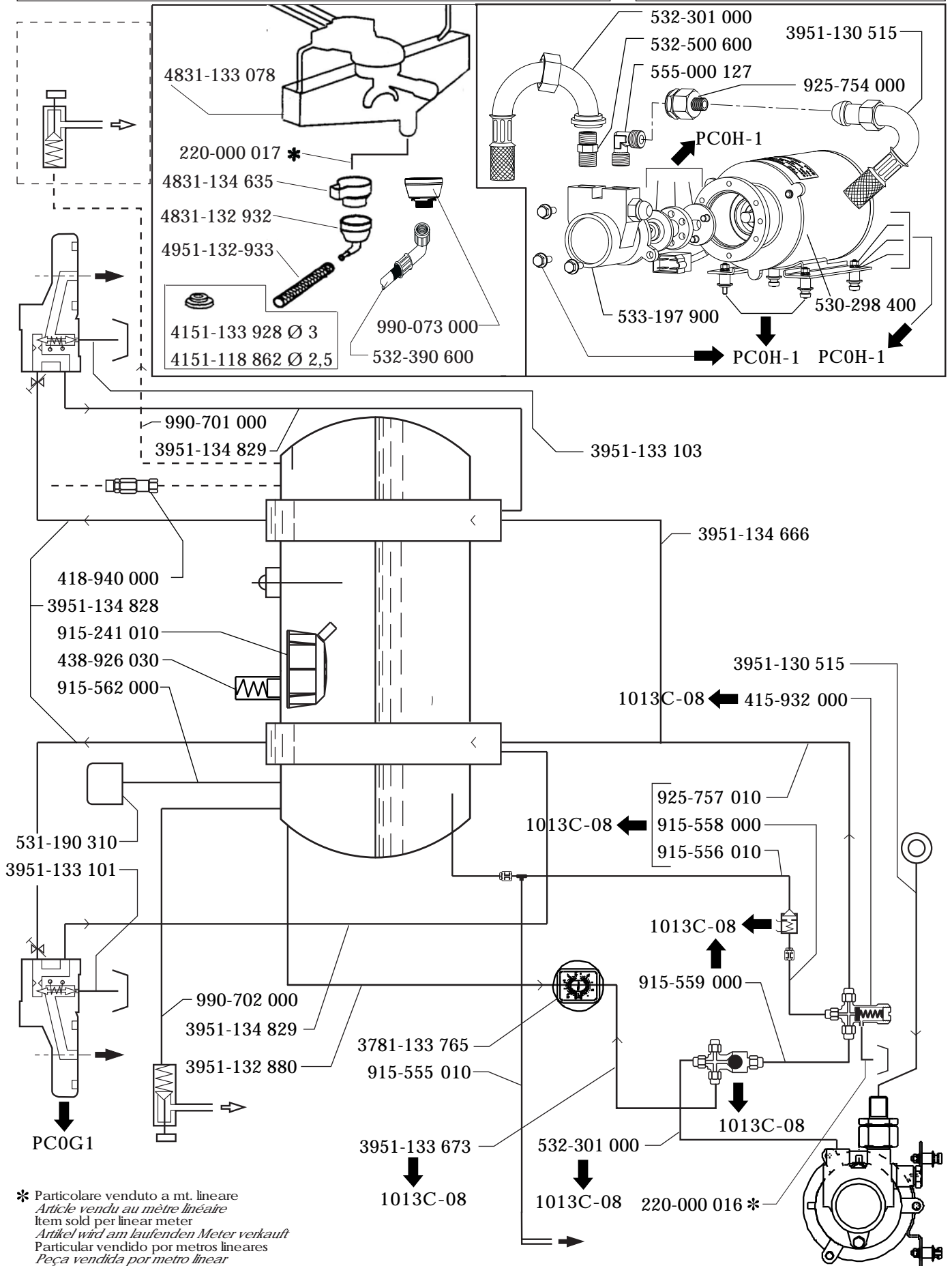

* Particolare venduto a mt. lineare
Article vendu au mètre linéaire
Item sold per linear meter
Artikel wird am laufenden Meter verkauft
Particular vendido por metros lineares
Peça vendida por metro linear

LA CIMALI

Valido dalla matricola n.°
Valable à partir du matricule n.°
Valid from No. - Gültig ab der Abkenn.-Nr. - Valido a partir de la matricula n.°

* Particolare nuovo o modificato - *Pièce nouvelle ou modifiée* - New or modified part
Neues oder geändertes Teil - Particular nuevo o modificado

11-08

Edizione del
Edition du
Edition of
Ausgabe vom
Edición del

1013C-06

TAB.

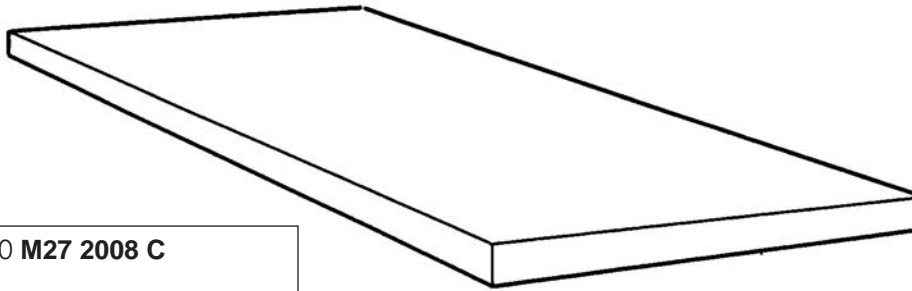

925-752 000 **M27 2008 C**

925-751 000 **M27 2008 DT**

Cablaggio generale
Complete electrical wire

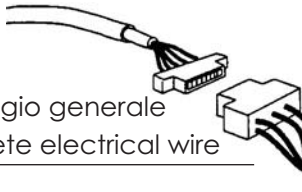

3301-135 353

M27 2008 C/DT

Cablaggio scatola elettrica
Electrical box wire

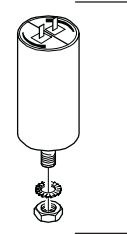

2341-119 567

918-910 008 **M27 2008 DT**

535-514 008 **M27 2008 C**

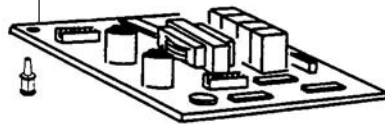

3501-117 396 **Fuse F4A**

3501-117 399 **Fuse T 0,1A**

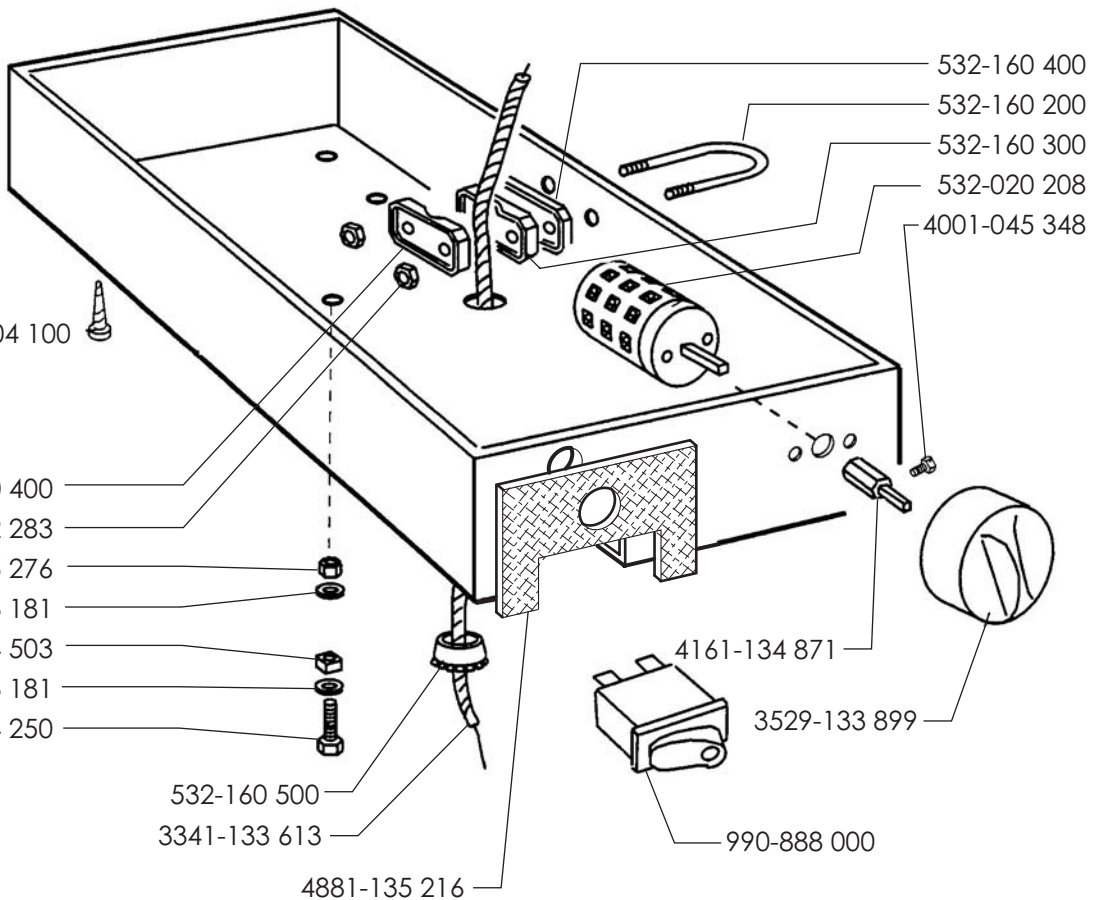

501-804 100

532-160 400

4031-052 283

4031-045 276

4041-043 181

4031-134 503

4041-043 181

502-604 250

532-160 500

3341-133 613

4881-135 216

532-160 400

532-160 200

532-160 300

532-020 208

4001-045 348

4161-134 871

3529-133 899

990-888 000

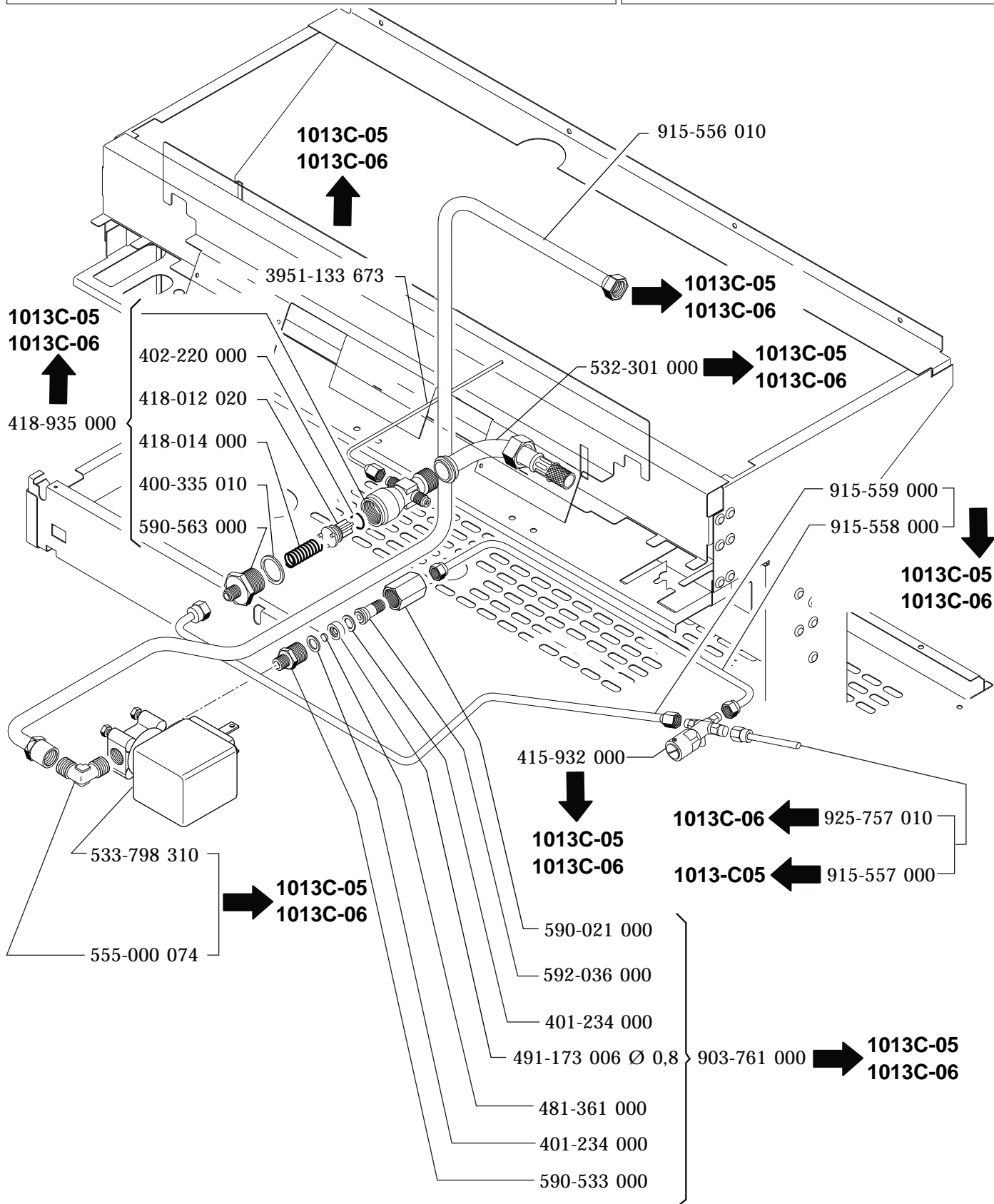

Valido dalla matricola n.°
 Valable à partir du matricule n.°
 Valid from No. - Gültig ab der Abkenn.-Nr. - Valido a partir de la matricula n.°

11 - 08

1013C-08

* Particolare nuovo o modificato - Pièce nouvelle ou modifiée - New or modified part
 Neues oder geändertes Teil - Particular nuevo o modificado

Edizione del
 Edition du
 Edition of
 Ausgabe vom
 Edición del

TAB.

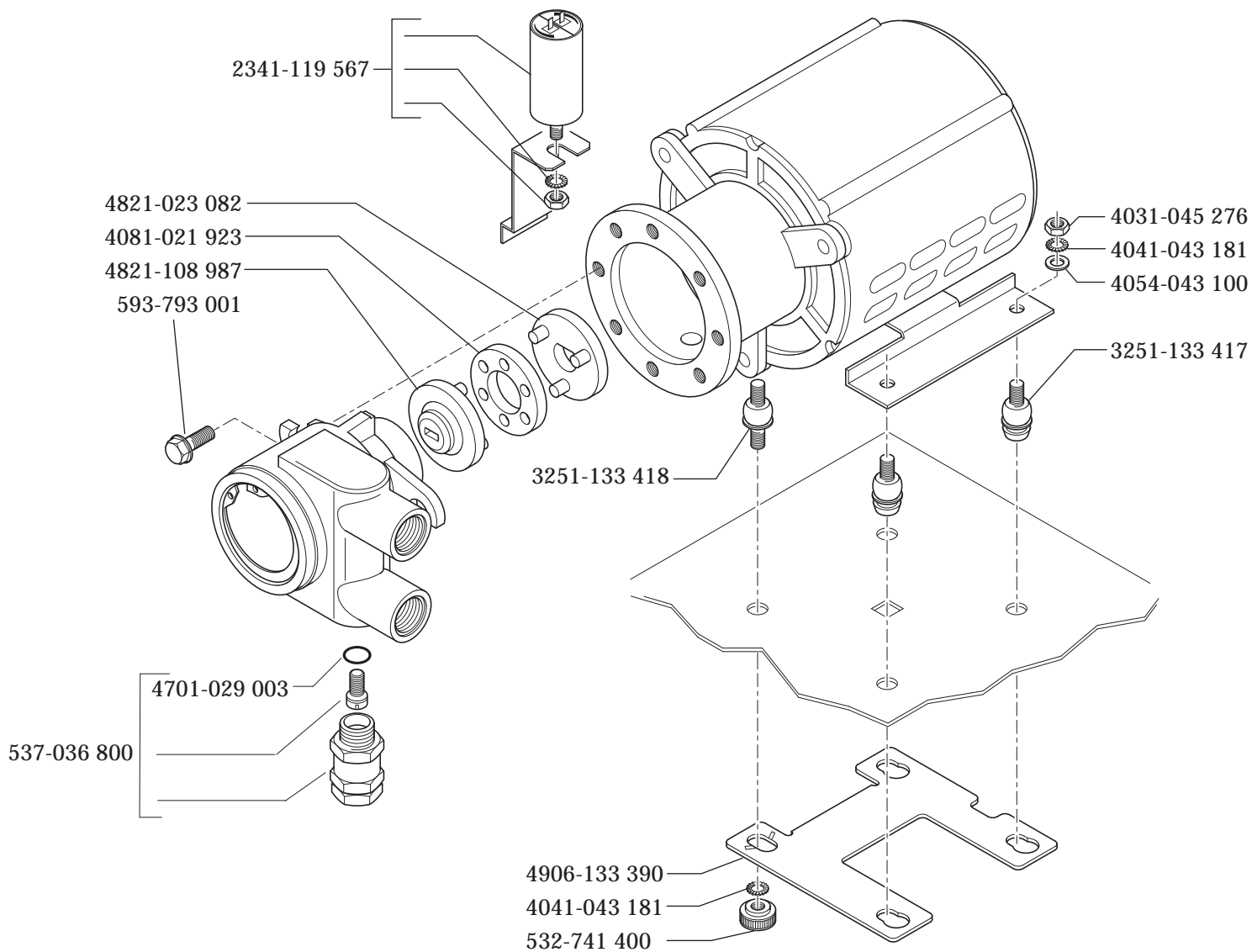

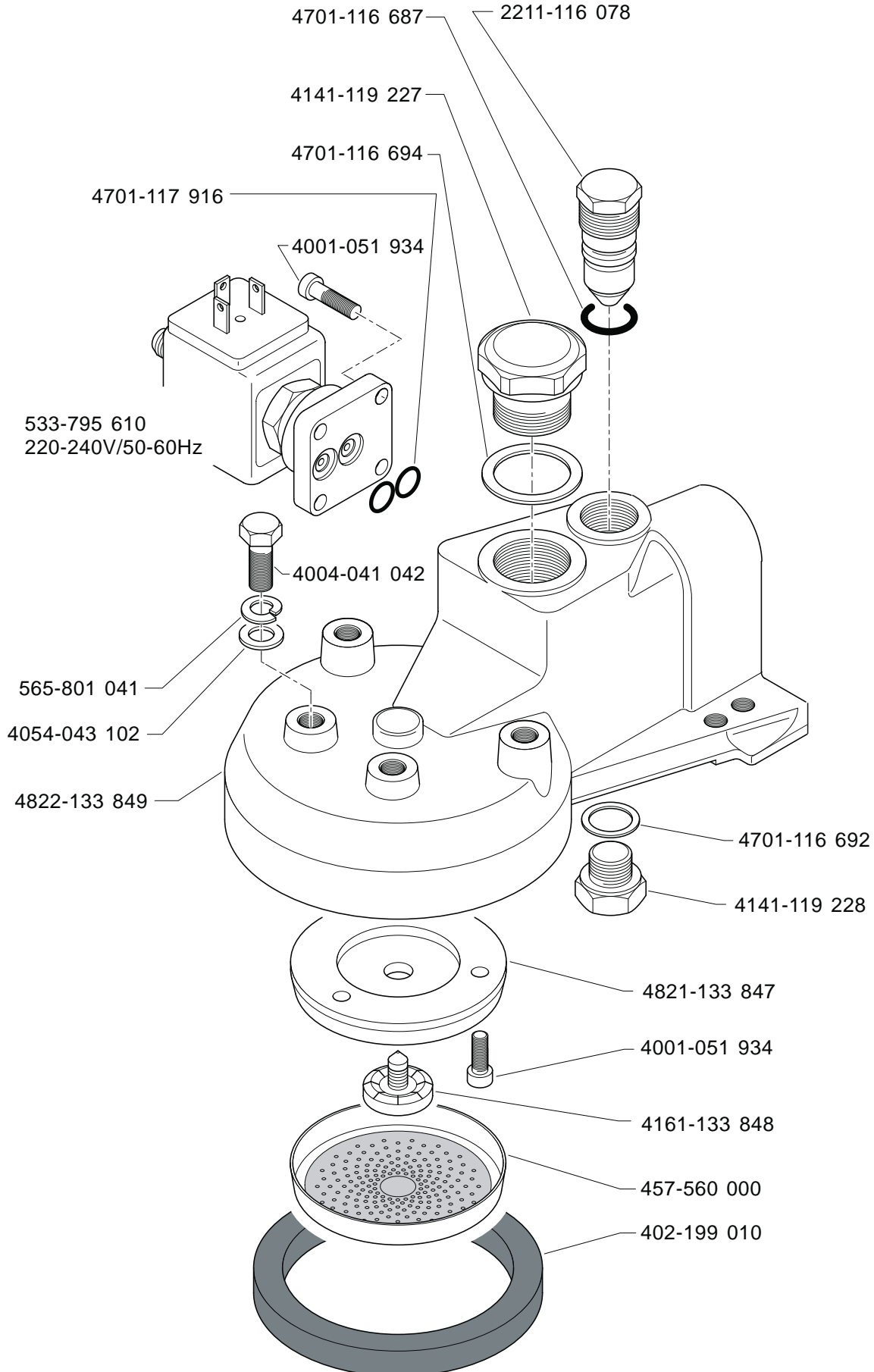

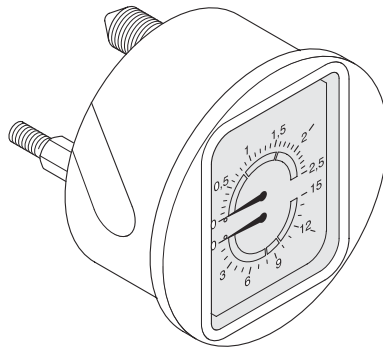

3781-133 765

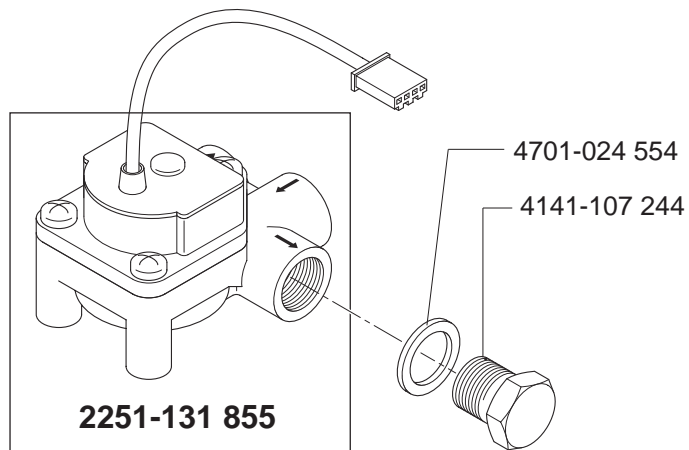

2251-131 855

4701-024 554

4141-107 244

