

GAS-KOCHKESSEL

700 - Reihe

TYP: 7NP/G50, 7NP/GI50

Ersatzteile



9. Ersatzteile

Aussenteile.....55

Innenteile.....57

9.1 Spannungscodes

Spannung	Spannungscodes
A	3/N/PE~400/230V 50Hz
B	~250V 16A 50Hz
C	3/N/PE~380/220V 50Hz
D	3/PE~200V 50-60Hz
F	2/PE 220-240V 50Hz
G	3/N/PE~415/240V 50Hz
H	3/PE~230V 50Hz
I	3/PE~220V 60Hz
J	3/PE~380 50Hz
K	3/PE~400V 50Hz
L	3/PE~415V 50Hz
M	3/PE~440V 60Hz
N	3/PE~460V 60Hz
O	3/PE~480V 60Hz
P	1/N/PE~220-240V 50Hz
R	2/PE~220-230V 60Hz
S	3/N/PE~400/230V 50Hz
T	3/PE~230V 60Hz
U	1/N/PE~100V 50-60Hz

9.2 Produktcodes

Produktcode	Ernennung
Typecodes	
74GD	7NP/G50
74GI	7NP/GI50

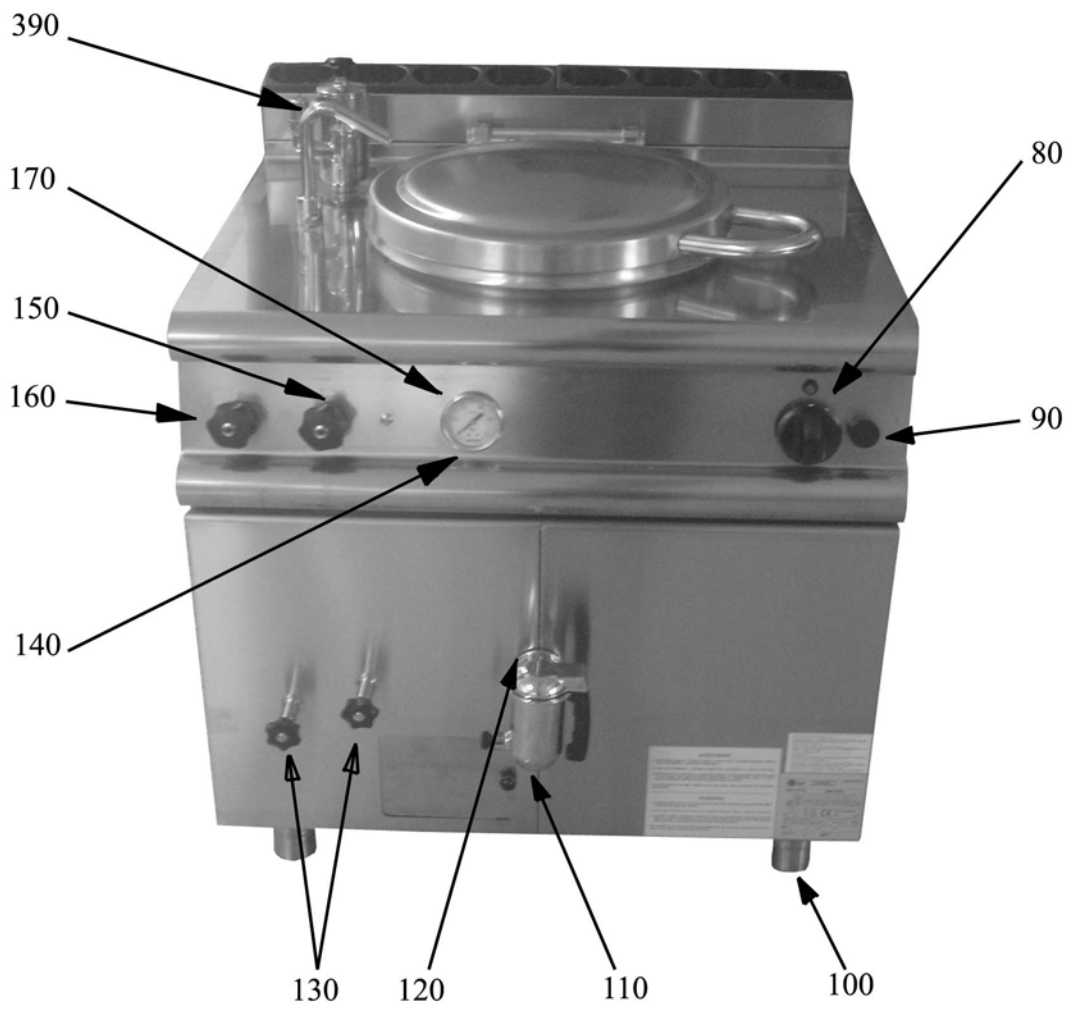
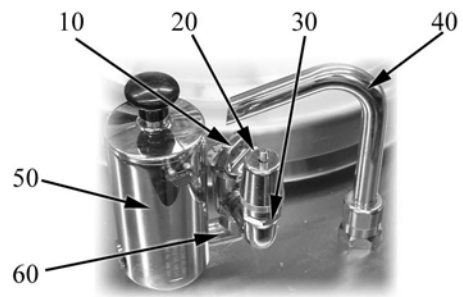

ID	Typ	Spannung	Description	P-code
Module:Aussenteile				
10	74GI		Stopfen Ausgleichsbehälter	6A022235
20	74GI		Unterdruckventil	6A022231
30	74GI		Scheibe f. Unterdruckventil	6A022232
40	74GI		Zufuhrelement	6A022240
50	74GI		Sicherheitsgruppe	6A022230
60	74GI		gabelförmiger Ausgleichsbehälter	6A022233
80			Knebel	824710100
90			Piezozündung	6A041105
100			Fuss	2519500
110			Ablasshahn	6A021050
120			Aussendichtung	6A022280
130	74GI		Wasserstandhahn	6A022250
140	74GI		Manometerrohr	2515117
150			Knebel	6A022453
160			Knebel	6A022456
170	74GI		Manometer	6A022210
390	74GI		Zusammenschluss Sicherheitseinheit	2591677

74GD=7NP/G50, 74G=7NP/G150

A=3/N/PE~400/230V 50Hz

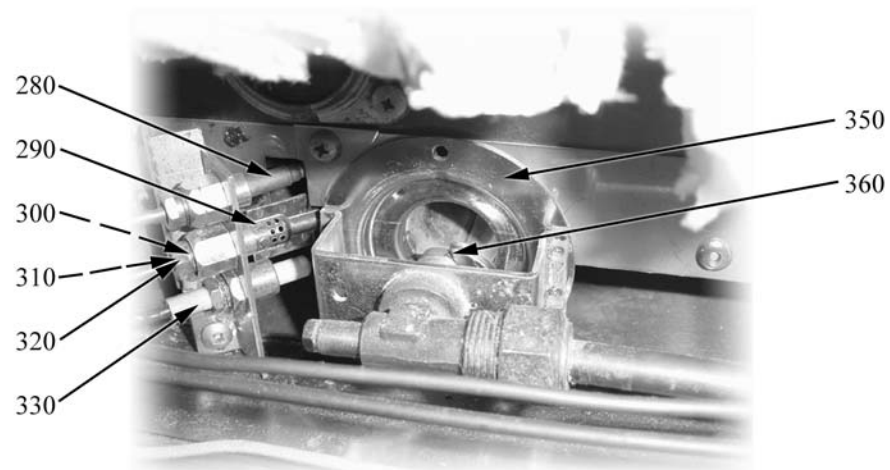
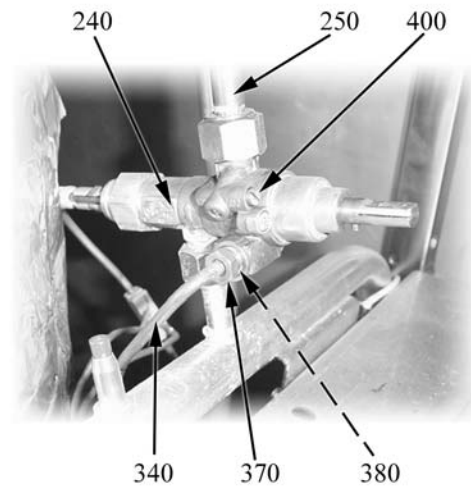
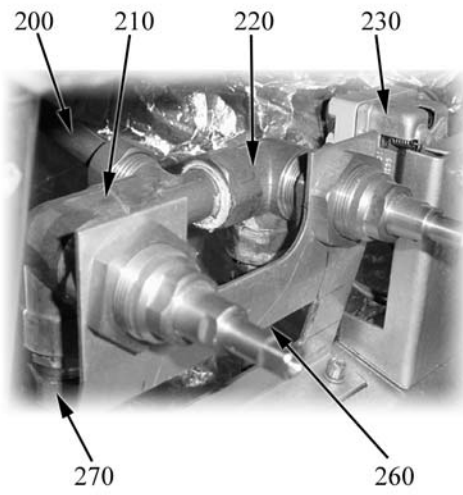
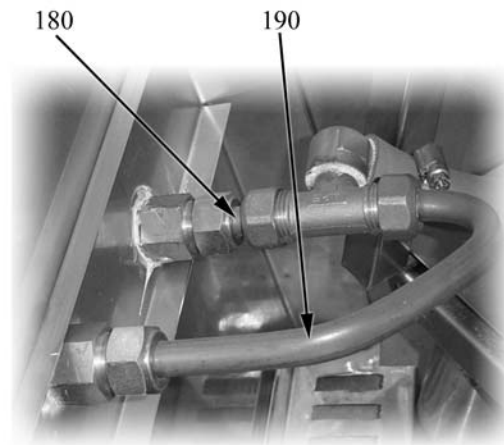

ID	Typ	Spannung	Description	P-code
Module:Innenteile				
180	74GI		Rohr	2515105
190	74GI		Rohr	2515106
200			Rohr	2515102
210			Wassereinlaufhahn, links	6A022412
220			Wassereinlaufhahn, rechts	6A022411
230	74GI		Sicherheitsthermostat	6A049405
240			Hahn	6A011490
250	74GI		Rohr	2515114
250	74GD		Rohr	2515116
260			Rohr	2515101
270			Rohr	2515100
280	74GI		Thermoelement	6A011910
280	74GD		Thermoelement	6A011900
290			Zundflammenbrenner	6A013220
300			Duse 16·2	6A013240
300			Duse 27·2	6A013230
300			Duse 38R	2510332
310			Doppelkegelring	6A016900
320			Überwurfmutter	6A017000
330			Kerze	6A013302
340	74GI		Rohr	2515113
340	74GD		Rohr	2515115
350			Brenner	2519410
360			IT- Dusensatz für Brenner	2591665
			Duse L 185	
			Duse L 280	
			Duse L 295	
			Duse 16·2	
			Duse 27·2	
			By pass	

74GD=7NP/G50, 74G=7NP/G150

A=3/N/PE~400/230V 50Hz

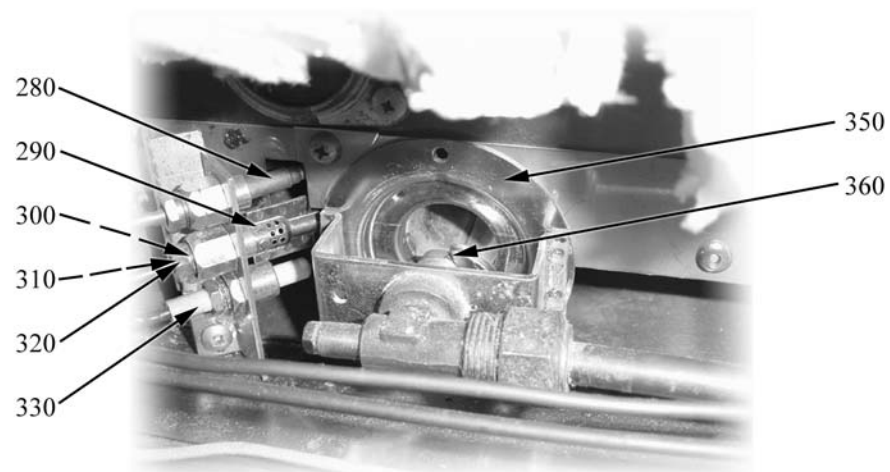
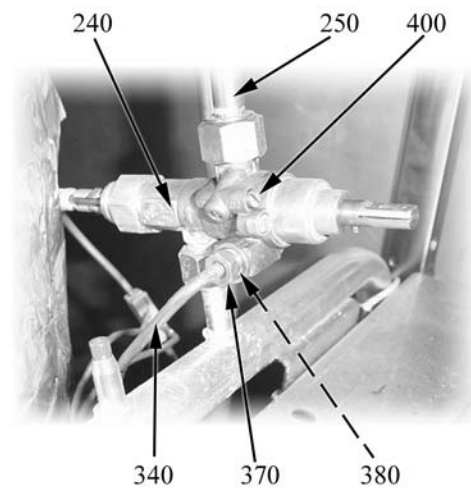
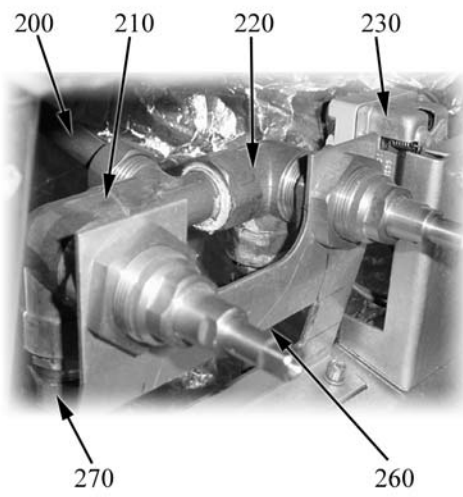
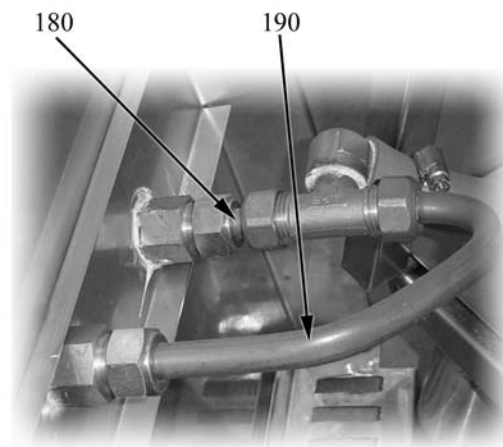

ID	Typ	Spannung	Description	P-code
Module:Innenteile				
360			DE- Dusensatz für Brenner	2591666
			Duse L 160	
			Duse L 280	
			Duse L 295	
			Duse 16·2	
			Duse 27·2	
			By pass	
360			H- Dusensatz für Brenner	2591667
			Duse L 185	
			Duse L 260	
			Duse L 295	
			Duse 16·2	
			Duse 27·2	
			By pass	
370			Überwurfmutter	6A016110
380			Doppelkegelring	6A016120
400			By pass	6A023726

74GD=7NP/G50, 74G=7NP/G150

A=3/N/PE~400/230V 50Hz

