

AFE325 Service Parts

This parts lists contains part numbers for the service parts available for the AFE325.

The AFE325 has been manufactured in both 60 Hz and 50 Hz models.

The 60 Hz models are:

- AFE325AE-1A or AFE325AS-1A
- AFE325AS-1B

The 50 Hz models are:

- AFE325AE-6A or AFE325AS-6A
- AFE325AS-6B

Always check the model number of the ice machine being serviced to be certain that the parts ordered will be correct.

Table of Contents

Cabinet	Page 2
Major Parts	Page 4
Evaporator, Auger, Bearings & Water Seal	Page 6
Spout	Page 7
Gear Reducer and Motor	Page 8
Control Box	Page 9
Wiring Diagrams	Page 10

AFE325 Service Parts Cabinet

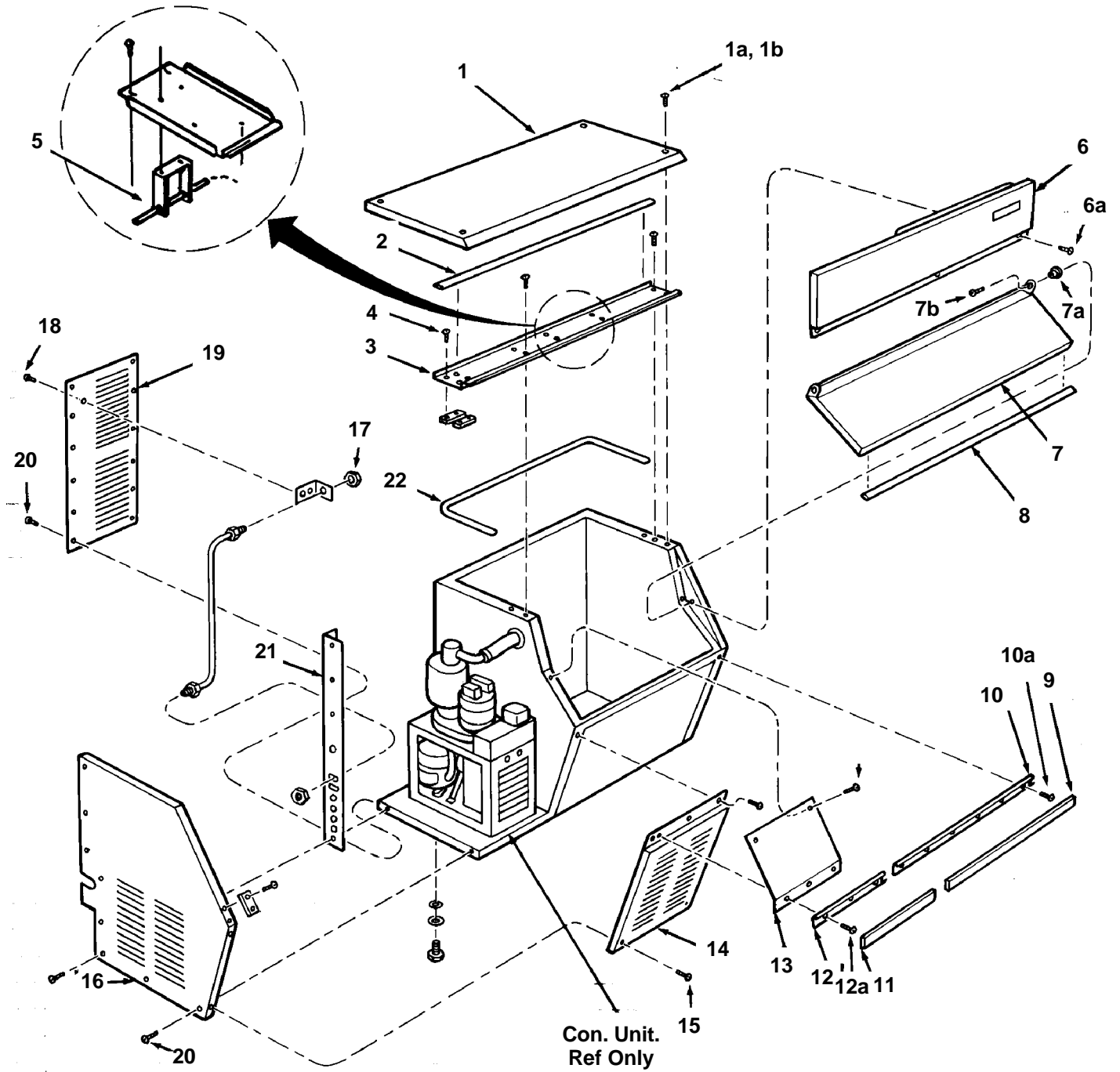

AFE325 Service Parts

Cabinet

Item Number	Part Number	Description
1	A26931-005	Top panel, sandalwood
	A26931-015	Top panel, gray
	A26931-004	Top panel, stainless steel
1a	03-1417-24	Lockwasher
1b	03-1419-23	Screw
2	13-0781-01	Gasket, 34" needed. Order by the foot
3	A34011-001	Top brace
4	03-1404-12	Screw
5	A30720-001	Bin thermostat bracket
6	A26935-005	Upper front panel, sandalwood
	A26935-015	Upper front panel, gray
	A26935-003	Upper front panel, stainless steel
6a	03-1404-10	Screw
7	02-2332-04	Door for sandalwood models (only gray is available)
	02-2332-04	Door for gray painted models
	02-2332-04	Gray door for stainless models (gasket not included with door)
7a	02-2380-01	Hinge bushing
7b	03-1405-07	Screw
8	13-0781-01	Gasket, 33" needed. Order by the foot
9	15-0619-01	Moulding cover
10	15-0617-01	Track section
10a	03-1404-07	Screw
11	15-0618-01	Moulding cover.
12	15-0616-01	Track section
13	A26921-004	Machine compartment baffle, sandalwood
	A26921-015	Machine compartment baffle, gray
	A26921-004	Machine compartment baffle, stainless steel
14	A26928-005	Lower left panel, sandalwood
	A26928-015	Lower left panel, gray
	A26928-004	Lower left panel, stainless steel
15	03-1419-09	Screw
16	A28795-004	Left side panel, sandalwood
	A28795-015	Left side panel, gray
	A28795-002	Left side panel, stainless steel
17	03-1394-01	Pal nut
18	03-1638-03	Screw
19	A34010-001	Rear panel
20	03-1404-09	Screw
21	A27066-003	Corner post, sandalwood
	A27066-015	Corner post, gray
	A27066-002	Corner post, stainless steel
22	13-0781-01	Gasket, 41" needed. Order by the foot.

AFE325 Service Parts

Major Parts

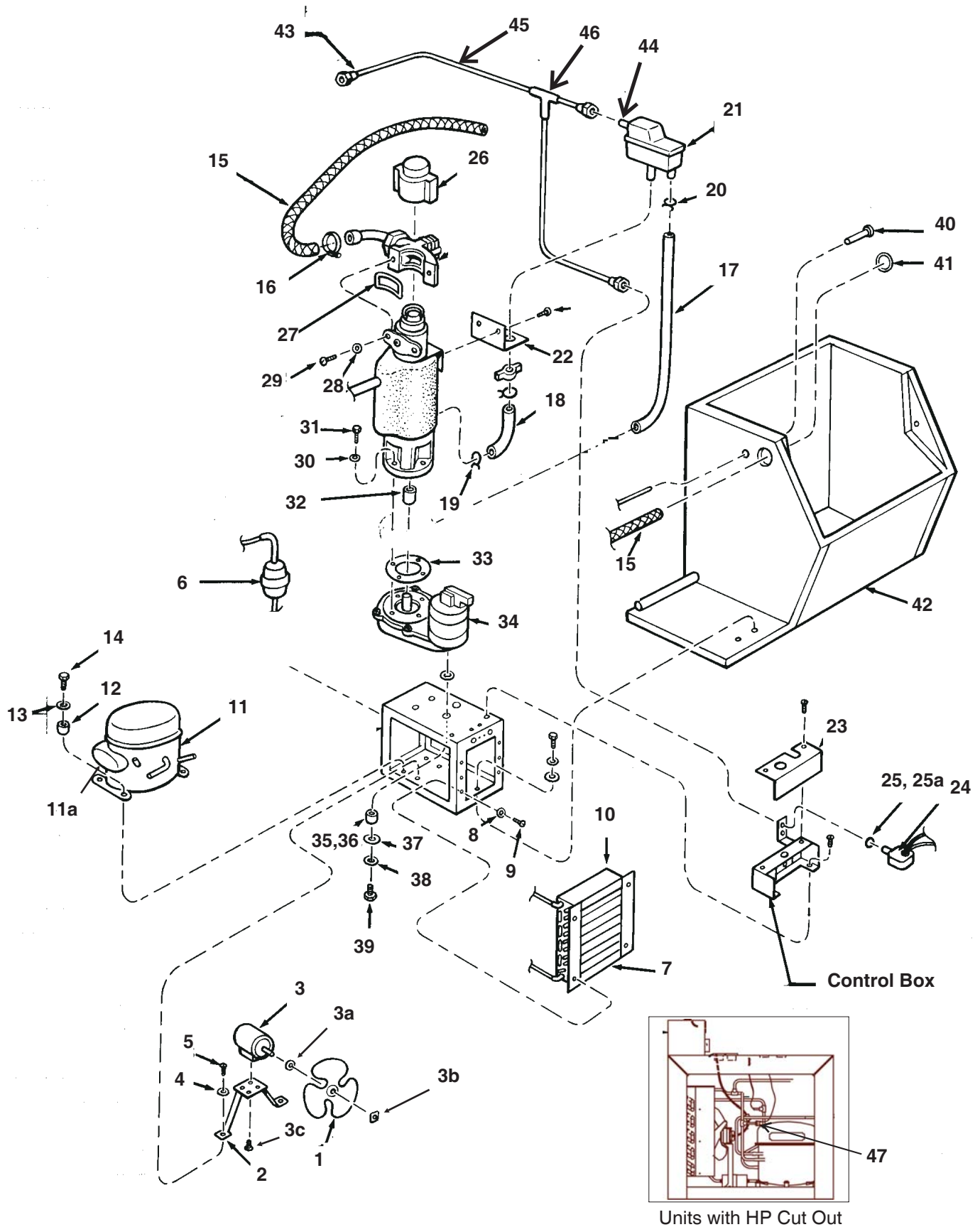

AFE325 Service Parts

Major Parts

Item Number	Part Number	Description	Item Number	Part Number	Description
1	18-3728-01	Fan blade	21	02-2217-01	Reservoir & float valve
2	A25548-015	Fan motor bracket		02-2217-02	Float valve only
3	18-8752-21	60 Hz fan motor	22	A28240-001	Reservoir bracket
	18-8752-26	50 Hz fan motor	23	A28214-001	Control box cover
3a	18-8752-10	Vibration pad	24	11-0296-00	Low water pressure switch
3b	18-8752-11	Fan blade nut	25	13-0617-26	O-Ring
3c	18-8752-12	Mounting screw	25a**	16-1046-01	Plastic water line fitting
4	03-1417-09	Lockwasher	26	13-0815-01	Evaporator cap
5	03-0571-00	Screw	27	13-0679-00	Spout gasket
6	02-3319-01	Drier	28	03-1417-07	Lockwasher
7	18-3727-01	Condenser	29	03-1544-05	Screw
8	03-1417-06	Lockwasher	30	03-1417-12	Lockwasher
9	03-1404-15	Screw	31	03-1420-04	Screw
10	A38486-001	Fan shroud	32	A29915-002	Splined coupling
11	18-8918-21	60 Hz compressor*	33	13-0628-00	Gasket
	18-8918-26	50 Hz compressor*	34	02-4399-21	60 Hz gearmotor
		A series (Tecumseh compressor) parts:		A36546-006	50 Hz gearmotor
	18-8746-29	60 Hz start capacitor	35	13-0639-00	Grommet
	18-8746-28	60 Hz start relay	36	A24925-001	Spacer
	18-8746-27	60 Hz overload	37	03-1408-02	Spacer washer
	18-8746-25	50 Hz start capacitor	38	03-1410-03	Lockwasher
	18-8746-24	50 Hz start relay	39	03-1405-45	Screw
	18-8746-23	50 Hz overload	40	13-0639-00	Grommet
		B series (Danfoss compressor) parts:	41	13-0806-01	Sealing pad
	18-1903-60	60 Hz relay w/overload	42	A34072-001	Cabinet & Bin (foamed) for painted
	18-1901-60	60 Hz start capacitor		A34072-002	Cabinet & Bin (foamed) for stainless steel
	18-1903-61	50 Hz relay w/overload			
	18-1901-61	50 Hz start capacitor			
12	18-4700-28	Grommet	43**	16-1081-01	90 degree plastic inlet fitting
	18-0108-41	Sleeve		16-0835-01	Brass adapter for above
13	03-1408-29	Washer	44**	16-0871-01	Brass insert
	03-1407-07	Washer	45**	13-0895-01	Poly tubing
14	03-1405-20	Screw	46**	16-1040-01	Plastic T
15	A28042-003	Ice tube	**Prior models used copper water inlet line.		
16	02-0179-02	Hose clamp	47	11-0501-04	High pressure cut out
17	13-0079-03	Reservoir overflow tube, order by the foot (3' req.)			
18	13-0674-09	Reservoir to evap tube, 2.5" req. order by the foot			
* Includes drier, starting components and tubing					
19	02-0694-00	Hose clamp, use w/item 18			
20	02-0534-01	Hose clamp, use w/item 17			

AFE325 Service Parts

Evaporator, Auger, Bearings & Water Seal

Item Number	Part Number	Description
1	A18430-002	Spout plate
2	03-1409-14	Washer
3	03-1506-01	Screw
4	A08162-000	Cap hook
5	03-1558-03	Retainer Ring
6	A07701-000	Cap
7	03-0758-00	Screw
8	A07699-000	Washer
9	A15508-020	Bearing & Retainer
9a	02-0695-20	Bearing
9b	13-0617-16	O-ring
10	13-0617-29	O-ring
11	A29478-020	Auger
12	02-1300-01	Water seal
13	02-0417-20	Bottom bearing
14	03-1505-00	Gasket
15	03-1410-04	Washer
16	03-1405-42	Cap screw
17	08-0595-01	Adapter
18	A29360-020	Evaporator
19	03-1405-38	Screw
20	02-4404-01	Threaded cap

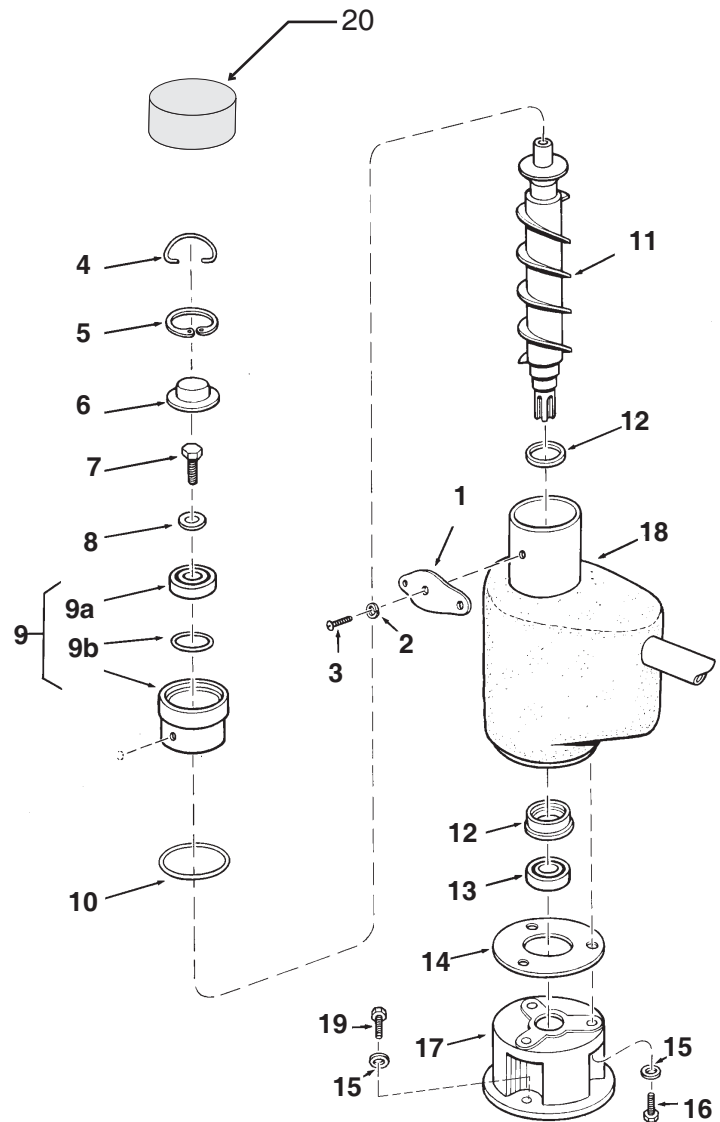

Note: Items 4 and 6 not used with threaded cap.

AFE325 Service Parts

Spout

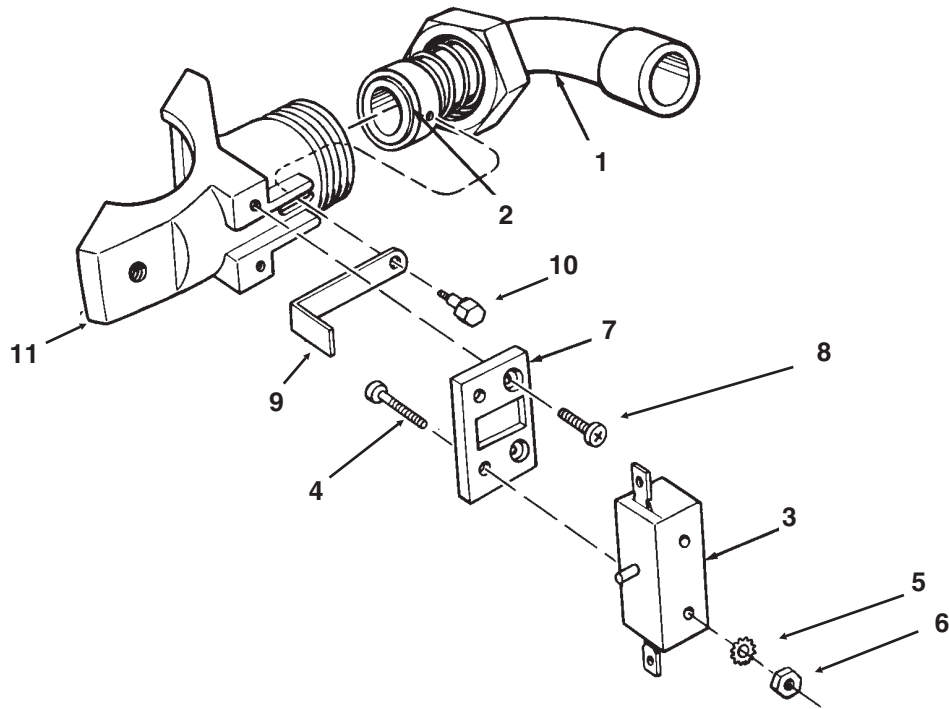

Item Number	Part Number	Description
1	A26542-001	Ice discharge tube (includes spring & collar)
2	13-0617-41	O - Ring
3	12-1664-00	Switch
4	03-1418-28	Screw
5	03-1417-01	Lockwasher
6	03-1406-01	Nut
7	02-2377-01	Thermal barrier
8	03-1418-01	Screw
9	A27511-001	Lever
10	A25305-001	Shoulder screw
11	A24934-001	Spout

AFE325 Service Parts

Gear Reducer and Motor

Item Number	Part Number	Description
1	A27494-001	Centrifugal switch kit
2	12-2059-01	Switch
3	A27494-001	Housing
4	03-1403-77	Screw
5	A30579-001	Shaft & actuator
6	03-1408-36	Washer
7	A38487-001	Motor housing
8	A28168-001	Cooling fan
9	no number	Part of item 10
10	A37707-021	60 Hz motor kit*
	A38501-001	50 Hz motor kit*
11	03-1408-08	Washer
12	02-1501-00	Bearing
13	02-3969-20	Grease seal (input)
14	02-1503-00	Grease seal (output)
15	see item 23	Gear case cover
16	03-1408-21	Washer**
17	03-1408-04	Washer**
18	02-2445-01	Output shaft**
19	03-1515-03	Retaining ring**
20	03-1602-01	Woodruff key**

Notes:

* Motor kit includes items 3, 7, 8, 9, 10, 11, 12

** Does not apply to 02-4399-21 or 02-4399-24.

02-4398-21 gear reducer kit includes items 13-30 and oil.

Correct oil charge is 5 oz.

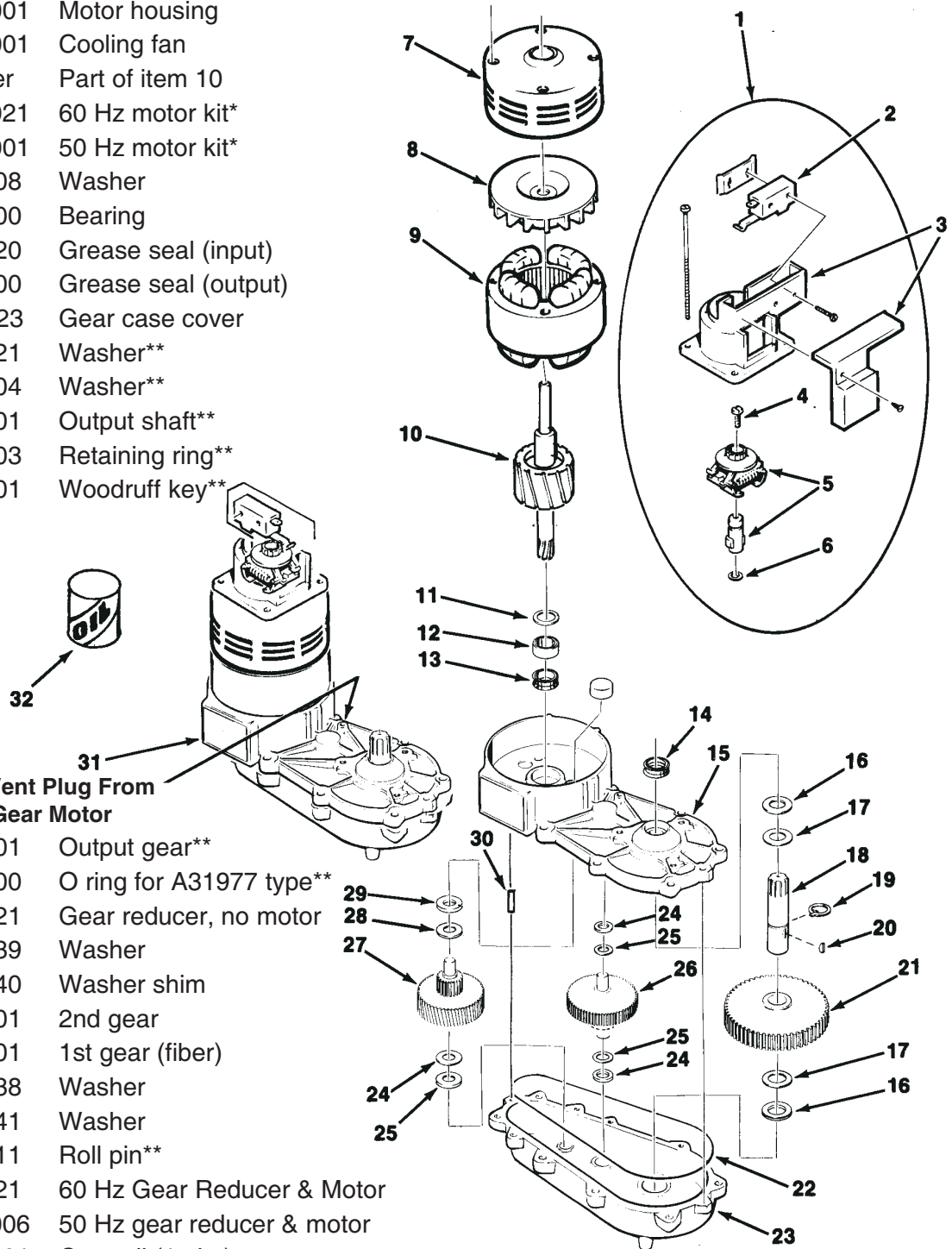

Remove Rubber Vent Plug From Replacement Gear Motor

21	02-2444-01	Output gear**
22	02-1505-00	O ring for A31977 type**
23	02-4398-21	Gear reducer, no motor
24	03-1408-39	Washer
25	03-1408-40	Washer shim
26	02-2439-01	2nd gear
27	02-2438-01	1st gear (fiber)
28	03-1408-38	Washer
29	03-1408-41	Washer
30	03-0774-11	Roll pin**
31	02-4399-21	60 Hz Gear Reducer & Motor
	A36549-006	50 Hz gear reducer & motor
32	A25835-001	Gear oil (1 pint)

AFE325 Service Parts

Control Box

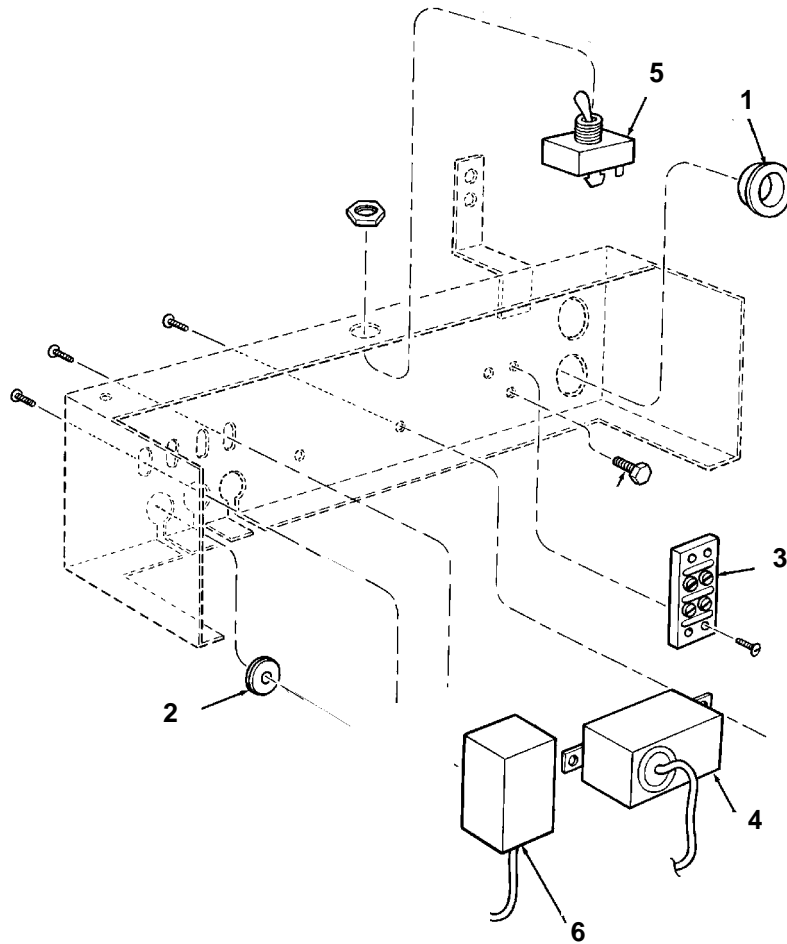

Item Number	Part Number	Description
1	12-1213-10	Snap bushing
2	13-0557-00	Grommet
3	12-0813-04	Terminal strip
4	11-0354-20	Bin thermostat
5	12-0426-01	Master switch
6	11-0402-21	Auger delay pressure control

AFE325 Service Parts

Wiring Diagram

A36156-001

THIS UNIT MUST BE GROUNDED
USE COPPER CONDUCTORS ONLY

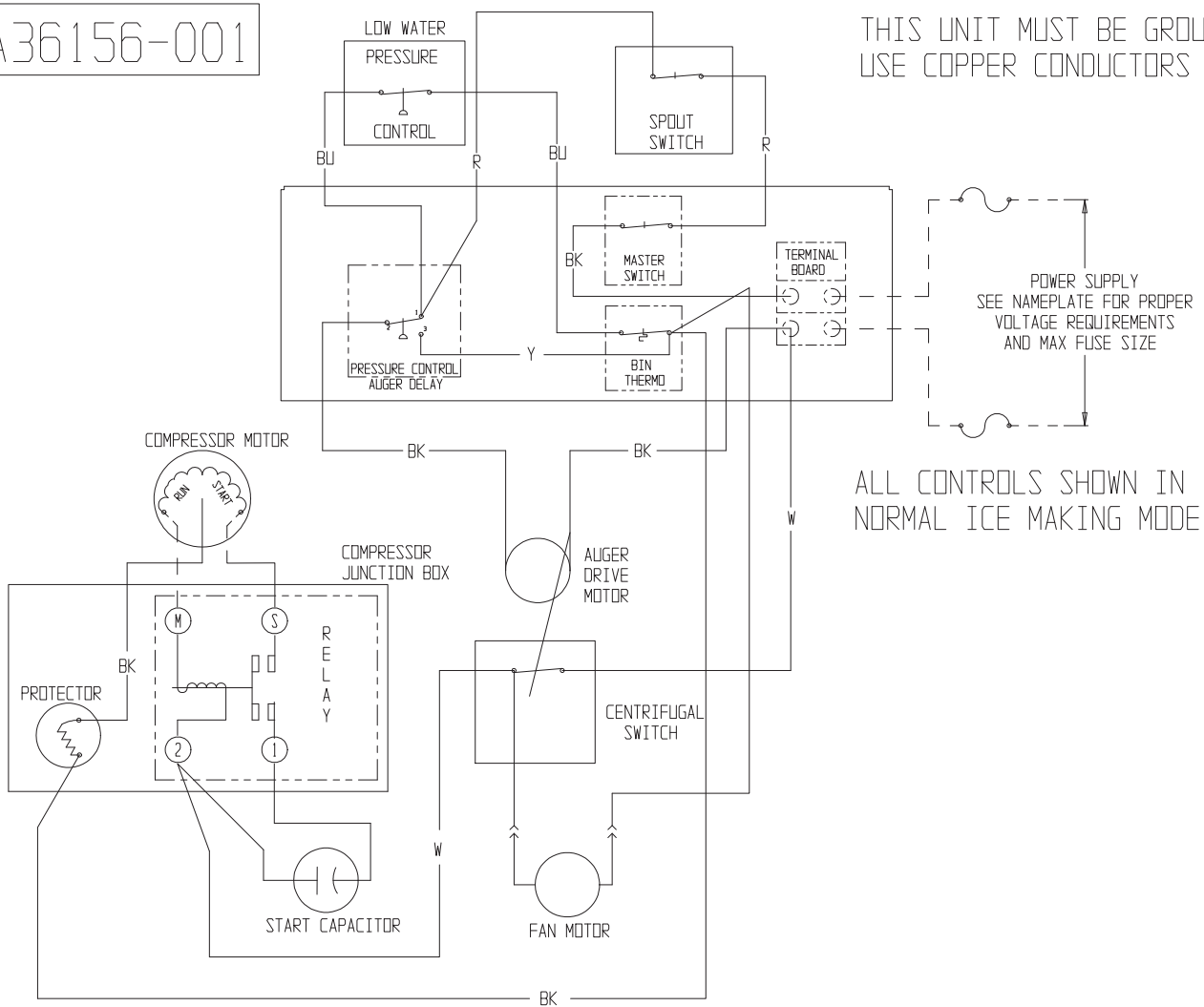

ALL CONTROLS SHOWN IN
NORMAL ICE MAKING MODE

AFE325 Service Parts

Schematic Diagram

ALL CONTROLS SHOWN IN
NORMAL ICE MAKING MODE

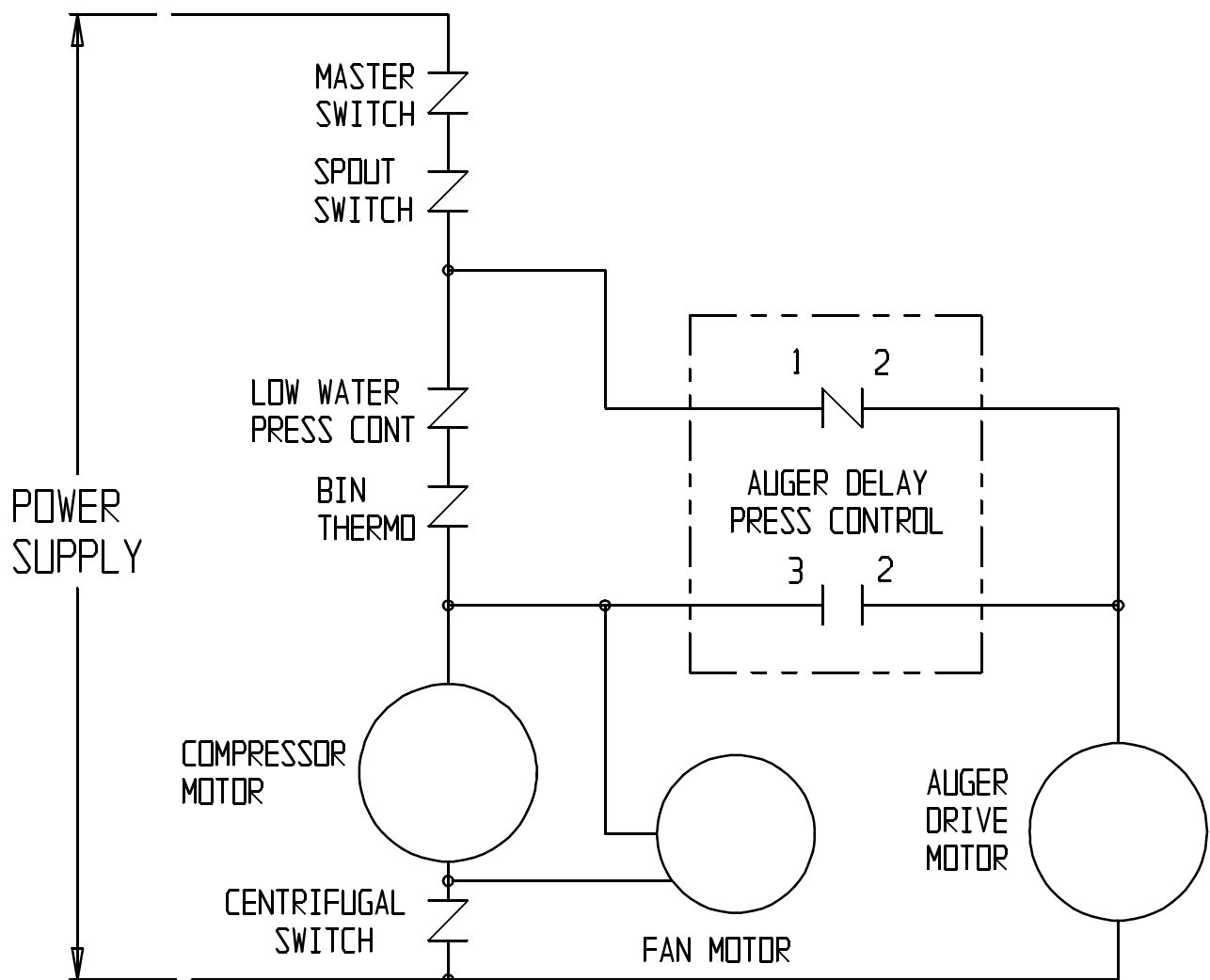

AFE325 Service Parts

Units with High Pressure Cut Out

17-3135-01

THIS UNIT MUST BE GROUNDED
USE COPPER CONDUCTORS ONLY

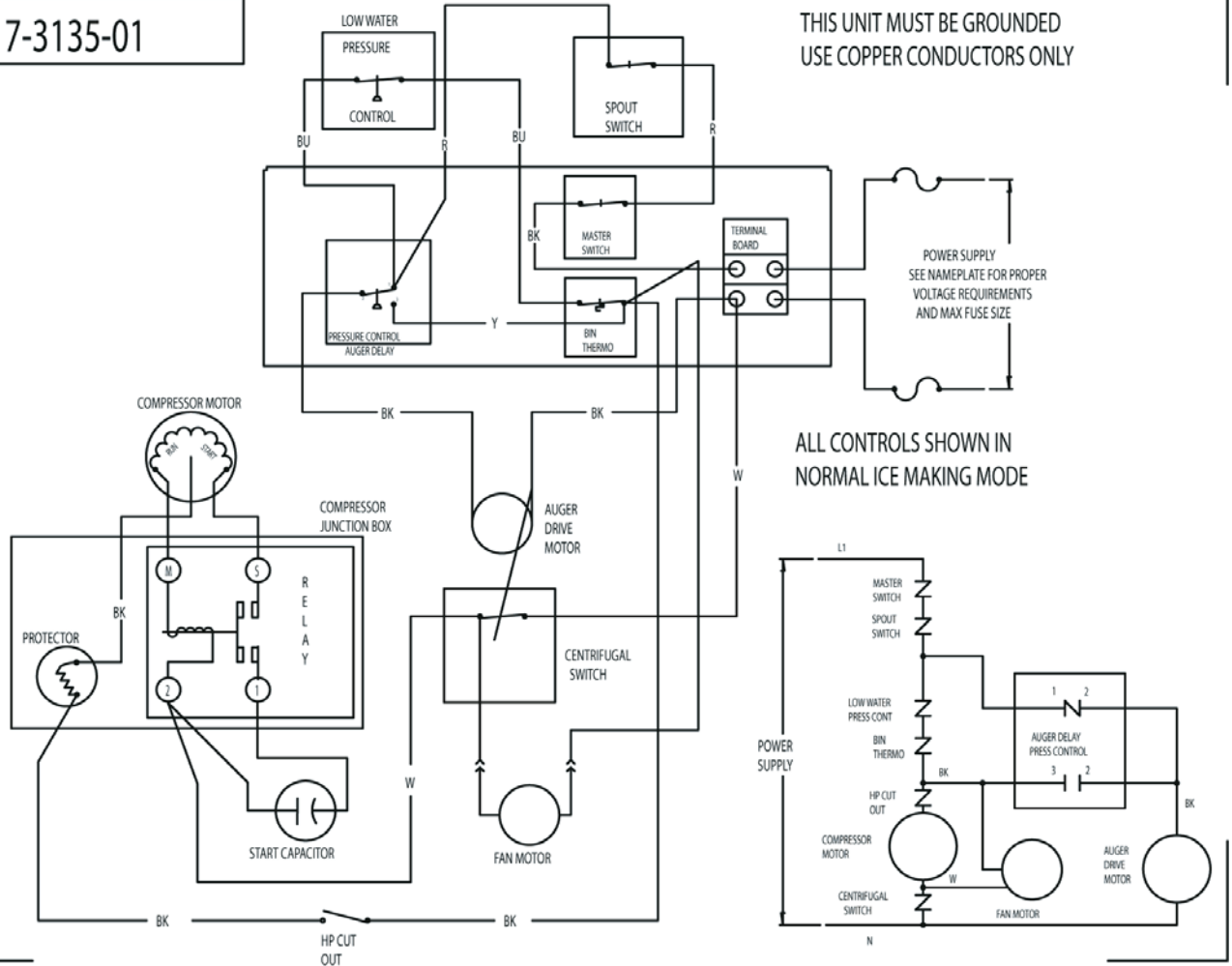

ALL CONTROLS SHOWN IN
NORMAL ICE MAKING MODE



Bulletin Number: PS - 5 - 2005

Bulletin Date: April 2005

SERVICE BULLETIN

Subject: AFE325 and AFE400 Model Number and Compressor Change

The model series number of these ice machines has been changed due to the introduction of a new compressor. The new model numbers are:

- AFE325AS-1B
- AFE325AS-6B
- AFE400A-1C
- AFE400W-1C
- AFE400A-6C
- AFE400W-6C

All the above use a Danfoss compressor. The new service compressor's part numbers are:

- 18-8918-21 for 60 Hz (-1)
- 18-8918-26 for 50 Hz (-6)

The above service compressors are kits that include the starting components and tubing to replace the prior Tecumseh (service compressors 18-8746-21 and 18-8746-26 will be discontinued).

Starting components for the new compressors:

- 60 Hz start relay w/overload: 18-1903-60
- 60 Hz start capacitor: 18-1901-60
- 50 Hz start relay w/overload: 18-1903-61
- 50 Hz start capacitor. 18-1901-61