

# E1848 DEEP FAT FRYER

# FRYER FITMENTS

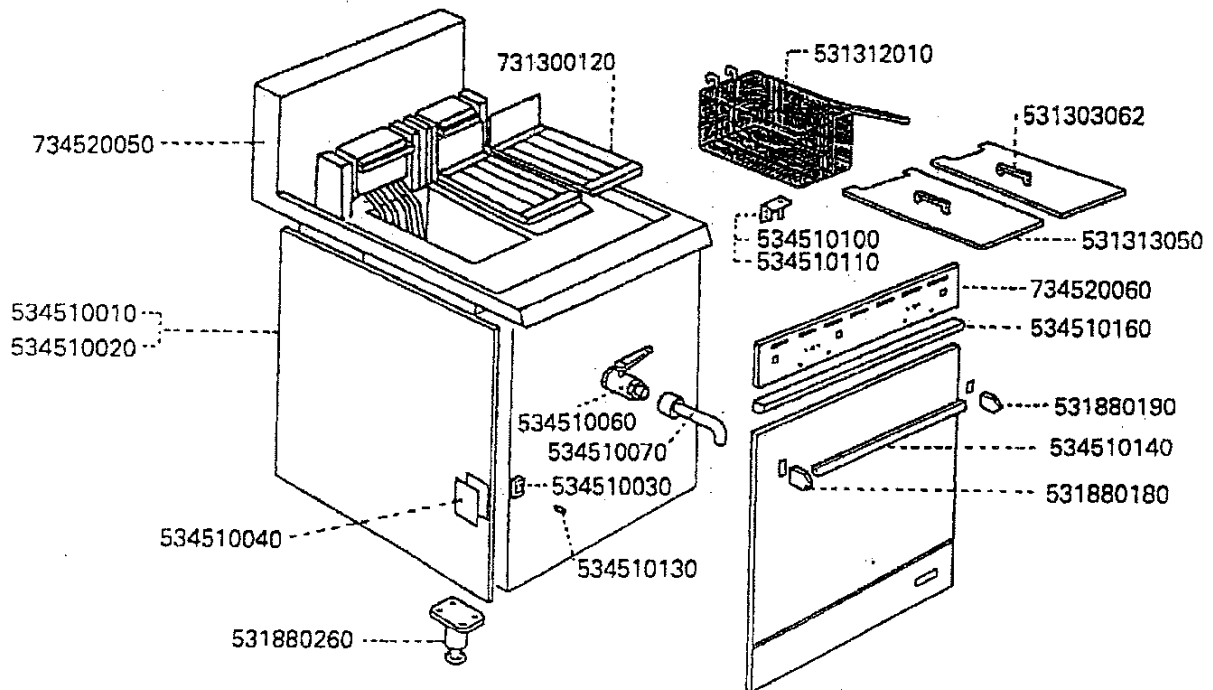

Code	No.	Description
E10	531312010	Chip Basket
B05	531313050	Dust Cover Handle
E12	531303062	Dust Cover c/w Handle
D12	731300120	Element Guard
B05	531880180	Door Handle Bracket and Gasket (L.H.)
B05	531880190	Door Handle Bracket and Gasket (R.H.)
C09	531880260	Foot Assembly
F08	534510010	Outer Side Panel (L.H.)
F09	534510020	Outer Side Panel (R.H.)
B07	534510030	Door Catch
C05	534510040	Blanking Plate
N08	734520050	Hob and Pan
E05	534510060	Drain Cock
C12	534510070	Drain Tube
C01	534510100	Door Top Hinge
C01	534510110	Door Bottom Hinge
J06	534510120	Complete Door (Not Illustrated)
B01	534510130	Door Keeper Stud
C10	534510140	Door Handle Bar
C12	734520060	Control Panel
D12	534510160	Trim

Sheet Reference Number

E1848/0192/001

**Falcon Catering  
Equipment**  
Commercial and institutional  
catering equipment



Falcon Catering Equipment is a  
business name of  
Glynwed Consumer & Building Products Ltd  
a member of the  
Glynwed International plc  
group of companies

1 2 3 4 5 6 7 8

IF IN DOUBT ASK

DO NOT SCALE  
First Angle Projection

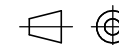

Item	Description	E1808 Falcon Part No.	E1838 Falcon Part No.	E1848 Falcon Part No.
1	Element 5kW	731300000	-----	731300000
2	Element 4kW	-----	731310000	-----
3	Contacteur Operating	734510200	734510200	734510200
4	Contacteur Safety	734510100	734510100	734510100
5	Fuse 2A Anti Surge	734510280	734510280	734510280
6	Indicator Amber	731310070	731310070	731310070
7	Indicator Red	731310060	731310060	731310060
8	Thermostat Knob	734510240	734510240	734510240
9	Switch On/Off	734510150	734510150	734510150
10	Thermostat PCB	734510160	734510160	734510160
11	Potentiometer	734510120	734510120	734510120
12	Safety Limit Device	734510170	734510170	734510170
13	Thermocouple	734510020	734510020	734510020

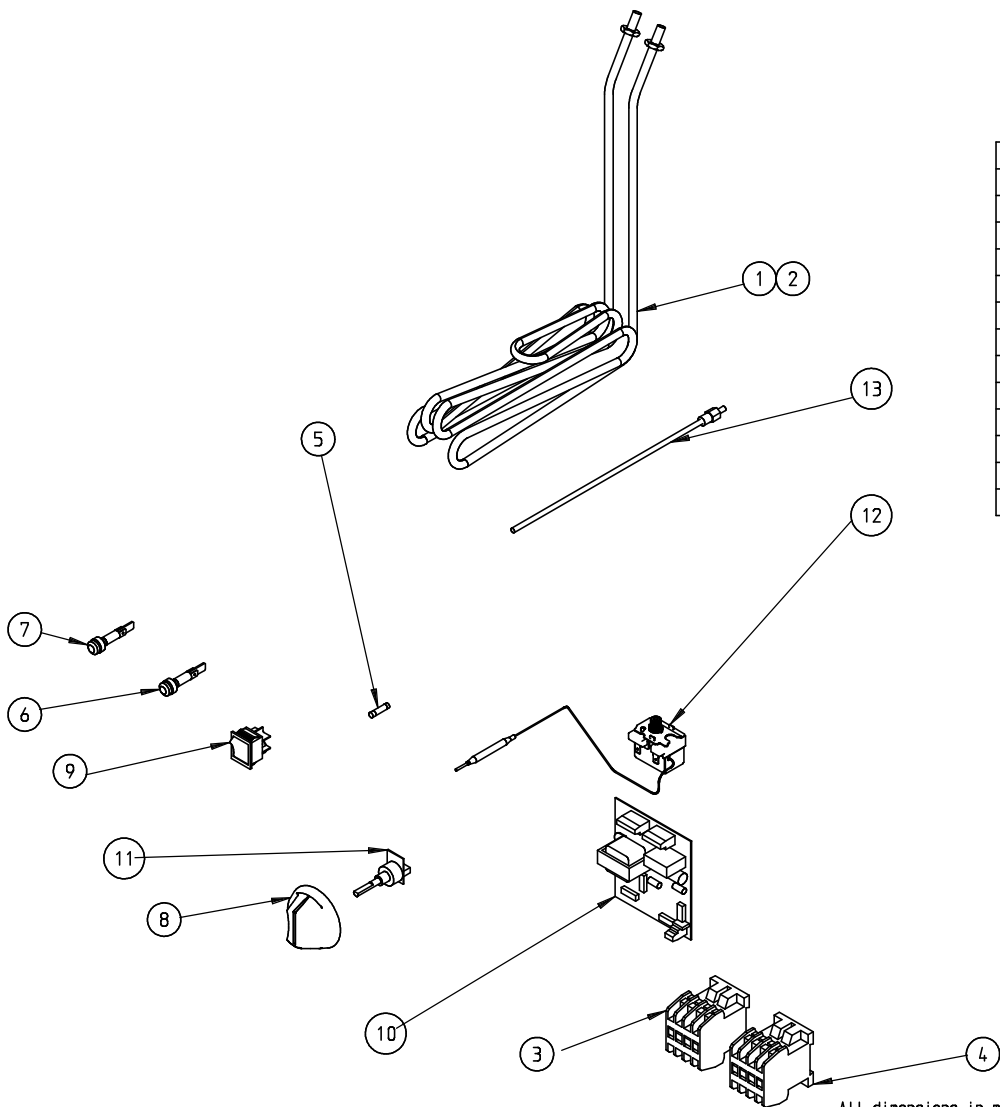

All dimensions in millimetres. Tolerance- Linear  $\pm 0.5\text{mm}$  Angular  $\pm 0.5^\circ$  (or as stated). All sharp edges to be removed from sheet metal parts.

Issue	Mod No.	Alteration	Zone	Drawn by	Date



This part is common to the following units

No reproduction or publication of this drawing may be made and no article may be manufactured or assembled in accordance with this drawing without prior written consent. This prohibition is a term of any contract relating to this drawing. Rights reserved under the Copyright Act 1956 as amended by the Design Copyright Act 1968.

Drawn	I. HAMILTON	Product	E1808/38/48 FRYERS	
Date	28-04-06	Title	SPARES DIAGRAM	
Scale		Drawing Number	AD44788	
Matt.		Issue		
No. off		Finish		
Bin No.		Kraus No.		