

# DISHWASHER

ELECTROMECHANICAL SWITCHES  
LOWER AND UPPER WASHING

TYPE: 38R

Accessories

BOOSTER PUMP

DVGW

WATER SOFTNER

DETERGENT DISPENSER

DRAIN PUMP

---

## Spare Parts Manual

---

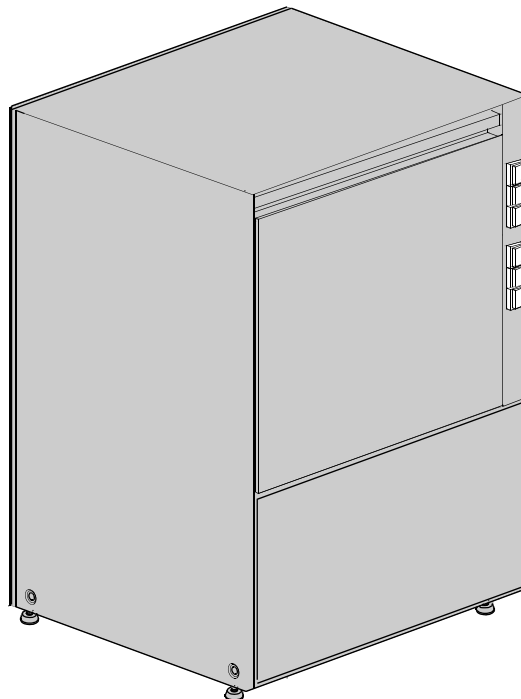

## INFORMAZIONI GENERALI

Questo catalogo serve per richiedere con esattezza le parti di ricambio

Nelle ordinazioni indicare:

1) il numero dei codici dei particolari seguito dalla descrizione e la quantità desiderata;

2) Il codice alfa-numerico presente nella seconda colonna della tabella ;

**I disegni delle parti di ricambio sono solo indicativi e non rappresentano il pezzo in oggetto.**

**I dati contenuti in questo catalogo sono indicativi e possono essere soggetti a modifiche senza impegno di preavviso.**

## ALLGEMEINE INFORMATIONEN

Dieser Ersatzteilkatalog dient zur genauen Angabe der Teile bei Ersatzteilbestellungen.

Bei Ersatzbestellung ist folgendes anzugeben:

1) Die Bestellnummer der Ersatzteile mit der entsprechenden Beschreibung genaue Menge;

2) Der alpha-numerischer Code auf der zweiten Reihe in dein Spcluld;

**Die Zeichnungen der Ersatzteile sind nur als Hinweise gedacht und stellen nicht das betroffene Teil dar.**

**Bei den im Katalog angeführten Daten handelt es sich um Anhaltsdaten, die jederzeit, ohne Vorankündigung, geändert werden können.**

## GENERAL INFORMATION

The present spare parts order exactly the right spare parts

When ordering specify:

1) the part's code number followed by its description and quantity needed;

2) The alpha-numeric code is in the second column in the chart;

**Spare parts drawings are general and do not represent the part.**

**The contents of this catalogue are general and can undergo changes without prior notice.**

## INFORMACIONES GENERALES

El presente catálogo sirve para pedir con exactitud las partes de repuesto

En los pedidos se debe indicar:

1) el número de código de la parte y a continuación la descripción cantidad deseada;

2) El código alfanumerico presente en la segnada columna de la tabla;

**Los diseños de las partes de recambio son solo indicativos y no representan la pieza en cuestión.**

**Los datos contenidos en el presente catálogo son indicativos y pueden modificarse sin aviso previo.**

## INFORMATIONS GENERALES

Ce catalogue permet de commander correctement les pièces détachées

Les commandes doivent être passées en indiquant:

1) le numero de code des pièces détachées suivi de leur description quantité désirée;

2) le code alphanumérique dans la deuxième colonne du tableau;

**Les plans des pièces détachées sont fournis seulement à titre indicatif et ne représentent pas la pièce concernée.**

**Les données de ce catalogue sont citées seulement à titre indicatif et peuvent être l'objet de modifications sans avis préalable.**

ESEMPIO  
EXAMPLE  
EXEMPLE  
BEISPIEL

Rif.	Codici
MODULE:Particolari	
10505	540903
10510	540908
10515	15065/A
10520	540086
10525	540028

**Note**

Tutte le informazioni riportate si intendono aggiornate alla data di stampa. Il Produttore si riserva il diritto di apportare qualsiasi modifica richiesta dallo sviluppo evolutivo dei suddetti prodotti.

Per la sicurezza, la garanzia, l'affidabilità ed il valore della lavastoviglie usa solo ricambi originali. **Per alcuni codici, sono richieste quantità minime d'ordine.**

**Attenzione**

Questo libretto è parte integrante della lavastoviglie e, in caso di passaggio di proprietà, deve essere consegnato al nuovo acquirente.

**Remarque**

Toutes les informations contenues dans ce manuel s'entendent mises à jour à la date d'impression. En raison du développement constant de ses produits, usine se réserve le droit d'apporter à tout instant les modifications qu'elle jugera utiles.

Pour la sécurité, la garantie, la fiabilité et la valeur de votre lavevaisselles n'utilisez que des pièces de rechange d'origine. **Pour quelque référence on demande un minimum de pièces par commande**

**Attention**

Ce manuel doit être considéré comme partie intégrante de la la lavevaisselles, en cas de transfert de propriété, doit toujours être remis au nouveau propriétaire.

**Note**

The information contained herein is valid at the time of going to print. The Company reserves the right to make any changes required by the future development of the above-mentioned products.

For your safety, as well as to preserve the warranty reliability and worth of your dishwashers, use original spare parts only. **For some codes a minimum quantity for order is required.**

**Warning**

This manual forms an integral part of the dishwashers and - if a transfer of title occurs - must always be handed over to the new owner.

**Hinweis**

Die Der Hersteller behält sich das Recht vor, jegliche, durch eine Weiterentwicklung der genannten Produkte bedingte Änderungen vornehmen zu können.

Verwenden Sie für Ihre Sicherheit, die Garantie, die Zuverlässigkeit und den Wert Ihrer machine originale Ersatzteile. **Für bestimmte Code nummer werden mindesten bestellungen verlangt.**

**Achtung**

Diese Betriebsanleitung ist Bestandteile des machine und muss bei seinem Weiterverkauf dem neuen Besitzer ausgehändigt werden.



---

**Code** 999XYYYY **CL/Part**

**Model DESCRIPTION** 

**S/N** 04012345 **Type** .....

400VAC3N 50HZ 8A  
3500W 500W

 16A

**IPX3**

Pressione Dinamica alimentazione idrica **200-500**  
 Pression dynamique arrivee d'eau  
 Dynamic pressure water supply  
 Dymanischer Druck assereinlauf

Pressione dinamica vapore saturo  
 Pression dynamique vapeur satuee  
 Dymanischer Druck gesattigter Dampf  
 Pression Dinamica Vapor Saturado

**TECHICAL SPECIFICATION**

**MADE IN ITALY**

Temperatura massima acqua in ingresso **60°C**  
 Temperature max eau a l'entre  
 Maximale Temperatur Wasseranschlu  
 Maximum Water temperature in-feeding

---

Model 

S/N 

**CODE 999 XX YYYY**

FAMIGLIA PRODOTTO  
 FAMILY PRODUCT  
 FAMILLE DU PRODUIT  
 FAMILIA PRODUCTO  
 FAMILIE DES PRODUKTES

CODICE MODELLO  
 CODE MODEL  
 CODE ARTICLE  
 CODIGO MODELO  
 KODE VON MODELL

**S/N 04 012345**

ANNO  
 YEAR  
 ANNÉE  
 AN<sup>o</sup>  
 JAHR

NUMERO DI SERIE  
 SERIAL NUMBER  
 NUMÉRO DI SÉRIE  
 NUMERO DI SERIE  
 SERIENNUMMER



## 1. Spare parts

General body parts.....	7
Lockup system .....	11
Control panel and switches.....	13
Electric control components.....	17
Solenoid valve group .....	19
Solenoid valve group .....	21
Booster pump.....	23
DVGW .....	25
Water softner group.....	27
Rinse aid dispenser group.....	29
Boiler group .....	31
Connection group .....	33
Wash pump .....	35
Dosing detergent group.....	37
Dosing detergent group.....	39
Drain pump group.....	41

**Pressure switch group with air trap ...43**

**Turret group with rotating arms .....45**

## 1.1 Voltage codes

Volt	Voltage code
A	3/N/PE~380-400V 50-60Hz
D	3/PE~200-210V 50-60Hz
F	2/PE~220-240V 50-60Hz
G	3/N/PE~415V 50-60Hz
H	3/PE~220-230V 50-60Hz
K	3/PE~380-400V 50-60Hz
L	3/PE~415V 50-60Hz
M	3/PE~440V 60Hz
P	1/N/PE~220-230V 50-60Hz
R	2/PE~220-240V 50-60Hz
U	1/N/PE~240V 50-60Hz
V	3/PE~240V 50-60Hz
W	1/N/PE~100-110V 50-60Hz

## 1.2 Product codes

Product code	Full name
Model codes	
em	ELECTROMECHANICAL SWITCHES
uw	LOWER AND UPPER WASHING
Type codes	
38R	38R
Accessory codes	
bp	BOOSTER PUMP
dvgw	DVGW
ws	WATER SOFTNER
dd	DETERGENT DISPENSER
dp	DRAIN PUMP

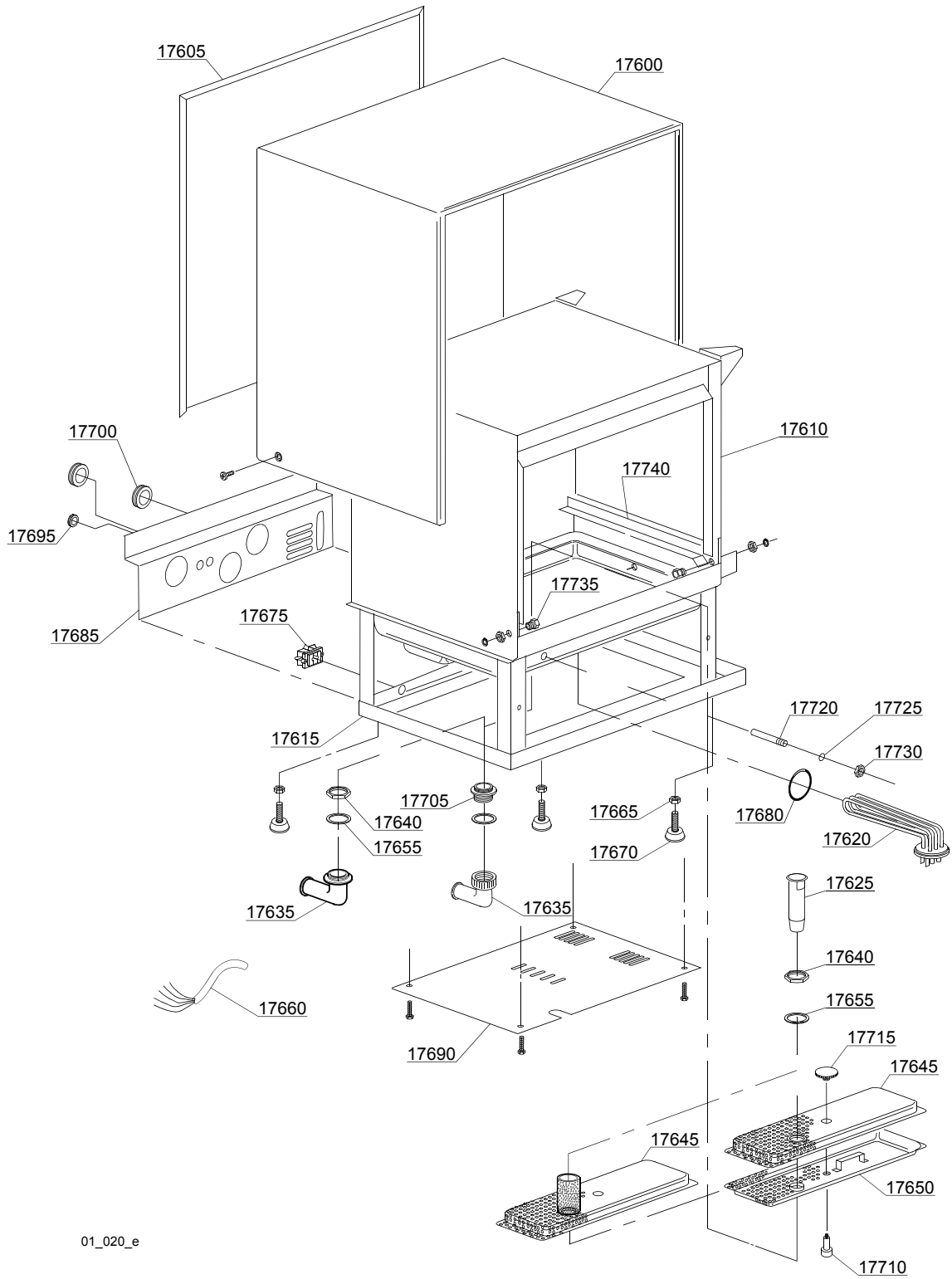

01\_020\_e

## Spare parts

ID	P-code	SN from	SN to	Mod.	Acces.	Volt	Description
<b>Module:General body parts</b>							
17600	575909		-				Cover
17605	575908		-				Back panel
17610	575901		-				Body
17610	575917		-		ws		Body
17615	575900		-				Base
17620	15047/E		-				2,5/2,72KW 230/240V heating element
17620	15047/A		-				2,7/2,94KW 230/240V 3 heating element
17625	15126		-				Overflow pipe
17625	150320		-		dp		Overflow pipe
17635	15613		-				Drain elbow
17635	10701		-		dp		Drain elbow
17640	11701/A		-				Stainless steel nut
17645	15932		-				Top filter assembly
17645	15970		-		dp		Top filter assembly
17650	15933		-				Rectangular steel filter
17655	13305		-				44x32x3 O-ring (minimum 5 pieces)
17660	15118		-				5x2,5x2500 cable
17660	15104/B		-				3x4x2500 cable
17665	11711		-				M10 zinc plated nut (minimum 20 pieces)
17670	10786		-				M10x25 Ø40 black foot (minimum 4 pieces)
17675	15065/A		-				Cable-fastener with screw
17680	13005		-				OR 151 NBR O-ring (minimum 5 pieces)
17685	575907		-				End piece protection
17690	15133		-				End piece protection
17695	13323		-				Ø13mm lead through rubber (minimum 2 pieces)
17700	13317		-				Ø40mm lead through rubber (minimum 2 pieces)
17705	15063		-				Steel floor drain
17710	15105		-				Complet steel lock-filter

em=ELECTROMECHANICAL SWITCHES, uw=LOWER AND UPPER WASHING, i=INSULATED MODEL  
38R=38R

bp=BOOSTER PUMP, dvgw=DVGW, ws=WATER SOFTNER, dd=DETERGENT DISPENSER, dp=DRAIN PUMP  
A=3/N/PE~380-400V 50-60Hz, D=3/PE~200-210V 50-60Hz, F=2/PE~220-240V 50-60Hz, G=3/N/PE~415V 50-60Hz,  
H=3/PE~220-230V 50-60Hz, K=3/PE~380-400V 50-60Hz, L=3/PE~415V 50-60Hz, M=3/PE~440V 60Hz, P=1/N/PE~220-  
230V 50-60Hz, R=2/PE~220-240V 50-60Hz,

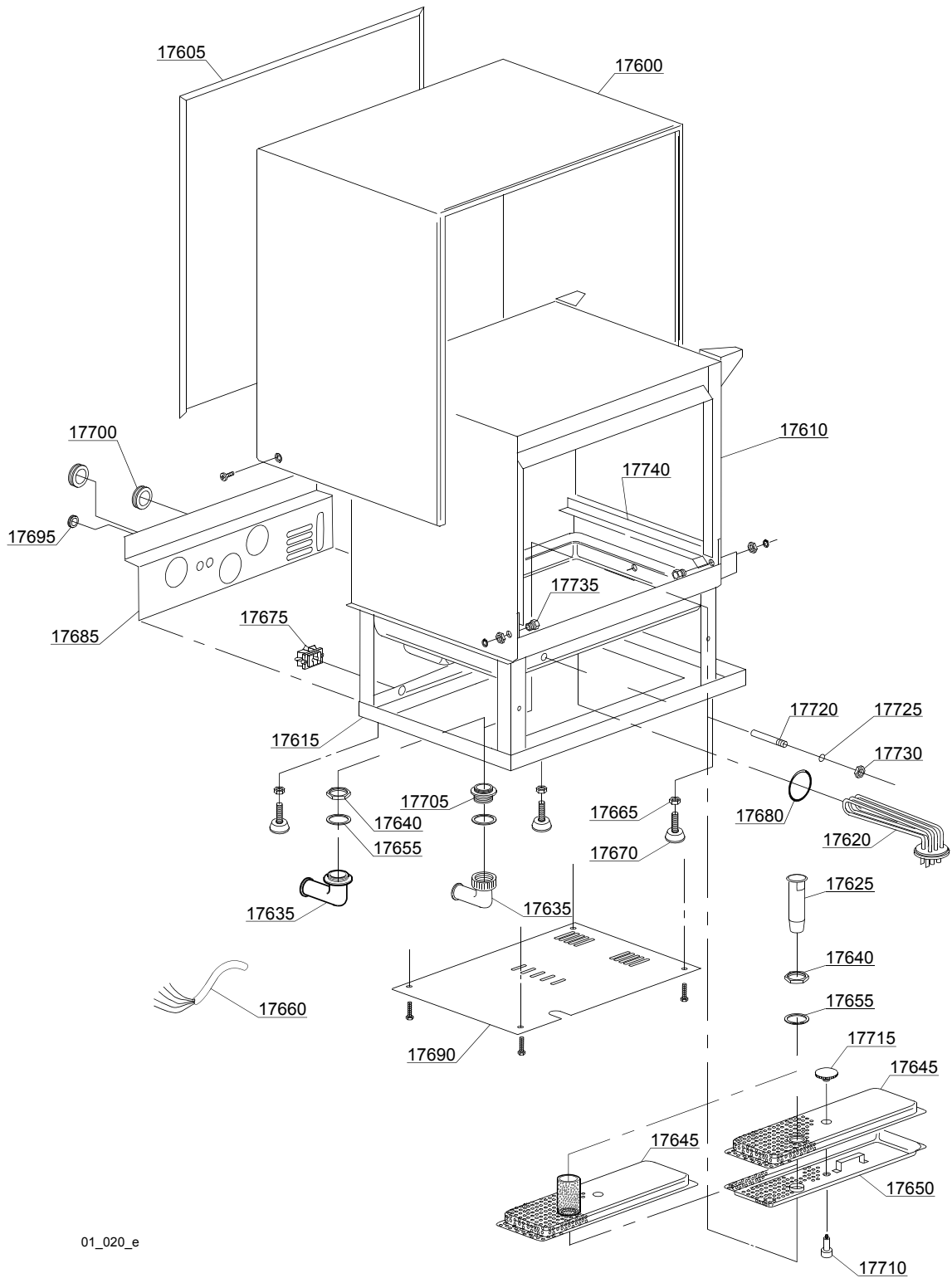

01\_020\_e

## Spare parts

ID	P-code	SN from	SN to	Mod.	Acces.	Volt	Description
<b>Module:General body parts</b>							
17715	15209		-				Pin for filter fixing
17720	12510		-				Thermostat feeler-holder
17725	13309		-				10x14x1,5 O-ring (minimum 20 pieces)
17730	11714		-				M10x1 stainless steel nut for thermostat feeler-holder
17735	11835		-				Brass bush with nut
17740	575904		-				Right internal slide
17740	575905		-				Left internal slide

em=ELECTROMECHANICAL SWITCHES, uw=LOWER AND UPPER WASHING, i=INSULATED MODEL  
38R=38R

bp=BOOSTER PUMP, dvgw=DVGW, ws=WATER SOFTNER, dd=DETERGENT DISPENSER, dp=DRAIN PUMP

A=3/N/PE~380-400V 50-60Hz, D=3/PE~200-210V 50-60Hz, F=2/PE~220-240V 50-60Hz, G=3/N/PE~415V 50-60Hz,  
H=3/PE~220-230V 50-60Hz, K=3/PE~380-400V 50-60Hz, L=3/PE~415V 50-60Hz, M=3/PE~440V 60Hz, P=1/N/PE~220-  
230V 50-60Hz, R=2/PE~220-240V 50-60Hz,

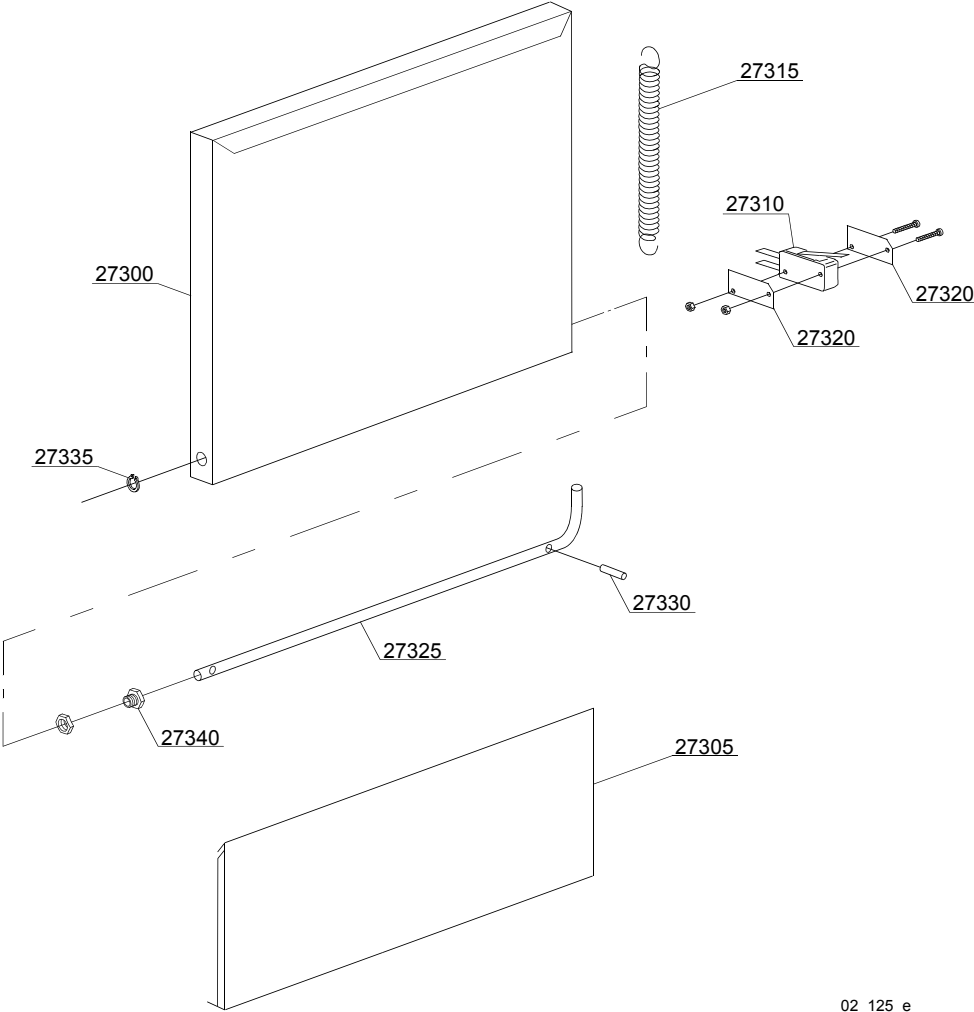

02\_125\_e

## Spare parts

ID	P-code	SN from	SN to	Mod.	Acces.	Volt	Description
<b>Module: Lockup system</b>							
27300	575936		-				Door with stainless steel handle
27305	575910		-				Lower door
27310	10704		-				Door microswitch
27315	10700/A		-				Spring
27320	10770		-				Insulation for door microswitch (minimum 3 pieces)
27325	15009		-				Rod door
27330	11501		-				M5x20 grub-screw (minimum 2 pieces)
27335	11815		-				Ø8 stainless steel snap ring (minimum 5 pieces)
27340	11835		-				Brass bush with nut

em=ELECTROMECHANICAL SWITCHES, uw=LOWER AND UPPER WASHING, i=INSULATED MODEL

38R=38R

bp=BOOSTER PUMP, dvgw=DVGW, ws=WATER SOFTNER, dd=DETERGENT DISPENSER, dp=DRAIN PUMP

A=3/N/PE~380-400V 50-60Hz, D=3/PE~200-210V 50-60Hz, F=2/PE~220-240V 50-60Hz, G=3/N/PE~415V 50-60Hz, H=3/PE~220-230V 50-60Hz, K=3/PE~380-400V 50-60Hz, L=3/PE~415V 50-60Hz, M=3/PE~440V 60Hz, P=1/N/PE~220-230V 50-60Hz, R=2/PE~220-240V 50-60Hz,

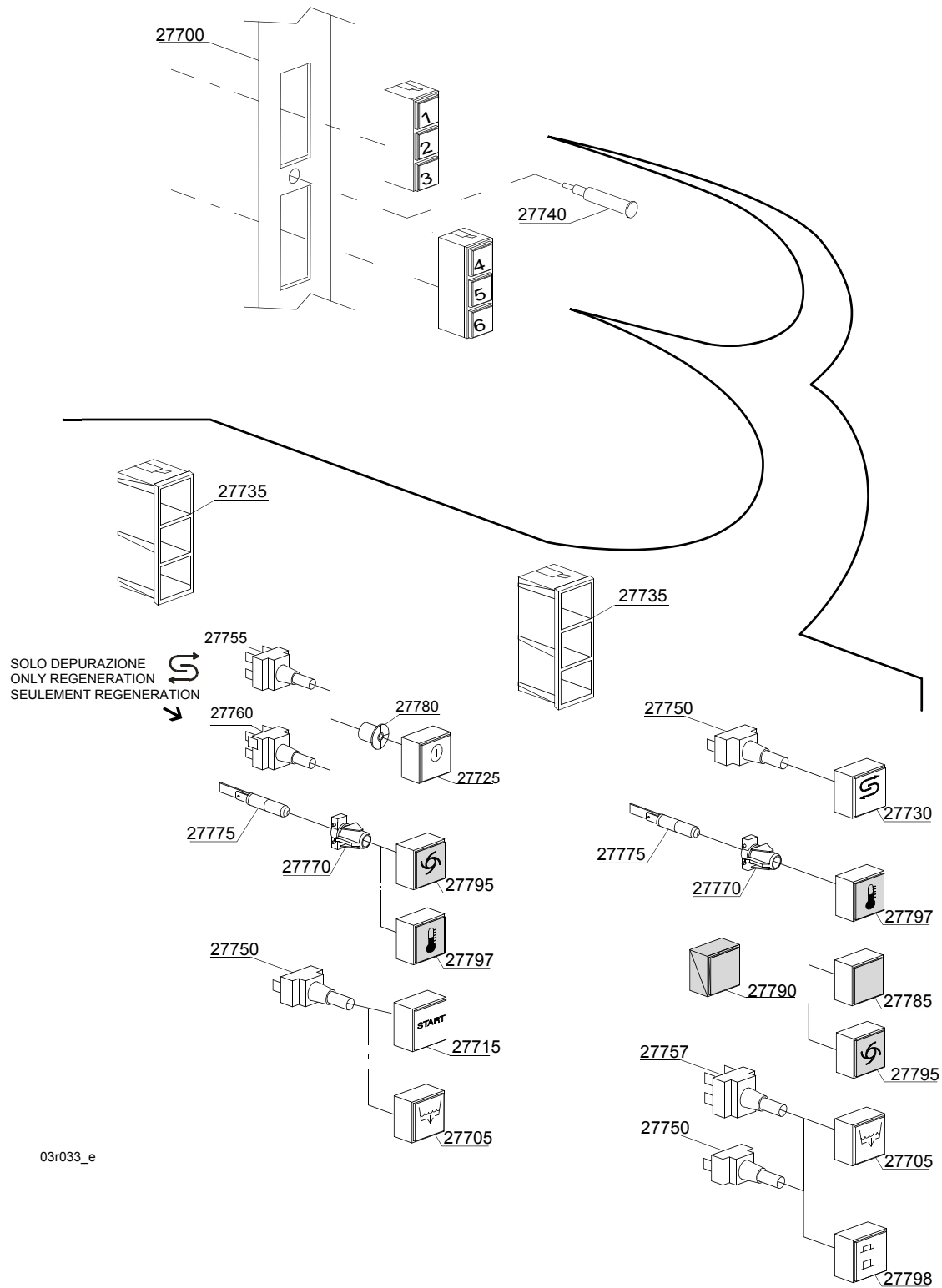

## Spare parts

ID	P-code	SN from	SN to	Mod.	Acces.	Volt	Description
<b>Module:Control panel and switches</b>							
27700	575918		-	em			Control panel
27705	15854		-	i,em	dp		Green drain pump push button
27705	15990		-	em	dp		Blu drain pump push button
27705	15991		-	em	dp		Yellow drain pump push button
27715	15873		-	i,em			Green start push button
27715	15986		-	em			Blu start push button
27715	15987		-	em			Yellow start push button
27720	15847		-	i,em			Green push button
27720	15817		-	em			Blu push button
27720	15819		-	em			Yellow push button
27725	15874		-	i,em			Green ON-OFF push button
27725	15988		-	em			Blu ON-OFF push button
27725	15989		-	em			Yellow ON-OFF push button
27730	15871		-	em	ws		Green regeneration push button
27730	15993		-	em	ws		Blu regeneration push button
27730	15858		-	em	ws		Yellow regeneration push button
27735	15843		-	em			Square black triple support
27735	15836		-	i,em			Square grey triple support
27740	10711/B		-	i,em			Pilot light
27745	15844		-	i,em			Push button support
27750	15813		-	i,em			16A unipolar switch
27755	15812		-	i,em			16A switch
27757	15800		-	i,em			16A bipolar switch
27760	15811		-	i,em			16A bipolar switch
27762	15811/A		-	i,em			16A bipolar switch
27770	15827		-	i,em			Pilot light support
27775	15826		-	i,em			Pilot light
27780	15824		-	i,em			Green-orange cam roll

em=ELECTROMECHANICAL SWITCHES, uw=LOWER AND UPPER WASHING, i=INSULATED MODEL  
38R=38R

bp=BOOSTER PUMP, dvgw=DVGW, ws=WATER SOFTNER, dd=DETERGENT DISPENSER, dp=DRAIN PUMP  
A=3/N/PE~380-400V 50-60Hz, D=3/PE~200-210V 50-60Hz, F=2/PE~220-240V 50-60Hz, G=3/N/PE~415V 50-60Hz,  
H=3/PE~220-230V 50-60Hz, K=3/PE~380-400V 50-60Hz, L=3/PE~415V 50-60Hz, M=3/PE~440V 60Hz, P=1/N/PE~220-  
230V 50-60Hz, R=2/PE~220-240V 50-60Hz,

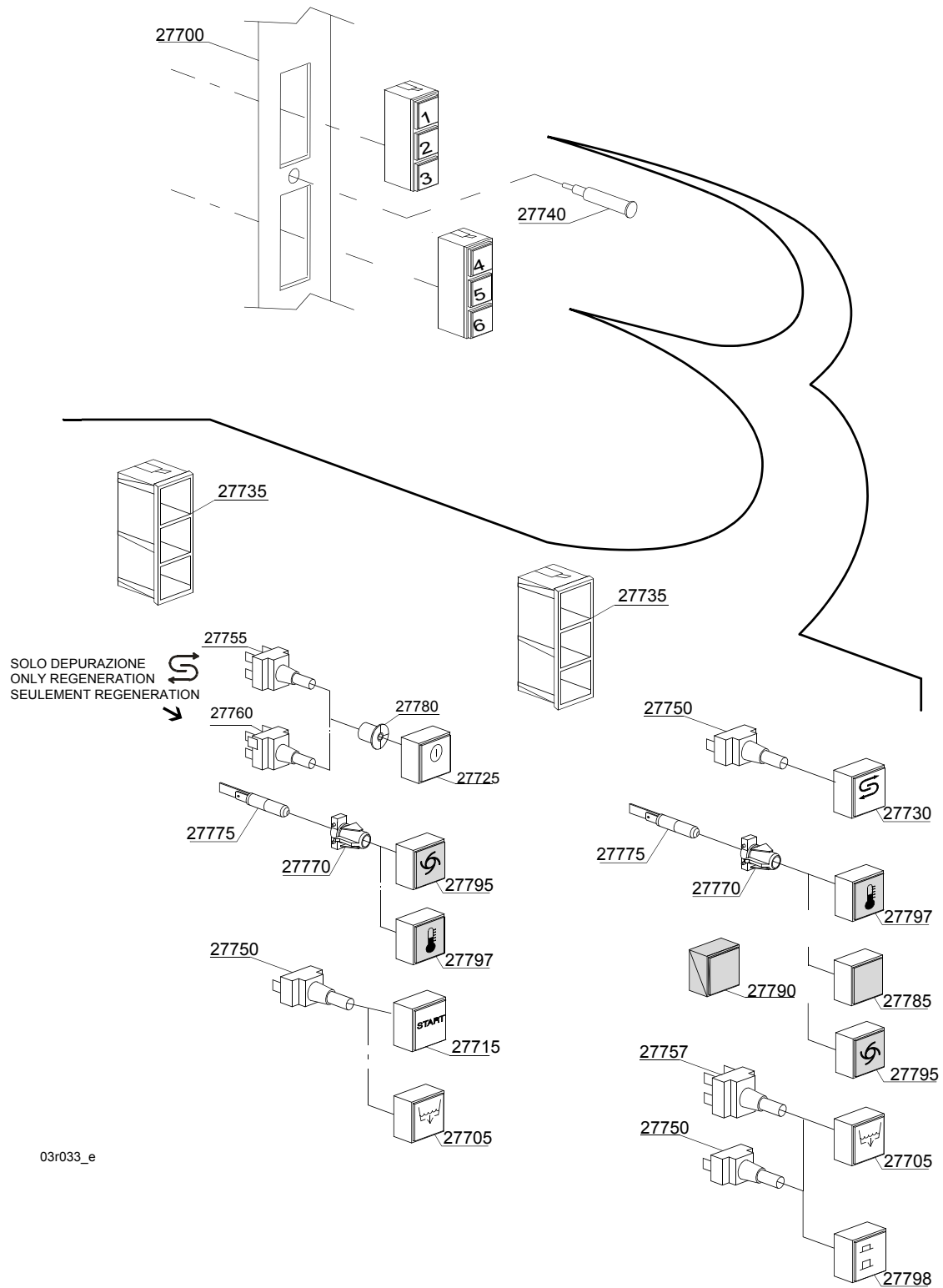

03r033\_e

## Spare parts

ID	P-code	SN from	SN to	Mod.	Acces.	Volt	Description
<b>Module:Control panel and switches</b>							
27785	15825		-	i,em			Green cover
27790	15880		-	i,em			Grey plug
27790	15845		-	em			Black plug
27795	15875		-	i,em			Green square cycle cover
27797	15876		-	i,em			Green square temperature cover
27798	15996		-	i,em			Green time selector switch
27798	15877		-	i,em			Blu time selector switch push button
27798	15839		-	i,em			Yellow push time selector switch push button

em=ELECTROMECHANICAL SWITCHES, uw=LOWER AND UPPER WASHING, i=INSULATED MODEL  
38R=38R

bp=BOOSTER PUMP, dvgw=DVGW, ws=WATER SOFTNER, dd=DETERGENT DISPENSER, dp=DRAIN PUMP  
A=3/N/PE~380-400V 50-60Hz, D=3/PE~200-210V 50-60Hz, F=2/PE~220-240V 50-60Hz, G=3/N/PE~415V 50-60Hz,  
H=3/PE~220-230V 50-60Hz, K=3/PE~380-400V 50-60Hz, L=3/PE~415V 50-60Hz, M=3/PE~440V 60Hz, P=1/N/PE~220-  
230V 50-60Hz, R=2/PE~220-240V 50-60Hz,

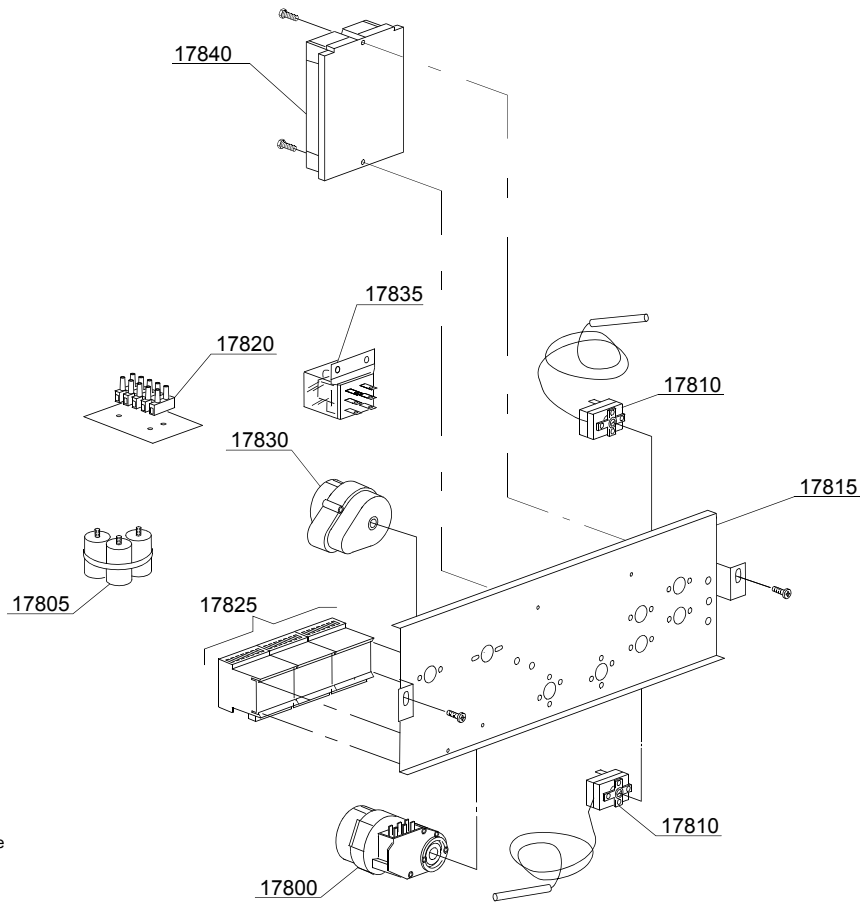

04\_018\_e

## Spare parts

ID	P-code	SN from	SN to	Mod.	Acces.	Volt	Description
<b>Module:Electric control components</b>							
17800	10708/B		-			A	120" timer - 220Vac 60Hz
17800	10708/N		-			A	90" timer with thermostop - 230Vac 50Hz
17805	15149		-				Low noise filter
17810	10707/1		-				0-90°C thermostat
17815	575906		-				Electric components panel
17820	15119		-				Terminal board
17825	15086		-				Contactora 230V 50/60Hz 4C
17825	15086/B		-				Contactora 240V 50Hz
17825	15086/T		-				200Vac3N 50/60HZ contactora
17830	16064/A		-		ws		Regeneration timer
17835	15620		-		dp,ws		16A bipolar relay in deviation
17840	50553	4002149	-	em	dp,ws		3 times electronic timer with regeneration

em=ELECTROMECHANICAL SWITCHES, uw=LOWER AND UPPER WASHING, i=INSULATED MODEL

38R=38R

bp=BOOSTER PUMP, dvgw=DVGW, ws=WATER SOFTNER, dd=DETERGENT DISPENSER, dp=DRAIN PUMP

A=3/N/PE~380-400V 50-60Hz, D=3/PE~200-210V 50-60Hz, F=2/PE~220-240V 50-60Hz, G=3/N/PE~415V 50-60Hz, H=3/PE~220-230V 50-60Hz, K=3/PE~380-400V 50-60Hz, L=3/PE~415V 50-60Hz, M=3/PE~440V 60Hz, P=1/N/PE~220-230V 50-60Hz, R=2/PE~220-240V 50-60Hz,

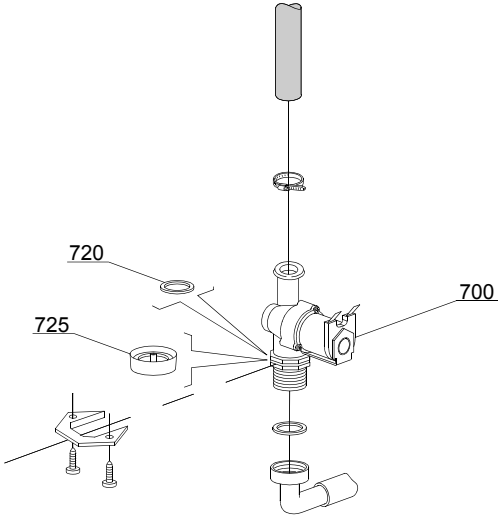

05\_002\_e

## Spare parts

---

ID	P-code	SN from	SN to	Mod.	Acces.	Volt	Description
<b>Module:Solenoid valve group</b>							
700	10703		-	i,em			Single solenoid valve - 220Vac
720	N.C.		-	i,em			Pression reducing valve

em=ELECTROMECHANICAL SWITCHES, uw=LOWER AND UPPER WASHING, i=INSULATED MODEL  
38R=38R

bp=BOOSTER PUMP, dvgw=DVGW, ws=WATER SOFTNER, dd=DETERGENT DISPENSER, dp=DRAIN PUMP  
A=3/N/PE~380-400V 50-60Hz, D=3/PE~200-210V 50-60Hz, F=2/PE~220-240V 50-60Hz, G=3/N/PE~415V 50-60Hz,  
H=3/PE~220-230V 50-60Hz, K=3/PE~380-400V 50-60Hz, L=3/PE~415V 50-60Hz, M=3/PE~440V 60Hz, P=1/N/PE~220-  
230V 50-60Hz, R=2/PE~220-240V 50-60Hz,

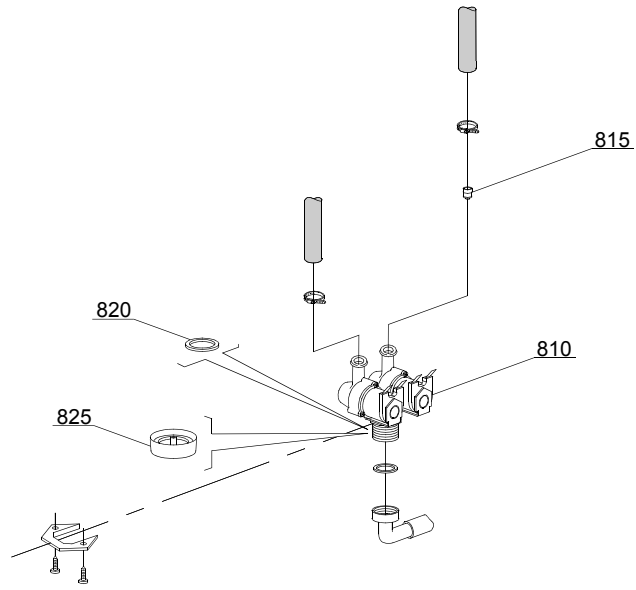

05\_003\_e

## Spare parts

---

ID	P-code	SN from	SN to	Mod.	Acces.	Volt	Description
<b>Module:Solenoid valve group</b>							
810	15098		-	i,em	ws		Double solenoid valve - Ø10 - 220Vac
820	N.C.		-	i,em	ws		Pression reducing valve

em=ELECTROMECHANICAL SWITCHES, uw=LOWER AND UPPER WASHING, i=INSULATED MODEL  
38R=38R

bp=BOOSTER PUMP, dvgw=DVGW, ws=WATER SOFTNER, dd=DETERGENT DISPENSER, dp=DRAIN PUMP  
A=3/N/PE~380-400V 50-60Hz, D=3/PE~200-210V 50-60Hz, F=2/PE~220-240V 50-60Hz, G=3/N/PE~415V 50-60Hz,  
H=3/PE~220-230V 50-60Hz, K=3/PE~380-400V 50-60Hz, L=3/PE~415V 50-60Hz, M=3/PE~440V 60Hz, P=1/N/PE~220-  
230V 50-60Hz, R=2/PE~220-240V 50-60Hz,

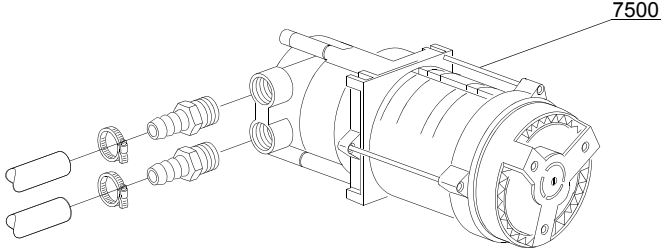

07\_003\_e

## Spare parts

---

ID	P-code	SN from	SN to	Mod.	Acces.	Volt	Description
<b>Module:Booster pump</b>							
7500	15100/D		-	i,em	bp		Booster pump 220/240V

em=ELECTROMECHANICAL SWITCHES, uw=LOWER AND UPPER WASHING, i=INSULATED MODEL

38R=38R

bp=BOOSTER PUMP, dvgw=DVGW, ws=WATER SOFTNER, dd=DETERGENT DISPENSER, dp=DRAIN PUMP

A=3/N/PE~380-400V 50-60Hz, D=3/PE~200-210V 50-60Hz, F=2/PE~220-240V 50-60Hz, G=3/N/PE~415V 50-60Hz, H=3/PE~220-230V 50-60Hz, K=3/PE~380-400V 50-60Hz, L=3/PE~415V 50-60Hz, M=3/PE~440V 60Hz, P=1/N/PE~220-230V 50-60Hz, R=2/PE~220-240V 50-60Hz,

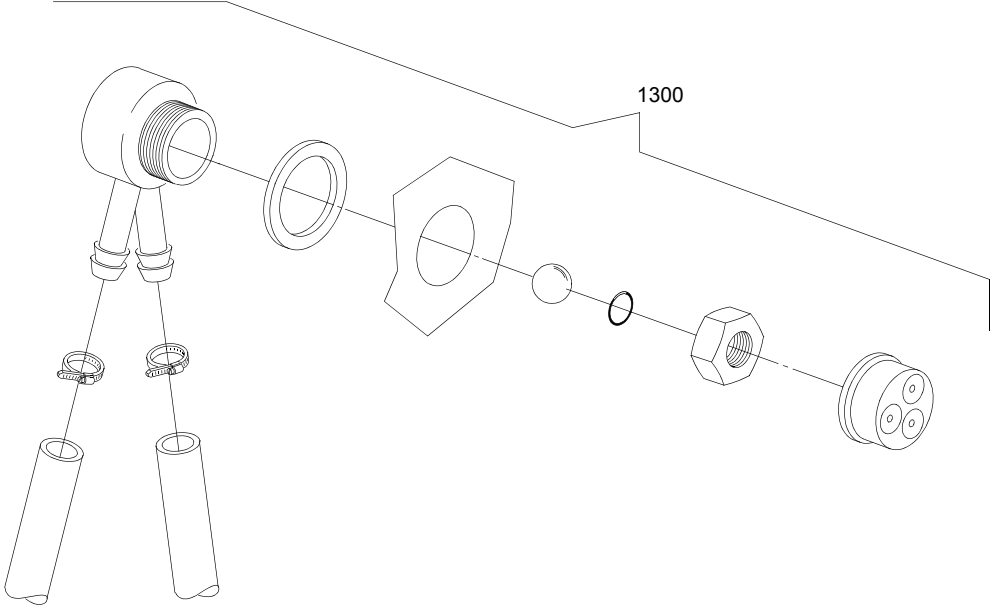

08\_005\_e

## Spare parts

---

ID	P-code	SN from	SN to	Mod.	Acces.	Volt	Description
<b>Module:DVGW</b>							
1300	999900006		-		dvgw		DVGW assembly

em=ELECTROMECHANICAL SWITCHES, uw=LOWER AND UPPER WASHING, i=INSULATED MODEL

38R=38R

bp=BOOSTER PUMP, dvgw=DVGW, ws=WATER SOFTNER, dd=DETERGENT DISPENSER, dp=DRAIN PUMP

A=3/N/PE~380-400V 50-60Hz, D=3/PE~200-210V 50-60Hz, F=2/PE~220-240V 50-60Hz, G=3/N/PE~415V 50-60Hz,  
 H=3/PE~220-230V 50-60Hz, K=3/PE~380-400V 50-60Hz, L=3/PE~415V 50-60Hz, M=3/PE~440V 60Hz, P=1/N/PE~220-  
 230V 50-60Hz, R=2/PE~220-240V 50-60Hz,

09\_001\_e

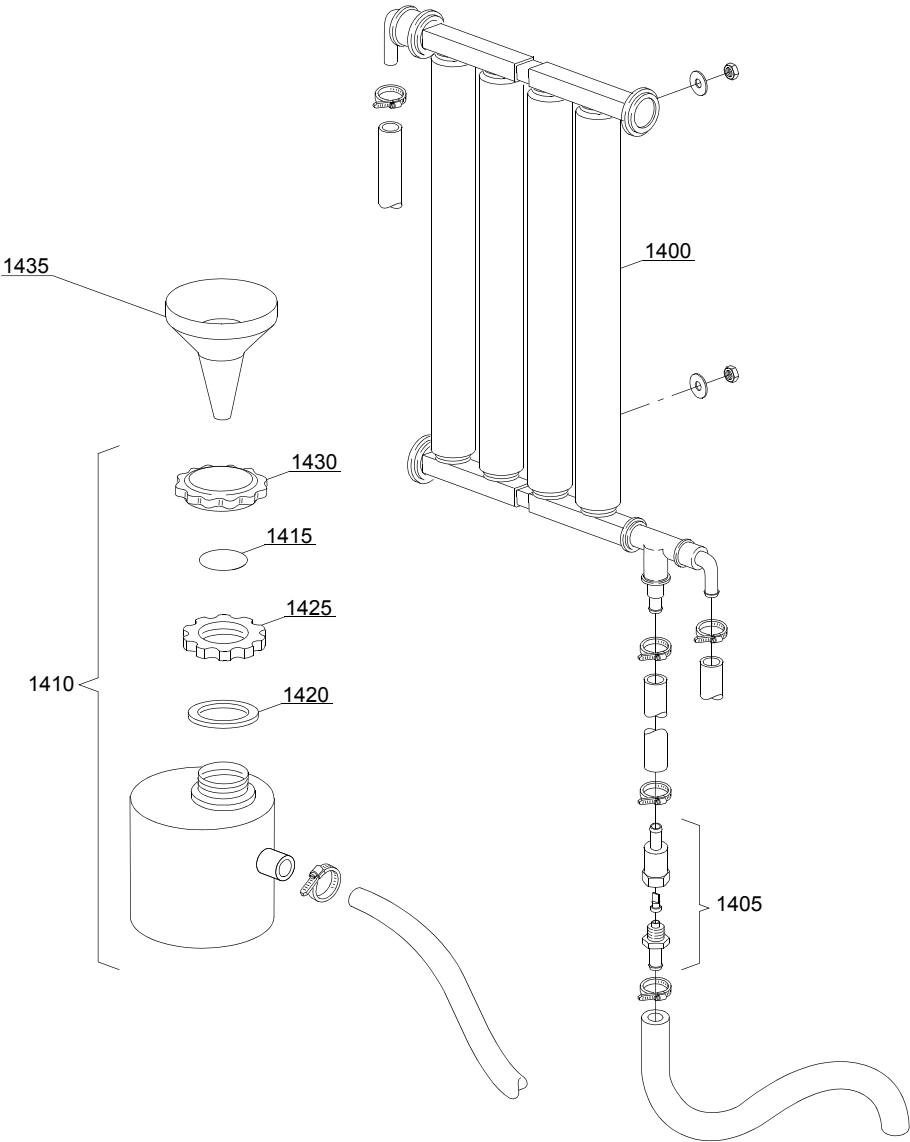

## Spare parts

ID	P-code	SN from	SN to	Mod.	Acces.	Volt	Description
<b>Module: Water softner group</b>							
1400	16066		-		ws		4 elements water softner
1405	16070		-		ws		Nonreturn valve
1410	16065		-		ws		Salt container
1415	16067/A		-		ws		OR O-ring
1420	16067/B		-		ws		O-ring
1425	16067/C		-		ws		Ring nut
1430	16067/D		-		ws		Plug
1435	16082		-		ws		Funnel

em=ELECTROMECHANICAL SWITCHES, uw=LOWER AND UPPER WASHING, i=INSULATED MODEL  
38R=38R

bp=BOOSTER PUMP, dvgw=DVGW, ws=WATER SOFTNER, dd=DETERGENT DISPENSER, dp=DRAIN PUMP  
A=3/N/PE~380-400V 50-60Hz, D=3/PE~200-210V 50-60Hz, F=2/PE~220-240V 50-60Hz, G=3/N/PE~415V 50-60Hz,  
H=3/PE~220-230V 50-60Hz, K=3/PE~380-400V 50-60Hz, L=3/PE~415V 50-60Hz, M=3/PE~440V 60Hz, P=1/N/PE~220-  
230V 50-60Hz, R=2/PE~220-240V 50-60Hz,

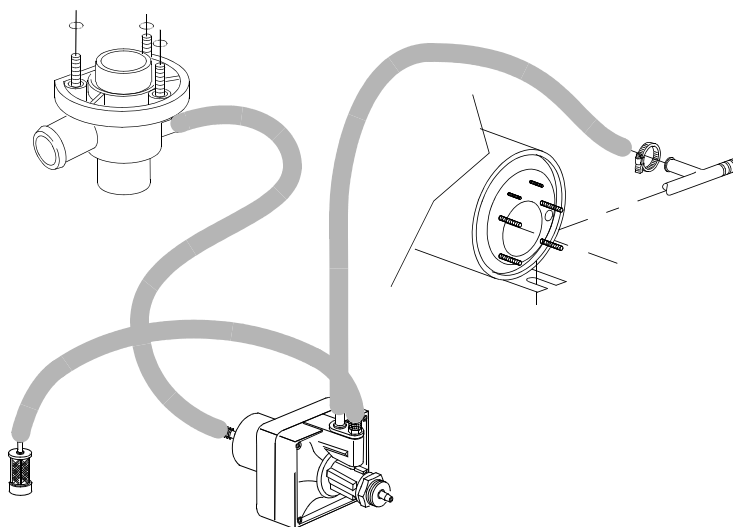
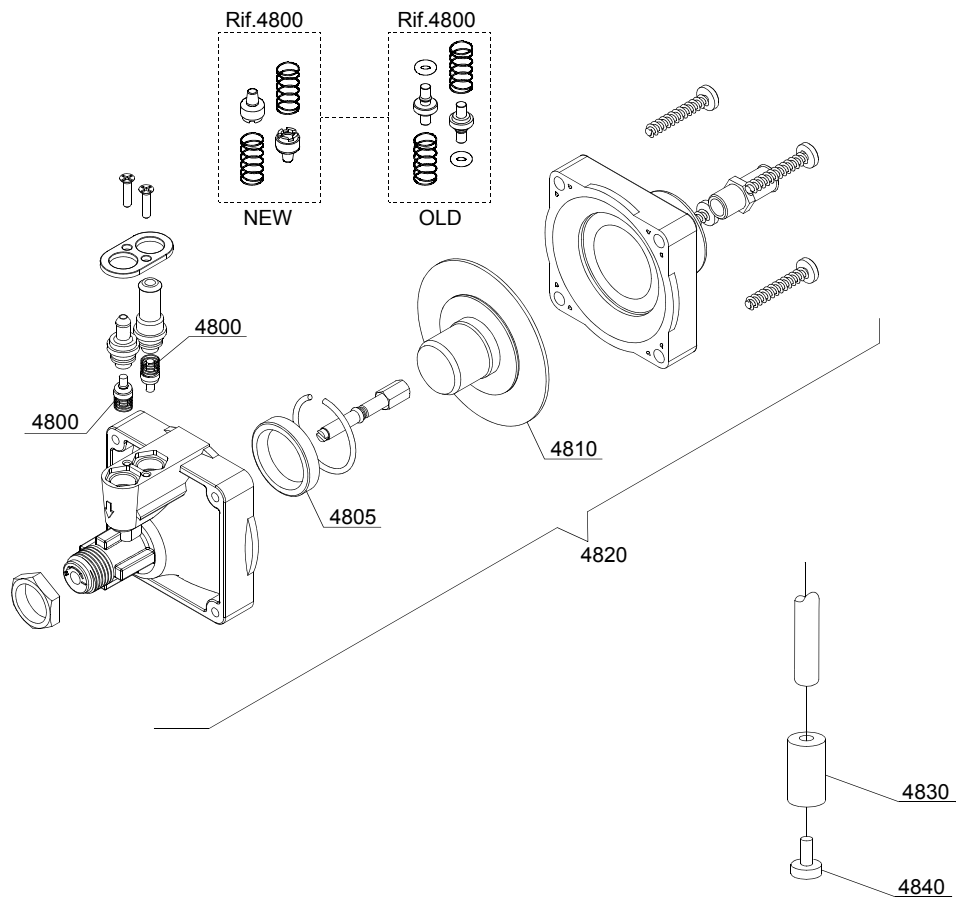

10\_004\_e

## Spare parts

ID	P-code	SN from	SN to	Mod.	Acces.	Volt	Description
<b>Module: Rinse aid dispenser group</b>							
4800	10805		-				Tecnopro non return valve
4805	10806		-				Ø22 O-ring
4810	10807		-				Membrane
4820	10799		-				Rinse aid dispenser
4830	12525		-				Counter-weight
4840	15058		-				Small filter (minimum 3 pieces)

em=ELECTROMECHANICAL SWITCHES, uw=LOWER AND UPPER WASHING, i=INSULATED MODEL

38R=38R

bp=BOOSTER PUMP, dvgw=DVGW, ws=WATER SOFTNER, dd=DETERGENT DISPENSER, dp=DRAIN PUMP

A=3/N/PE~380-400V 50-60Hz, D=3/PE~200-210V 50-60Hz, F=2/PE~220-240V 50-60Hz, G=3/N/PE~415V 50-60Hz, H=3/PE~220-230V 50-60Hz, K=3/PE~380-400V 50-60Hz, L=3/PE~415V 50-60Hz, M=3/PE~440V 60Hz, P=1/N/PE~220-230V 50-60Hz, R=2/PE~220-240V 50-60Hz,

11\_002\_e

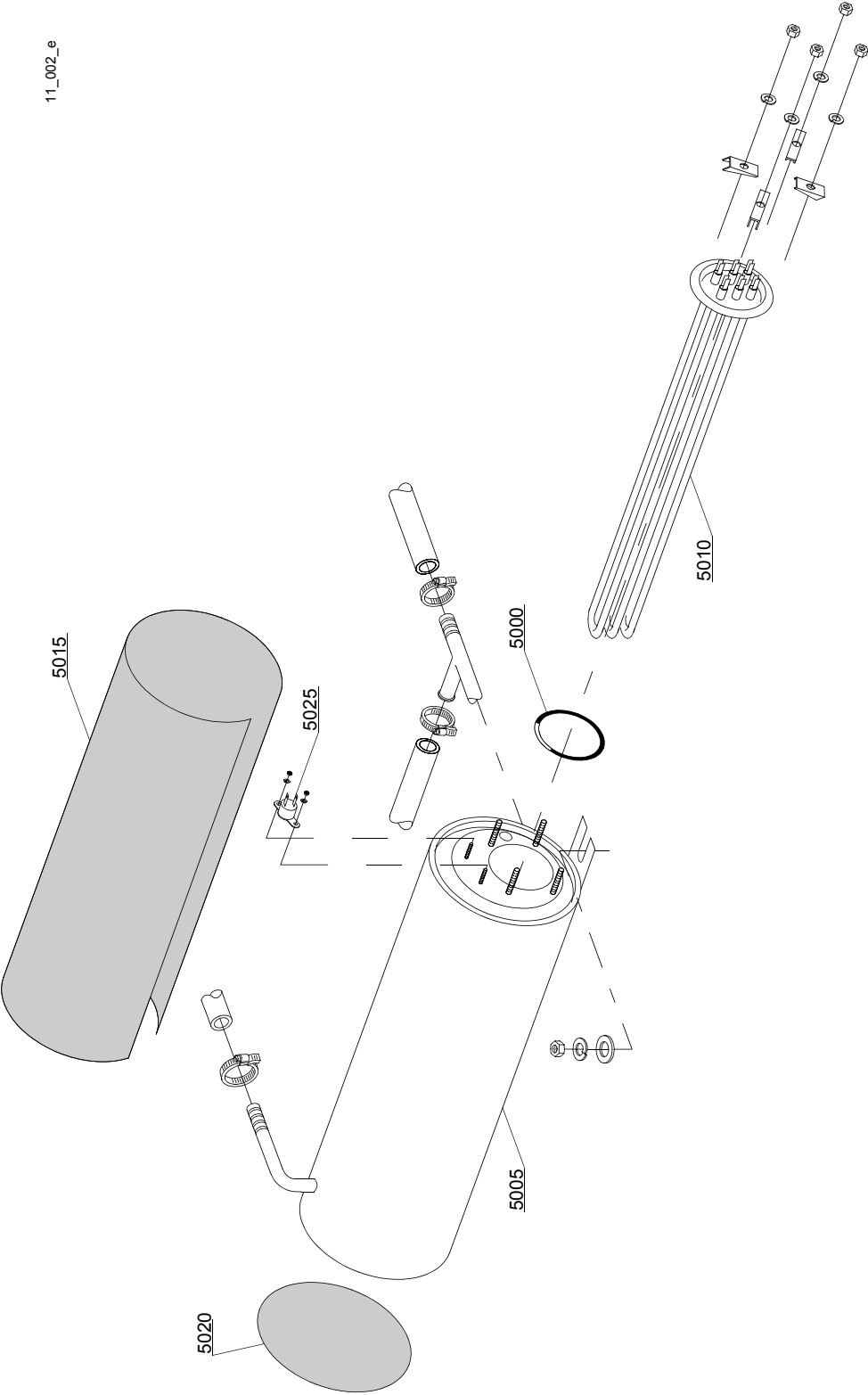

## Spare parts

ID	P-code	SN from	SN to	Mod.	Acces.	Volt	Description
<b>Module:Boiler group</b>							
5000	13005		-	i			OR 151 NBR O-ring (minimum 5 pieces)
5005	150905		-	i			Boiler
5005	150917		-	i			AISI 314 boiler
5010	15089		-	i			4,5/4,9KW 230/240V 3 heating element
5010	15046		-	i			3/3,27KW 230/240V 3 heating element
5015	15066		-	i			Insulation boiler
5020	15205		-	i			Ø160 End piece (minimum 2 pieces)
5025	15550		-	i			Safety thermostat

em=ELECTROMECHANICAL SWITCHES, uw=LOWER AND UPPER WASHING, i=INSULATED MODEL  
38R=38R

bp=BOOSTER PUMP, dvgw=DVGW, ws=WATER SOFTNER, dd=DETERGENT DISPENSER, dp=DRAIN PUMP  
A=3/N/PE~380-400V 50-60Hz, D=3/PE~200-210V 50-60Hz, F=2/PE~220-240V 50-60Hz, G=3/N/PE~415V 50-60Hz,  
H=3/PE~220-230V 50-60Hz, K=3/PE~380-400V 50-60Hz, L=3/PE~415V 50-60Hz, M=3/PE~440V 60Hz, P=1/N/PE~220-  
230V 50-60Hz, R=2/PE~220-240V 50-60Hz,

12\_007\_e

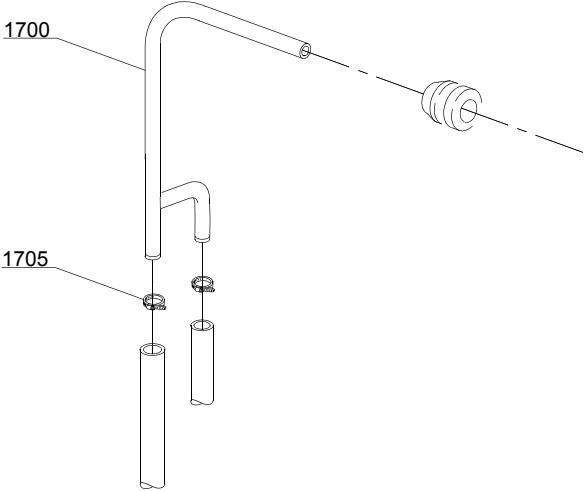

## Spare parts

ID	P-code	SN from	SN to	Mod.	Acces.	Volt	Description
<b>Module:Connection group</b>							
1700	15045/B		-				3 ways connection
1705	11807		-				12/22 clamp (minimum 3 pieces)

em=ELECTROMECHANICAL SWITCHES, uw=LOWER AND UPPER WASHING, i=INSULATED MODEL  
38R=38R

bp=BOOSTER PUMP, dvgw=DVGW, ws=WATER SOFTNER, dd=DETERGENT DISPENSER, dp=DRAIN PUMP  
A=3/N/PE~380-400V 50-60Hz, D=3/PE~200-210V 50-60Hz, F=2/PE~220-240V 50-60Hz, G=3/N/PE~415V 50-60Hz,  
H=3/PE~220-230V 50-60Hz, K=3/PE~380-400V 50-60Hz, L=3/PE~415V 50-60Hz, M=3/PE~440V 60Hz, P=1/N/PE~220-  
230V 50-60Hz, R=2/PE~220-240V 50-60Hz,

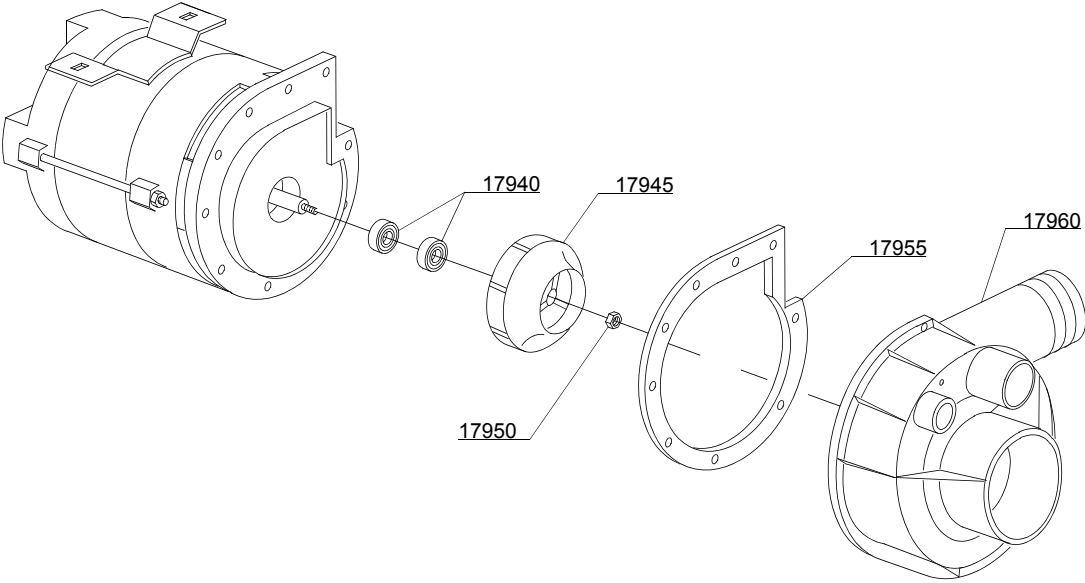
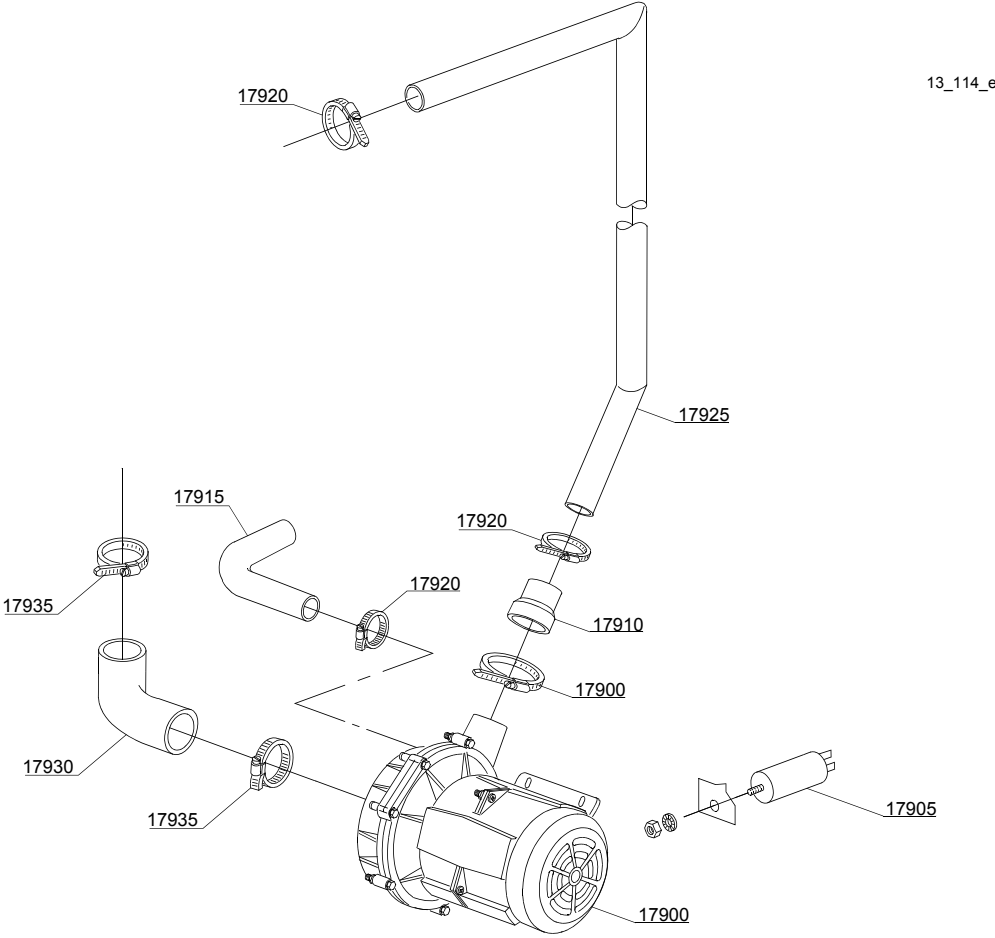

## Spare parts

ID	P-code	SN from	SN to	Mod.	Acces.	Volt	Description
<b>Module: Wash pump</b>							
17900	15908/D		-	uw		A	1Hp wash pump - 220/240Vac 50Hz
17905	15081		-	uw			12,5 uF condenser
17910	15034		-	uw			Reduction pipe coupling
17915	15033		-	uw			Lower wash delivery pipe
17920	11806		-	uw			25/40 clamp (minimum 2 pieces)
17925	575000		-	uw			Top wash ramp
17930	15032/A		-	uw			Suction pipe coupling
17935	11824		-	uw			50/70 clamp (minimum 2 pieces)
17940	15080/C		-	uw			Rotating seals
17945	15079/B		-	uw			Pump rotor
17950	11724		-	uw			M6 stainless steel nut
17955	15079/D		-	uw			O-ring
17960	15031/E		-	uw			Scroll

em=ELECTROMECHANICAL SWITCHES, uw=LOWER AND UPPER WASHING, i=INSULATED MODEL  
38R=38R

bp=BOOSTER PUMP, dvgw=DVGW, ws=WATER SOFTNER, dd=DETERGENT DISPENSER, dp=DRAIN PUMP

A=3/N/PE~380-400V 50-60Hz, D=3/PE~200-210V 50-60Hz, F=2/PE~220-240V 50-60Hz, G=3/N/PE~415V 50-60Hz,  
H=3/PE~220-230V 50-60Hz, K=3/PE~380-400V 50-60Hz, L=3/PE~415V 50-60Hz, M=3/PE~440V 60Hz, P=1/N/PE~220-  
230V 50-60Hz, R=2/PE~220-240V 50-60Hz,

14\_002\_e

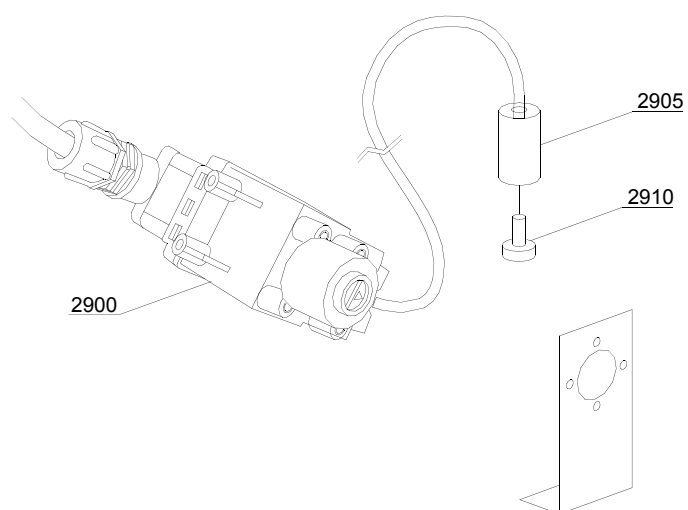
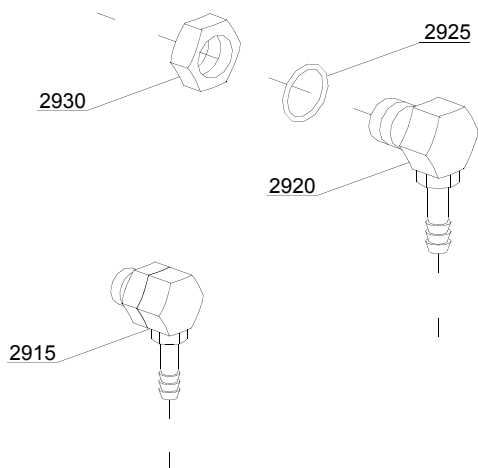

## Spare parts

ID	P-code	SN from	SN to	Mod.	Acces.	Volt	Description
<b>Module:Dosing detergent group</b>							
2900	15108/L		-		dd		Lang detergent pump
2905	12525		-		dd		Counter-weight
2910	15058		-		dd		Small filter (minimum 3 pieces)
2915	15123		-		dd		Complect plastic injector
2920	15148		-		dd		Steel injector
2925	15159		-		dd		OR O-ring (minimum 2 pieces)
2930	10200205		-		dd		M12x1 stainless steel nut (minimum 2 pieces)

em=ELECTROMECHANICAL SWITCHES, uw=LOWER AND UPPER WASHING, i=INSULATED MODEL

38R=38R

bp=BOOSTER PUMP, dvgw=DVGW, ws=WATER SOFTNER, dd=DETERGENT DISPENSER, dp=DRAIN PUMP

A=3/N/PE~380-400V 50-60Hz, D=3/PE~200-210V 50-60Hz, F=2/PE~220-240V 50-60Hz, G=3/N/PE~415V 50-60Hz, H=3/PE~220-230V 50-60Hz, K=3/PE~380-400V 50-60Hz, L=3/PE~415V 50-60Hz, M=3/PE~440V 60Hz, P=1/N/PE~220-230V 50-60Hz, R=2/PE~220-240V 50-60Hz,

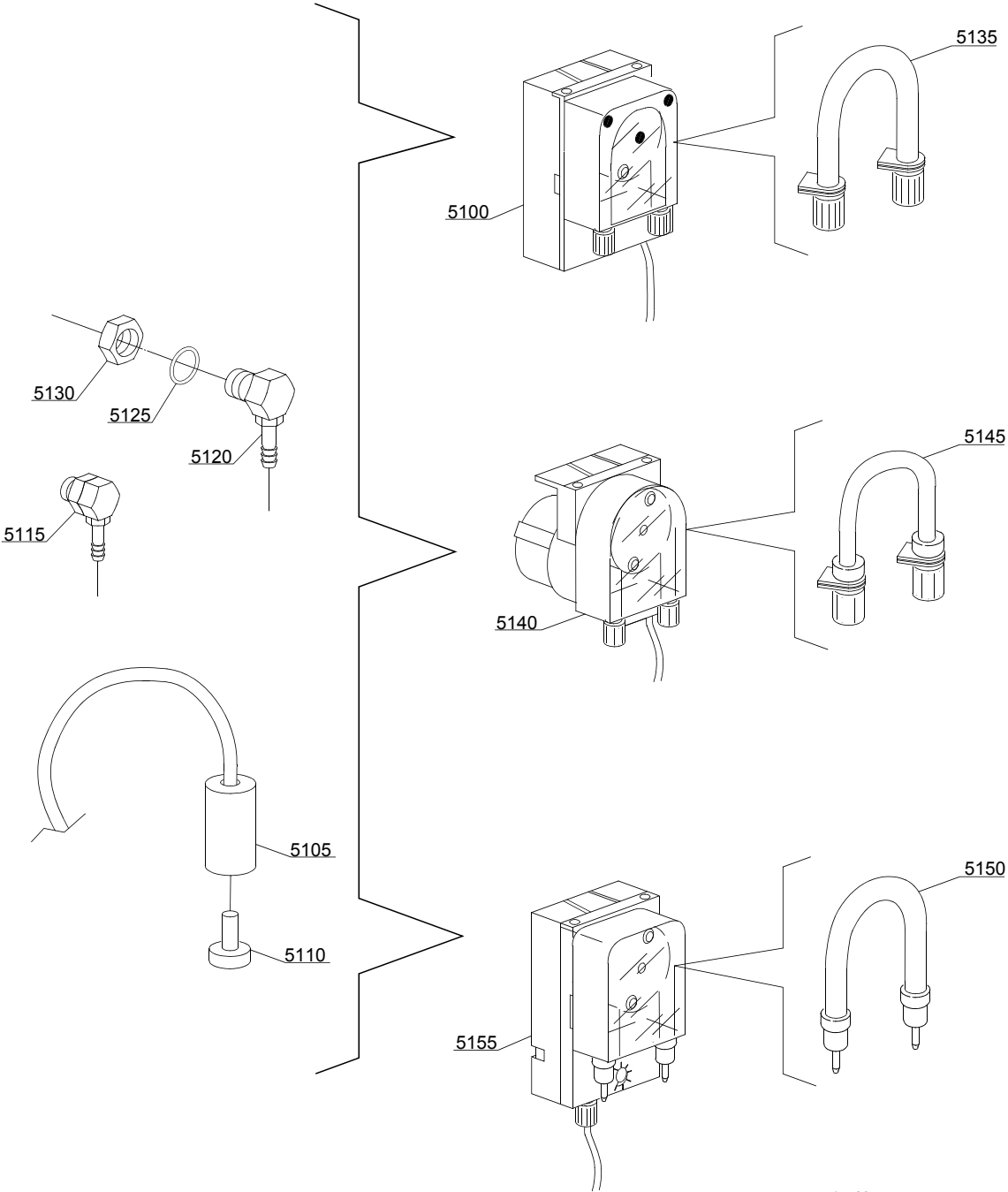

14\_004\_e

## Spare parts

ID	P-code	SN from	SN to	Mod.	Acces.	Volt	Description
<b>Module:Dosing detergent group</b>							
5100	15985		-	i,em	dd		Seko detergent pump
5105	12525		-	i,em	dd		Counter-weight
5110	15058		-	i,em	dd		Small filter (minimum 3 pieces)
5115	15123		-	i,em	dd		Complet plastic injector
5120	15148		-	i,em	dd		Steel injector
5125	15159		-	i,em	dd		OR O-ring (minimum 2 pieces)
5130	10200205		-	i,em	dd		M12x1 stainless steel nut (minimum 2 pieces)
5135	15185		-	i,em	dd		Seko thermoplastic pipe
5140	15985		-	i,em	dd		Germac detergent pump
5145	15108/E		-	i,em	dd		Germac thermoplastic pipe
5150	15985/A			i,em	dd		Plas Cont thermoplastic pipe
5155	15985			i,em	dd		Plas Cont detergent pump

em=ELECTROMECHANICAL SWITCHES, uw=LOWER AND UPPER WASHING, i=INSULATED MODEL

38R=38R

bp=BOOSTER PUMP, dvgw=DVGW, ws=WATER SOFTNER, dd=DETERGENT DISPENSER, dp=DRAIN PUMP

A=3/N/PE~380-400V 50-60Hz, D=3/PE~200-210V 50-60Hz, F=2/PE~220-240V 50-60Hz, G=3/N/PE~415V 50-60Hz, H=3/PE~220-230V 50-60Hz, K=3/PE~380-400V 50-60Hz, L=3/PE~415V 50-60Hz, M=3/PE~440V 60Hz, P=1/N/PE~220-230V 50-60Hz, R=2/PE~220-240V 50-60Hz,

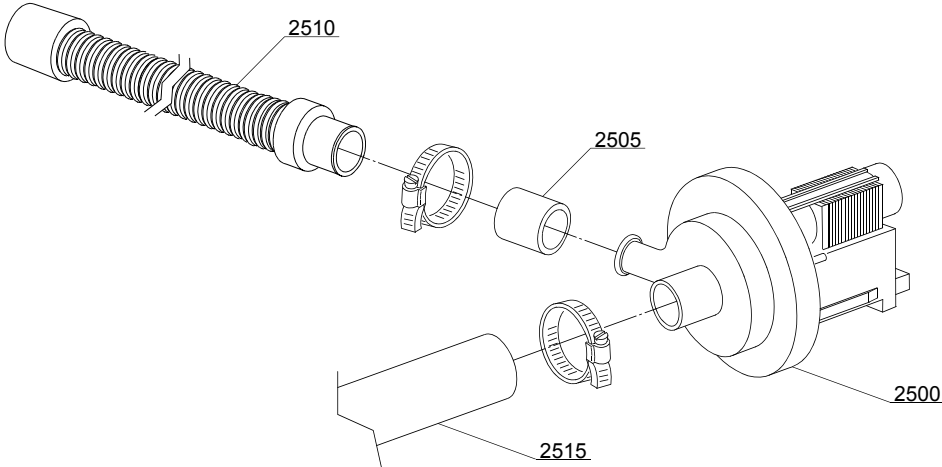

15\_004\_e

## Spare parts

ID	P-code	SN from	SN to	Mod.	Acces.	Volt	Description
<b>Module: Drain pump group</b>							
2500	15101		-		dp		Drain pump 220/240V 50Hz
2505	15101/D		-		dp		Pipe fitting (minimum 3 pieces)
2510	10727		-		dp		Drain pipe
2515	18767		-		dp		Drain coude/pump connection pipe

em=ELECTROMECHANICAL SWITCHES, uw=LOWER AND UPPER WASHING, i=INSULATED MODEL

38R=38R

bp=BOOSTER PUMP, dvgw=DVGW, ws=WATER SOFTNER, dd=DETERGENT DISPENSER, dp=DRAIN PUMP

A=3/N/PE~380-400V 50-60Hz, D=3/PE~200-210V 50-60Hz, F=2/PE~220-240V 50-60Hz, G=3/N/PE~415V 50-60Hz, H=3/PE~220-230V 50-60Hz, K=3/PE~380-400V 50-60Hz, L=3/PE~415V 50-60Hz, M=3/PE~440V 60Hz, P=1/N/PE~220-230V 50-60Hz, R=2/PE~220-240V 50-60Hz,

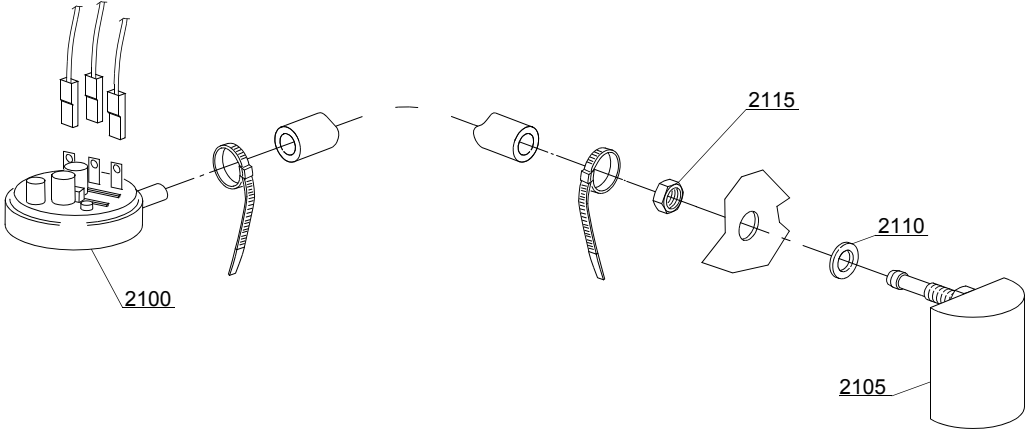

16\_001\_e

## Spare parts

ID	P-code	SN from	SN to	Mod.	Acces.	Volt	Description
<b>Module:Pressure switch group with air trap</b>							
2100	10706/A		-	i,em			47-27 pressure switch
2105	135911/D	4020618	-	i,em			Grey air trap assembly
2110	13301		-	i,em			O-ring (minimum 10 pieces)
2115	11702		-	i,em			M8 stainless steel nut (minimum 10 pieces)

em=ELECTROMECHANICAL SWITCHES, uw=LOWER AND UPPER WASHING, i=INSULATED MODEL

38R=38R

bp=BOOSTER PUMP, dvgw=DVGW, ws=WATER SOFTNER, dd=DETERGENT DISPENSER, dp=DRAIN PUMP

A=3/N/PE~380-400V 50-60Hz, D=3/PE~200-210V 50-60Hz, F=2/PE~220-240V 50-60Hz, G=3/N/PE~415V 50-60Hz, H=3/PE~220-230V 50-60Hz, K=3/PE~380-400V 50-60Hz, L=3/PE~415V 50-60Hz, M=3/PE~440V 60Hz, P=1/N/PE~220-230V 50-60Hz, R=2/PE~220-240V 50-60Hz,

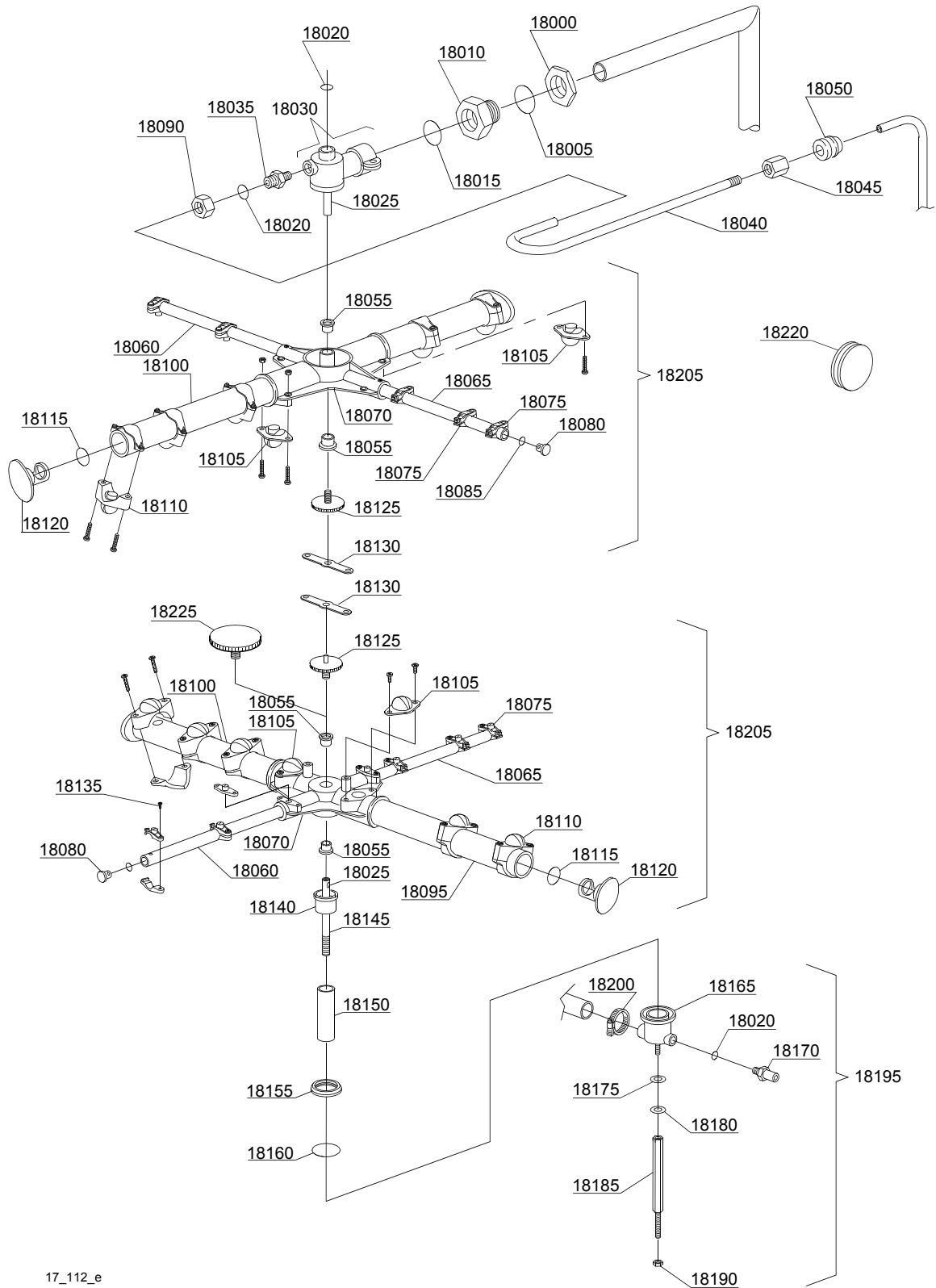

17\_112\_e

## Spare parts

ID	P-code	SN from	SN to	Mod.	Acces.	Volt	Description
<b>Module:Turret group with rotating arms</b>							
18000	15042/A		-	uw			Nut
18005	13008		-	uw			OR 147 NBR O-ring (minimum 5 pieces)
18010	15042		-	uw			1" 1/4 ring nut
18015	13004		-	uw			OR 3137 NBR O-ring (minimum 3 pieces)
18020	13003		-	uw			OR 112 NBR O-ring (minimum 10 pieces)
18025	15300		-	uw			Ø10x51 lower/top rinse axle
18030	15069/C		-	uw			Top wash/rinse distributor assembly
18035	12006		-	uw			Ø10 rinse pipe fitting
18040	15045		-	uw			Top rinse ramp
18045	12526		-	uw			Stainless steel nut coupling
18050	13304		-	uw			Pipe-pass O-ring
18055	13319		-	uw			Sliding washer (minimum 2 pieces)
18060	15575		-	uw			Right rinse pipe
18065	15576		-	uw			Left rinse pipe
18070	10209		-	uw			4 ways big rotor
18075	12528		-	uw			Ø10 complet rinse nozzle (minimum 2 pieces)
18080	12532		-	uw			Ø10 plastic plug (minimum 3 pieces)
18085	13016		-	uw			2018 OR 103 NBR O-ring (minimum 10 pieces)
18090	12006/A		-	uw			Ø10 pipe fitting 3/8x3,5 nut 19 hexagonal
18095	15571		-	uw			Ø28 right wash pipe
18100	15572		-	uw			Ø28 left wash pipe
18105	10218		-	uw			Ø28 opened plane nozzle (minimum 2 pieces)
18110	10211		-	uw			Ø28 raised nozzle (minimum 2 pieces)
18115	13018		-	uw			OR 2087 NBR O-ring (minimum 10 pieces)
18120	10257		-	uw			Ø28 plastic plug (minimum 3 pieces)
18125	11101/I		-	uw			Stainless steel group fixing screw
18130	10210		-	uw			Blocking ring nut rotor plaque
18135	11121		-	uw			TCB M4x8 steel screw (minimum 20 pieces)

em=ELECTROMECHANICAL SWITCHES, uw=LOWER AND UPPER WASHING, i=INSULATED MODEL  
38R=38R

bp=BOOSTER PUMP, dvgw=DVGW, ws=WATER SOFTNER, dd=DETERGENT DISPENSER, dp=DRAIN PUMP  
A=3/N/PE~380-400V 50-60Hz, D=3/PE~200-210V 50-60Hz, F=2/PE~220-240V 50-60Hz, G=3/N/PE~415V 50-60Hz,  
H=3/PE~220-230V 50-60Hz, K=3/PE~380-400V 50-60Hz, L=3/PE~415V 50-60Hz, M=3/PE~440V 60Hz, P=1/N/PE~220-  
230V 50-60Hz, R=2/PE~220-240V 50-60Hz,

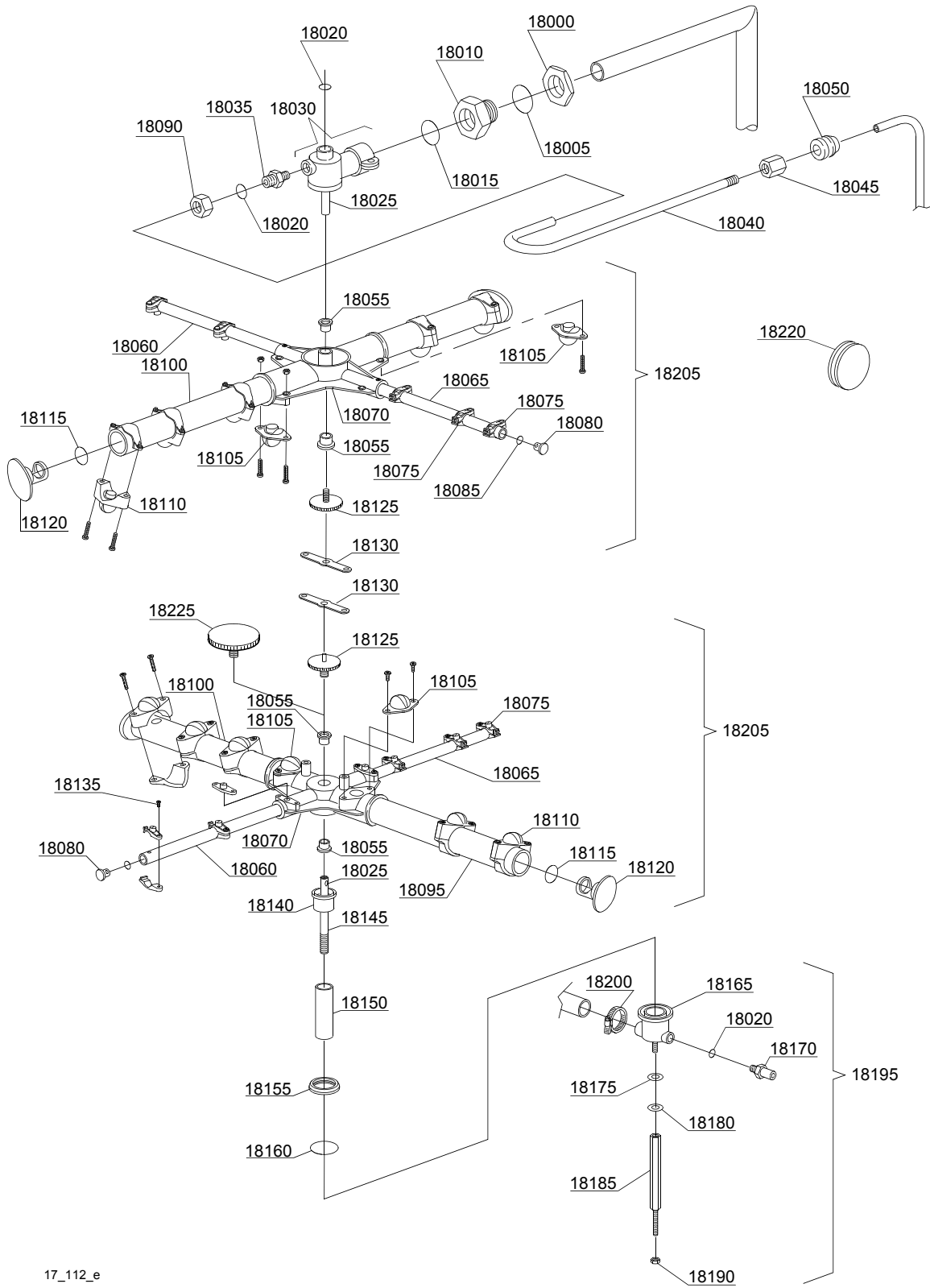

17\_112\_e

## Spare parts

ID	P-code	SN from	SN to	Mod.	Acces.	Volt	Description
<b>Module:Turret group with rotating arms</b>							
18140	15040/A		-	uw			Lower wash bell-shape
18145	15303		-	uw			Short lower rinse extension
18150	15039/A		-	uw			Lower wash stainless steel pipe coupling
18155	15038		-	uw			Ring nut connection
18160	13006		-	uw			OR 3156 O-ring (minimum 10 pieces)
18165	15041/A		-	uw			Grey wash/rinse lower distributor
18170	12506		-	uw			Ø10 rubber-holder (minimum 2 pieces)
18175	13313		-	uw			8x24x2 O-ring (minimum 5 pieces)
18180	11185		-	uw			8x16 steel plane washer (minimum 20 pieces)
18185	575001		-	uw			Lower turret tie rod
18190	11702		-	uw			M8 stainless steel nut (minimum 10 pieces)
18195	15909		-	uw			Lower wash water distributor
18200	11809		-	uw			30/45 clamp (minimum 2 pieces)
18205	15956		-	uw			Ø28 wash/rinse group
18210	10213		-	uw			Ø10 opened plane nozzle (minimum 2 pieces)
18215	10217		-	uw			Ø10 closed plane nozzle (minimum 2 pieces)
18220	13316/A		-	uw			DVGW hole O-ring
18225	11101/M		-	uw			Fixing handle for rotor

em=ELECTROMECHANICAL SWITCHES, uw=LOWER AND UPPER WASHING, i=INSULATED MODEL

38R=38R

bp=BOOSTER PUMP, dvgw=DVGW, ws=WATER SOFTNER, dd=DETERGENT DISPENSER, dp=DRAIN PUMP

A=3/N/PE~380-400V 50-60Hz, D=3/PE~200-210V 50-60Hz, F=2/PE~220-240V 50-60Hz, G=3/N/PE~415V 50-60Hz, H=3/PE~220-230V 50-60Hz, K=3/PE~380-400V 50-60Hz, L=3/PE~415V 50-60Hz, M=3/PE~440V 60Hz, P=1/N/PE~220-230V 50-60Hz, R=2/PE~220-240V 50-60Hz,