

HD22 and HD30 Service Parts

This is the list of service parts and wiring diagrams for all versions of these two hotel dispensers.

Pay close attention to the voltage and/or cycles to be sure of ordering the correct part.

Table of Contents

Front and Top Panels	Page 2
HD30B & HD22B Front Panel	Page 3
HD30N and HD30W Front Panel & Related Parts	Page 4
Side, Back and Interior Panels	Page 5
Dispensing Components	Page 6
Ice Chute Mechanism	Page 7
Ice Catch Pan	Page 8
Control Box	Page 9
Wiring Diagram, 115 volt, 60 Hz Basic and Water Station	Page 10
Schematic Diagram, Basic and Water Station Models	Page 11
Wiring Diagram, 230 volt, 50 Hz Basic	Page 12
Wiring Diagram for Coin Mechanism Model	Page 13
Schematic Diagram for Coin Mechanism Model	Page 14

HD22 and HD30 Service Parts

Front and Top Panels

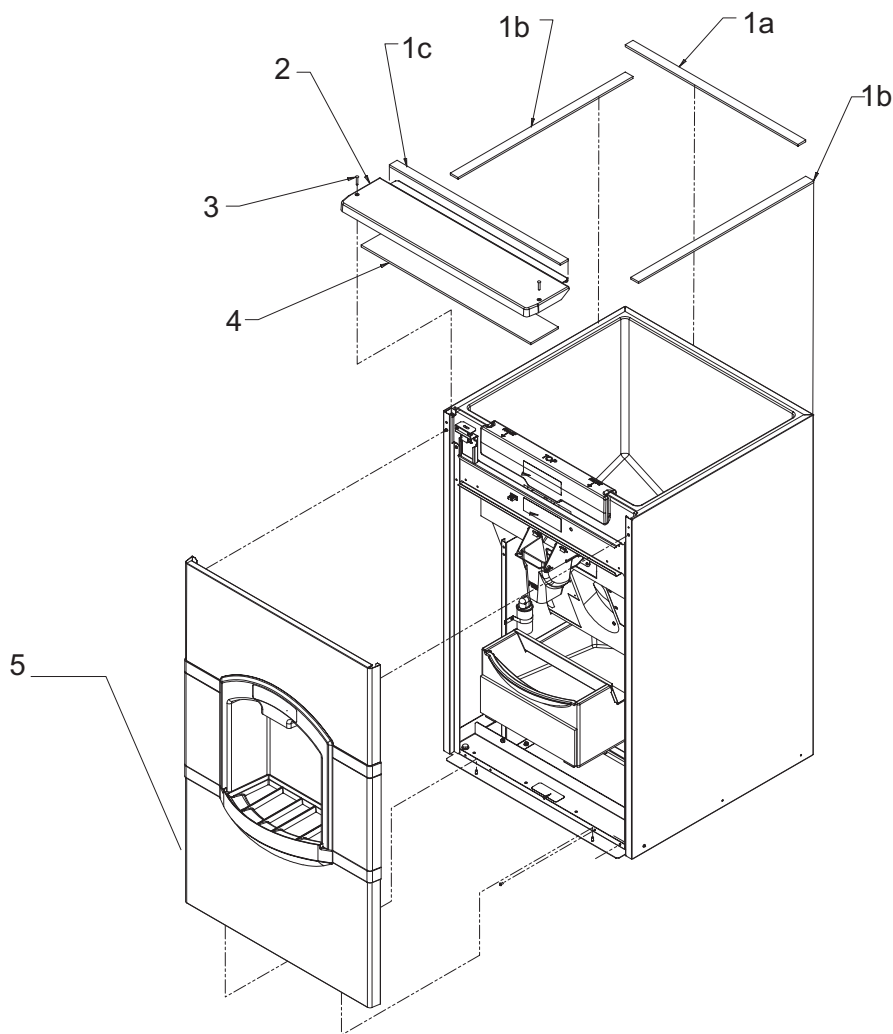

Item Number	Part Number	Description	5		
				A38318-021	HD30B or HD30W front panel with side flanges
				A38318-023	HD30N front panel with side flanges
				A38319-021	HD22 front panel with side flanges
1	19-0503-04	Gasket tape, order by ft.			
1a		Use 27.5" for HD30, 19.5" for HD22			
1b		Use 27.88"			
1c		Use 27.25" for HD30, 19.25" for HD22			
2	02-3997-01	HD30 top panel			
	02-3997-03	HD22 top panel			
3	03-1735-01	Top panel screw			
4	02-3998-01	HD30 panel insulation			
	02-3998-02	HD22 panel insulation			

HD22 and HD30 Service Parts

HD30B & HD22B Front Panel

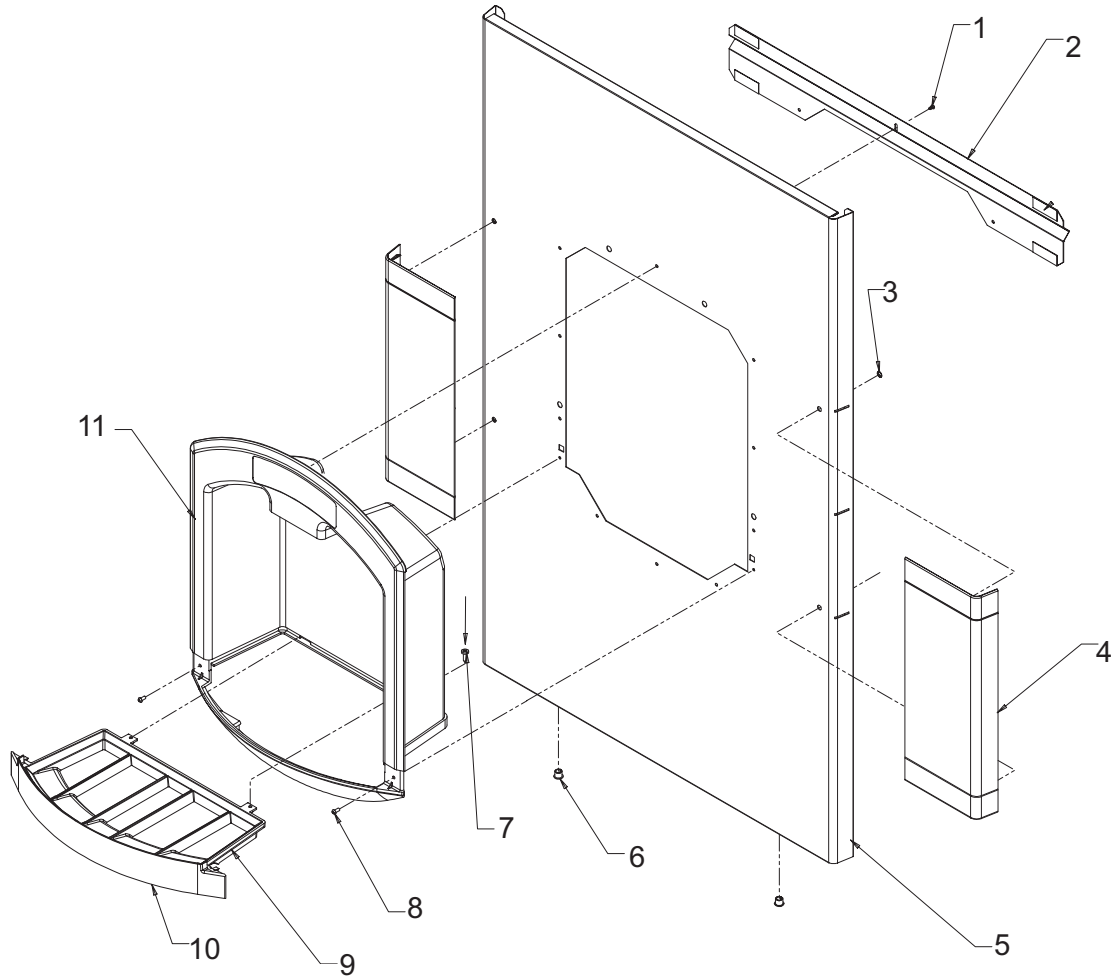

Item Number	Part Number	Description	Item Number	Part Number	Description
1	03-3836-01	Screw	11a	02-3971-01	HD22, HD30B, HD30N dispense housing
2	A38357-001	HD30 stiffener	11b	02-3971-03	HD30W dispense housing
	A38357-002	HD22 stiffener			
3	03-1731-02	Retainer			
4	02-3973-01	HD30B side flange			
	02-3973-02	HD22 side flange			
5	A38318-021	HD30 Front panel*			
	A38319-021	HD22 Front panel*			
6	12-1213-04	Snap bushing			
7	03-1404-12	Screw			
8	03-1531-01	Screw			
9	19-0503-11	Foam gasket, 6" per side			
10	02-3972-01	Grill			

* includes items 1 thru 4

HD22 and HD30 Service Parts

HD30N and HD30W Front Panel & Related Parts

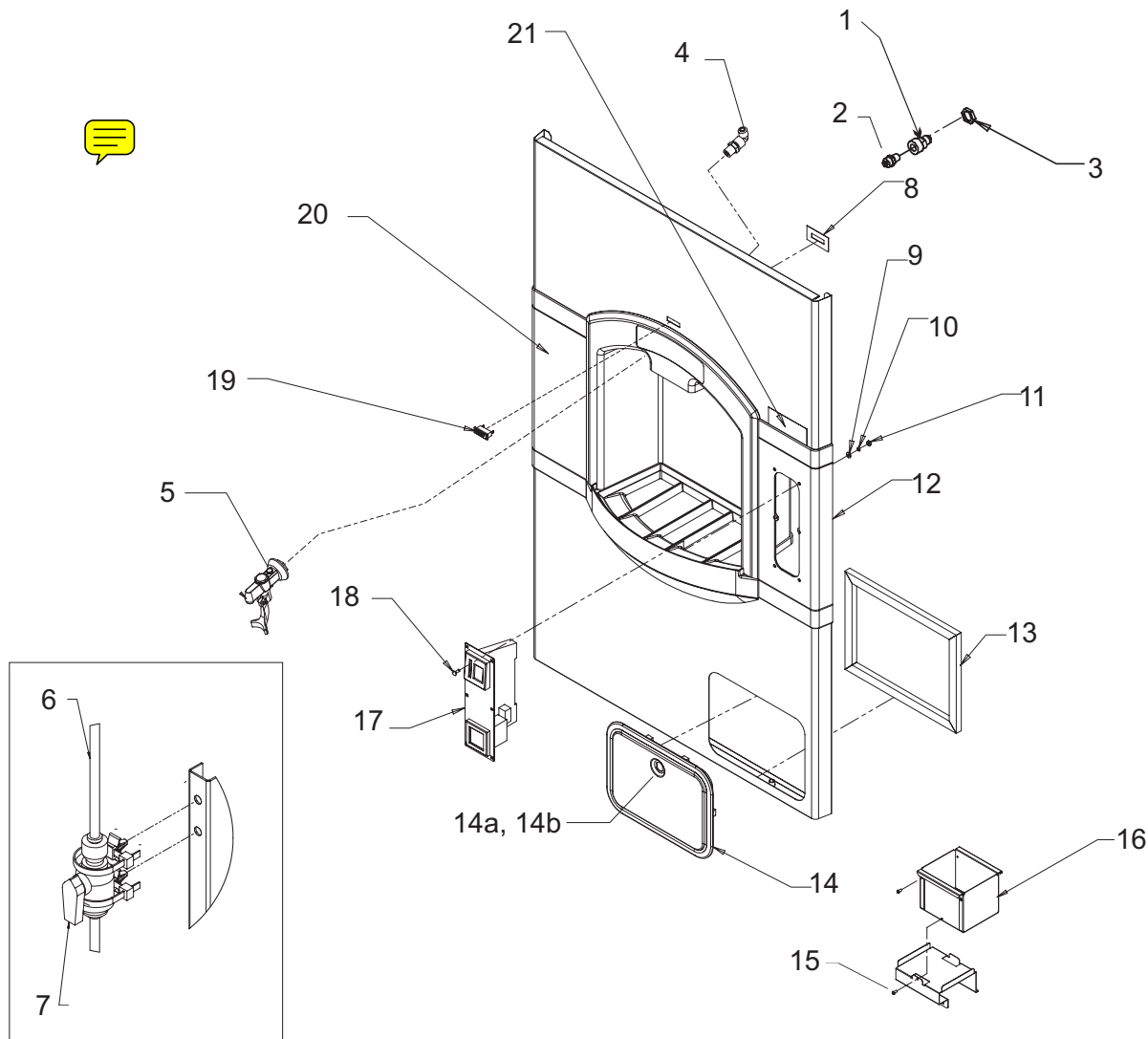

Item Number	Part Number	Description	Item Number	Part Number	Description
1	16-0835-01	Water inlet fitting	12	02-3973-05	Right side flange for coin mech model
2	16-1039-01	Straight connector	13	01-1295-01	Door shim
3	03-1394-01	Pal nut	14	12-2896-02	Door and lock
4	16-1104-01	Male elbow connector	14a	12-2896-26	Lock and key
5	02-3990-01	Water faucet	14b	12-2896-27	Key
6	13-0895-01	Tubing, order per ft	15	03-1531-01	Coin box screw
7	16-1105-01	Shut off valve	16	A38438-001	Coin box
8	A38462-001	Indicator light backing	17	12-2896-01	Coin mechanism
9	03-1407-02	Washer for coin mech		12-2896-25	Coin switch
10	03-1410-07	Lockwasher	18	12-2896-03	Mounting screw
11	03-1406-04	Hex nut (8-32)	19	12-2908-01	Ready light
			20	02-3973-01	HD30 left side flange
			21	17-2970-01	Coin mech label

HD22 and HD30 Service Parts

Side, Back and Interior Panels

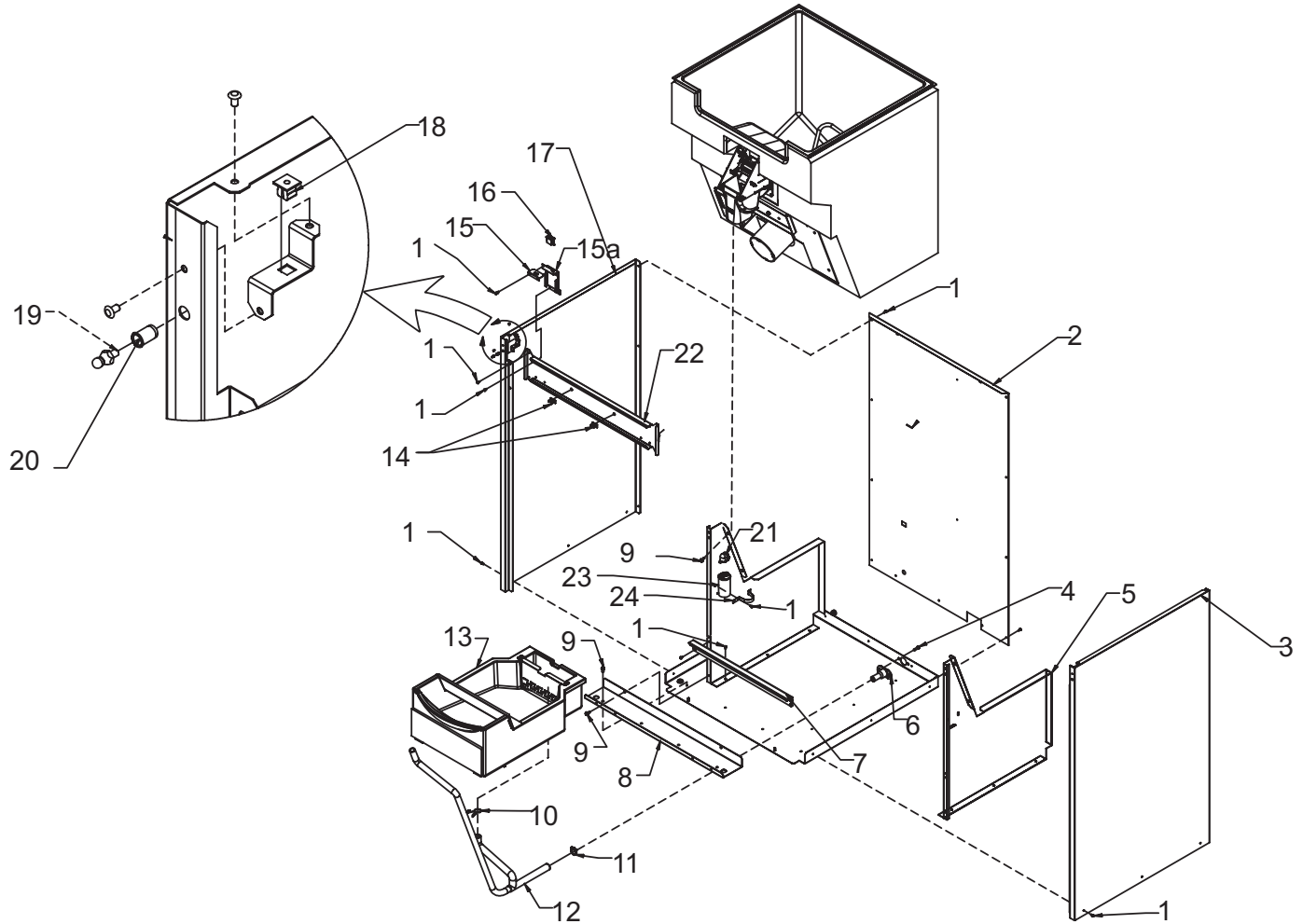

Item Number	Part Number	Description	Item Number	Part Number	Description
1	03-1531-01	Screw	12	02-3979-01	Drain hose
2	A38321-001	HD30 back panel	13	A38316-021	Drain pan, assembled
	A38322-001	HD22 back panel	14	02-3011-01	Wire clamp (coin mech)
3	A38320-022	Right side panel, includes mounting hardware	15	A38435-002	Switch plate top
4	03-0571-01	Screw	15a	A38435-001	Switch plate
5	A38325-002	Bin support, right	16	12-1276-01	Switch, interlock
	A38325-001	Bin support, left	17	A38320-021	Left side panel, includes mounting hardware
6	02-3692-23	Drain fitting	18	03-3804-01	Plastic nut
7	A38348-001	Catch pan support	19	03-1733-01	Strike (ball stud)
8	A38362-001	HD30 base stiffener	20	03-1734-01	Insert
	A38362-002	HD22 base stiffener	21	13-0666-00	Terminal cover
9	03-1645-01	Screw	22	A38333-001	HD30 support bracket
10	02-3791-01	Hose clamp		A38333-002	HD22 support bracket
11	02-2814-09	Hose clamp	23	18-1902-52	Motor capacitor
			24	A35971-001	Strap

HD22 and HD30 Service Parts

Dispensing Components

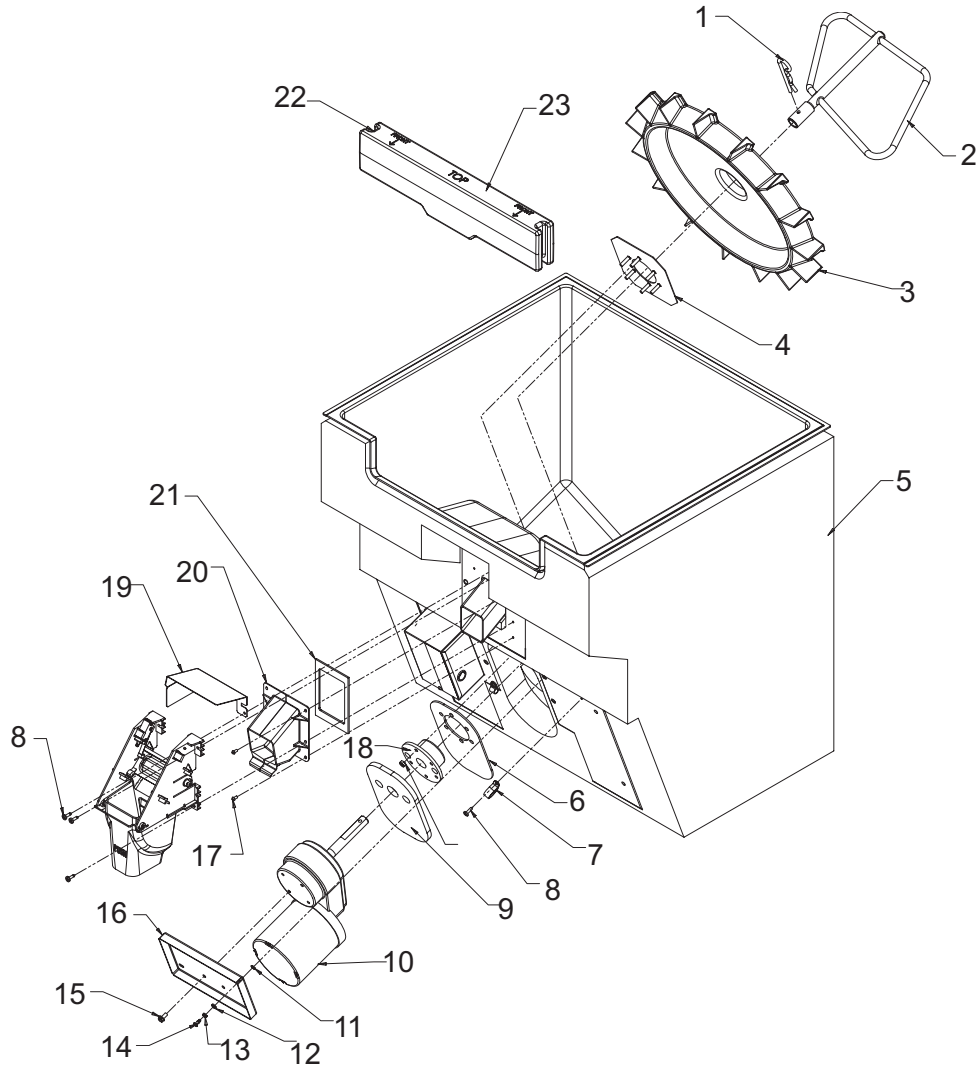

Item Number	Part Number	Description	Item Number	Part Number	Description
1	03-3837-01	Hitch pin	11	03-1731-02	Retainer
2	02-3989-01	Sweep arm	12	03-1731-04	Cupped washer
3	02-3040-01	Dispense rotor	13	03-1731-03	Spring
4	A38145-001	Hub plate	14	03-3838-02	¼ turn stud
5	A38314-001	HD30 bin assembly	15	03-1645-01	Screw
	A38314-002	HD22 bin assembly	16	A38342-001	Mounting plate
6	13-0940-01	Insulation pad	17	03-1531-01	Screw
7	03-3841-02	Loop clamp	18	A34760-001	Hub
8	03-1404-12	Screw	19	A38446-001	Switch guard
9	13-0939-01	Insulation for hub	20	02-3965-01	Spout
10	12-2897-01	Dispense gearmotor, dual voltage	21	02-4000-01	Gasket
			22	19-0503-09	Gasket, 4" each end
			23	A38341-002	Bin door

HD22 and HD30 Service Parts

Ice Chute Mechanism

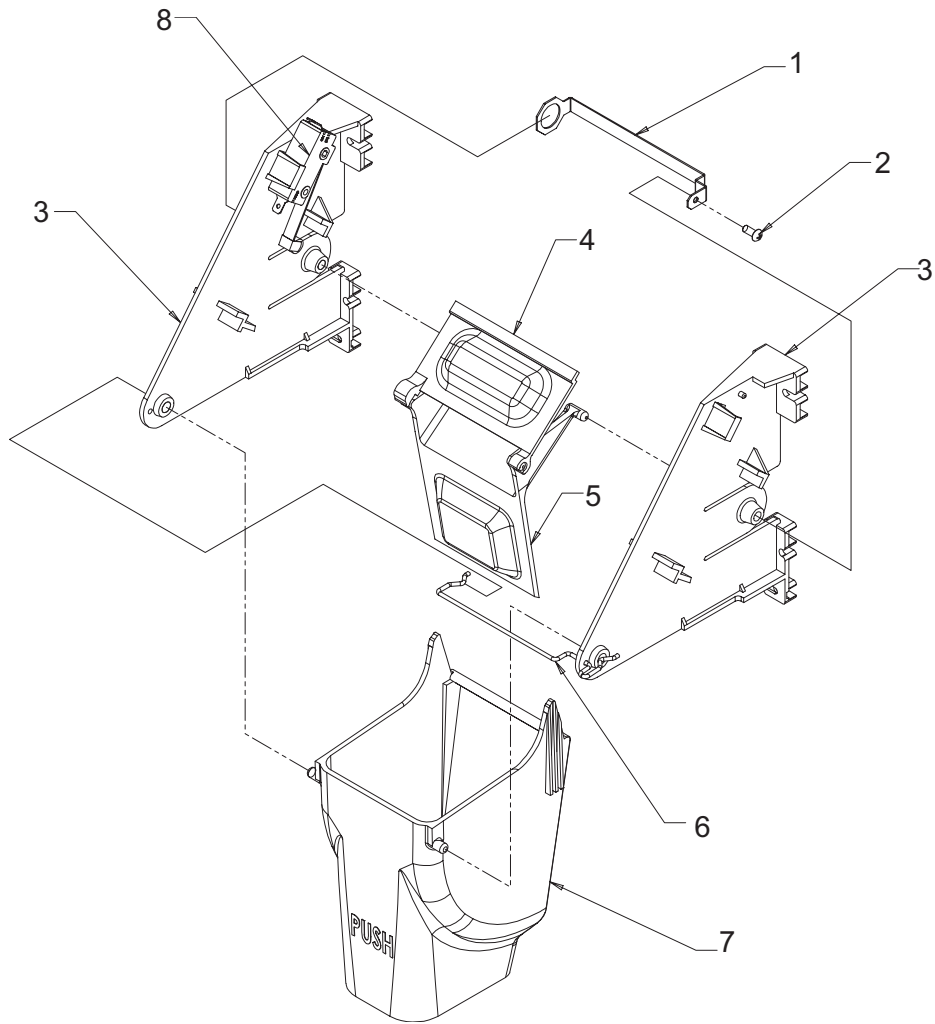

Item Number	Part Number	Description
1	A38455-001	Clip
2	03-1531-01	Screw
3	02-3964-01	Bracket
4	02-3963-01	Door lock
5	02-3962-01	Door
6	02-3970-01	Wire
7	02-3961-01	Dispense chute
8	12-2879-01	Vend switch

HD22 and HD30 Service Parts

Ice Catch Pan

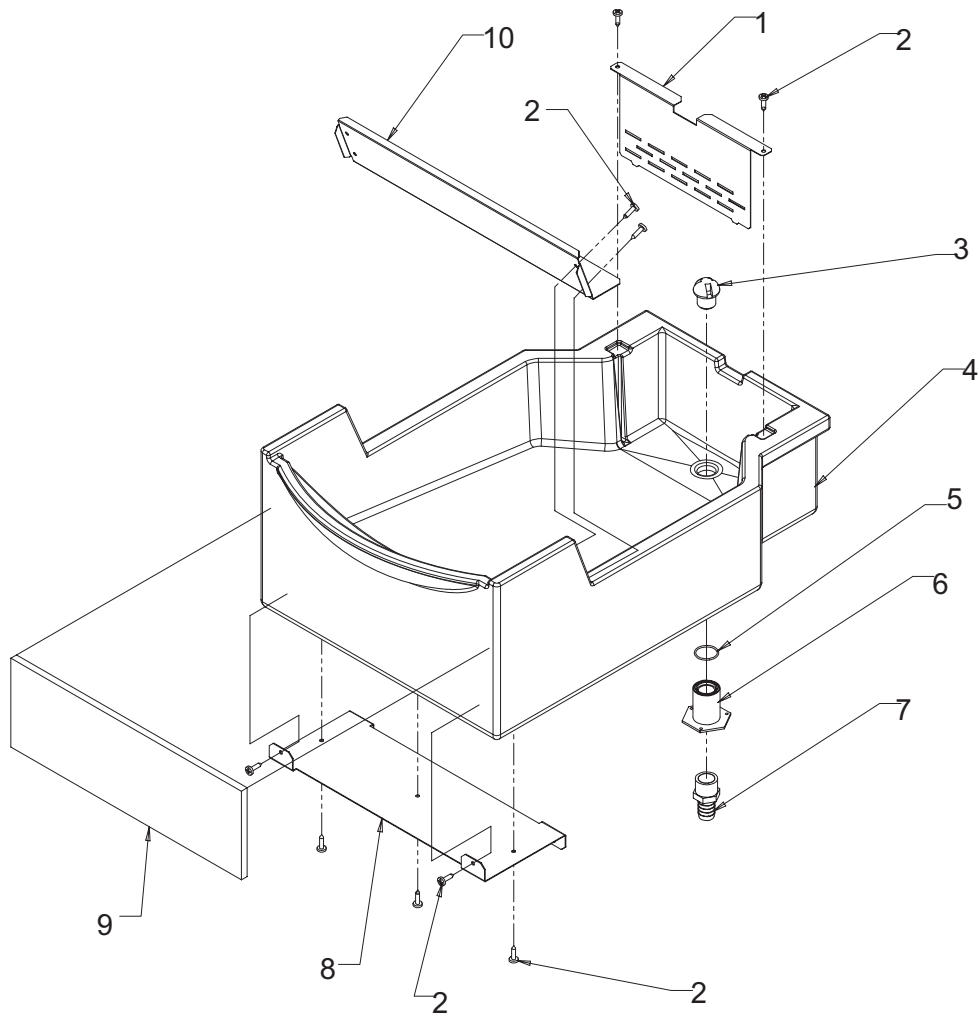

Item Number	Part Number	Description
1	A38332-001	Screen
2	03-1404-12	Screw
3	02-2809-02	Drain top
4	A38316-021	Complete assembly as shown
5	02-4193-01	Flat washer
6	02-3201-01	Drain bottom
7	16-1099-01	Drain fitting
8	A38454-001	Drain pan bracket
9	02-3999-01	Foam pad
10	A38447-001	Drain guard

HD22 and HD30 Service Parts

Control Box

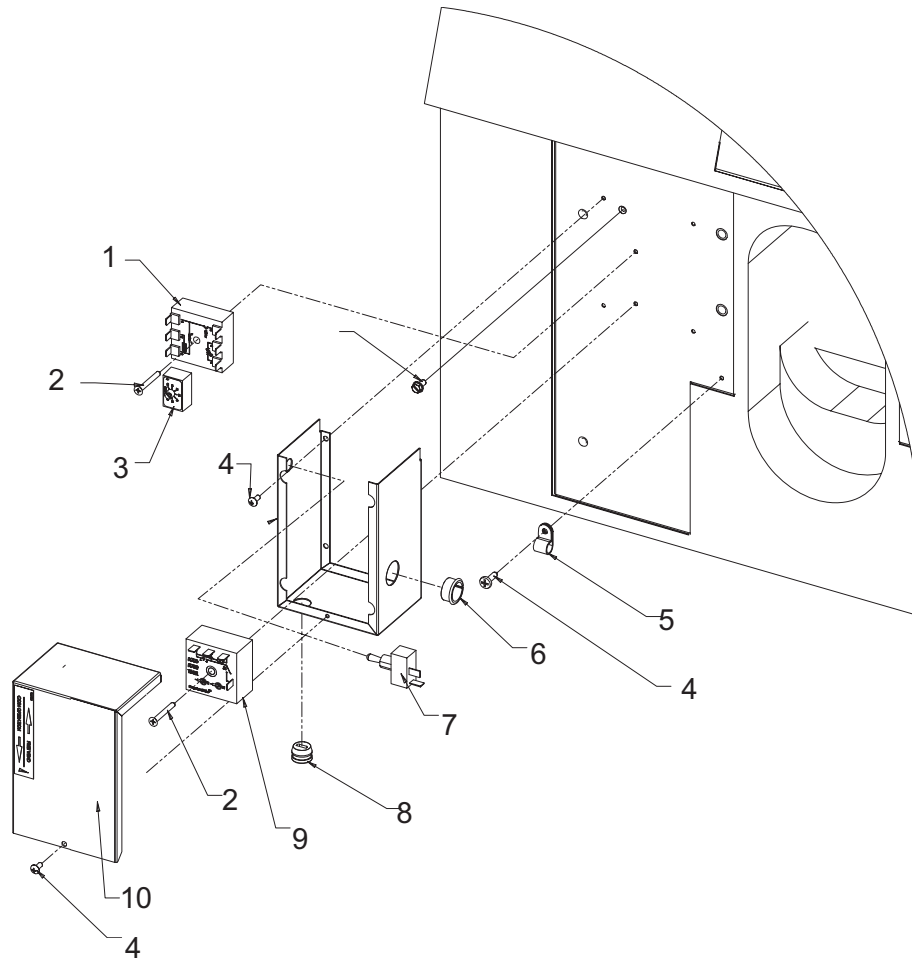

Item Number	Part Number	Description	Not shown		
1	12-2948-01	Coin mech timer*	11	12-2880-01	60 Hz harness, basic and water
2	03-1419-16	Screw		12-2891-01	Coin mech harness
3	part of item 1			12-2904-01	50 Hz harness
4	03-1531-01	Screw	12	12-1638-20	115 volt power cord
5	03-3841-01	Loop clamp		12-1638-18	230 volt power cord
6	12-1213-10	Snap bushing			
7	12-0426-01	Free vend switch			
8	12-0629-08	Strain relief			
9	12-2881-01	60 Hz off cycle timer			
	12-2881-02	50 Hz off cycle timer			
10	A38330-001	Control box cover			

* Note: Use of this timer includes a wiring change. Prior timers had separate adjustment modules and used the wiring diagram on page 13. Refer to page 15 for wiring of this timer.

HD22 and HD30 Service Parts

Wiring Diagram, 115 volt, 60 Hz Basic and Water Station

17-2956-01

ALL CONTROLS SHOWN IN
NORMAL ICE DISPENSING MODE

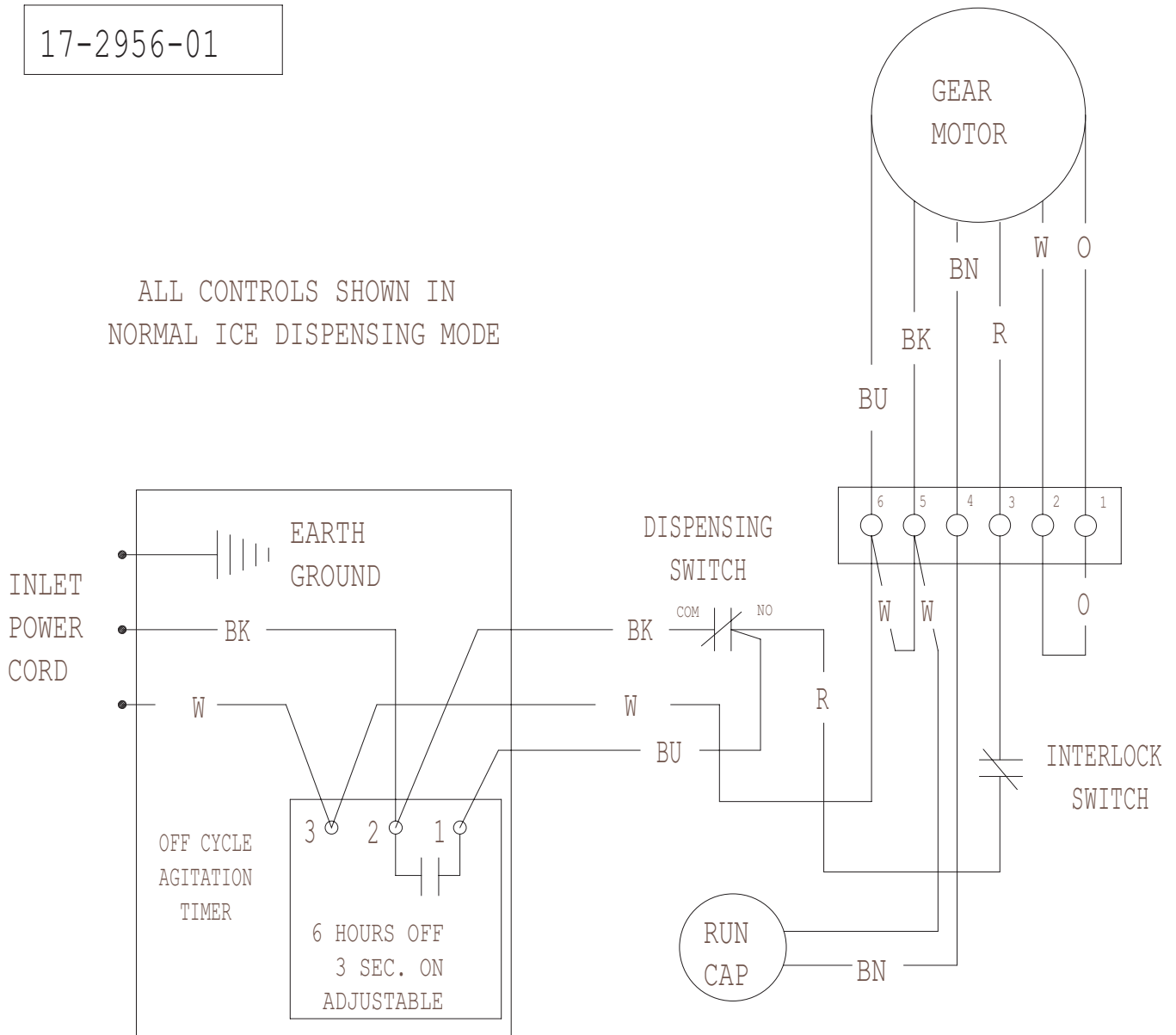

USE COPPER CONDUCTORS ONLY

HD22 and HD30 Service Parts

Schematic Diagram, Basic and Water Station Models

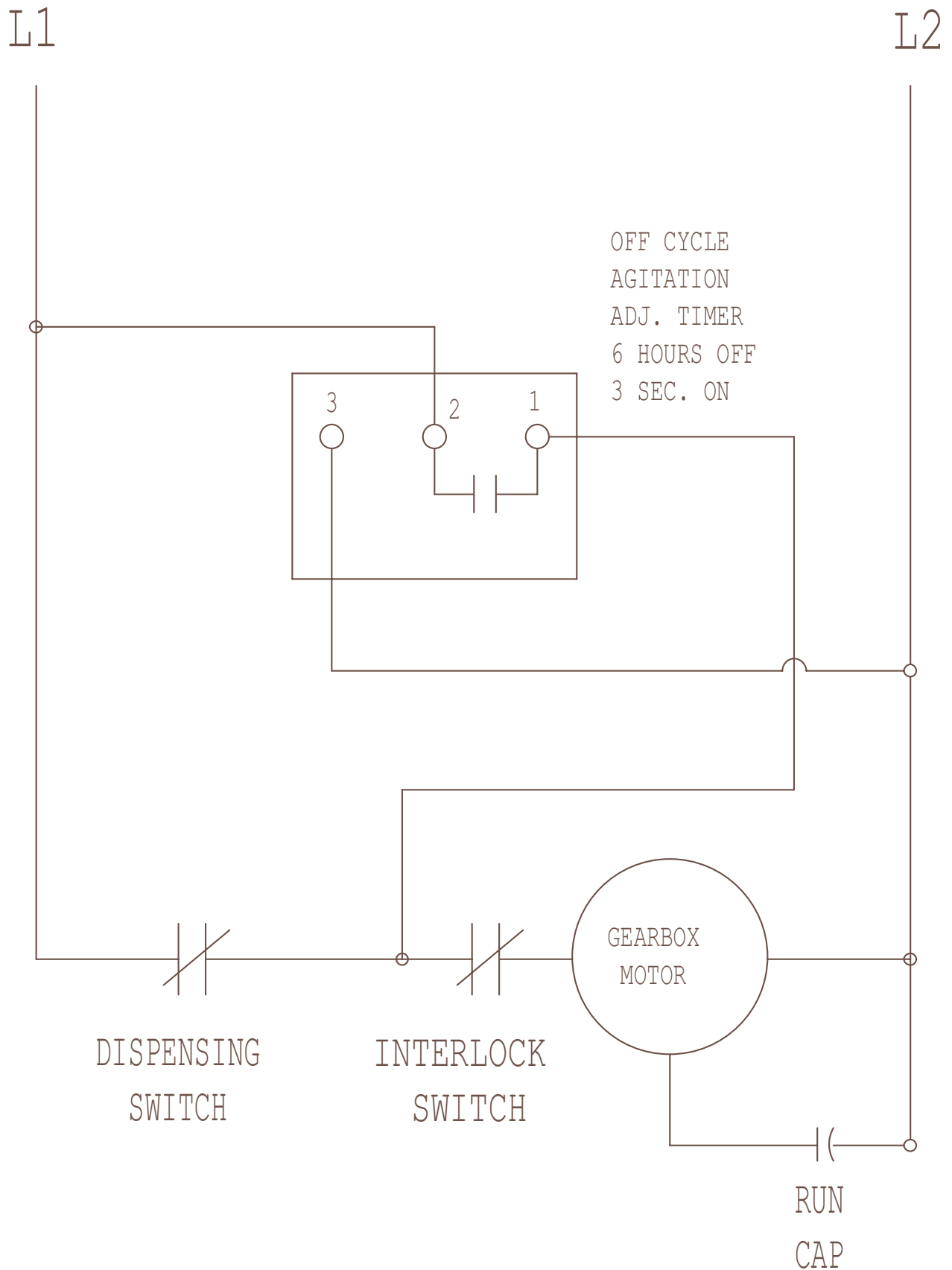

HD22 and HD30 Service Parts

Wiring Diagram, 230 volt, 50 Hz Basic

17-2987-01

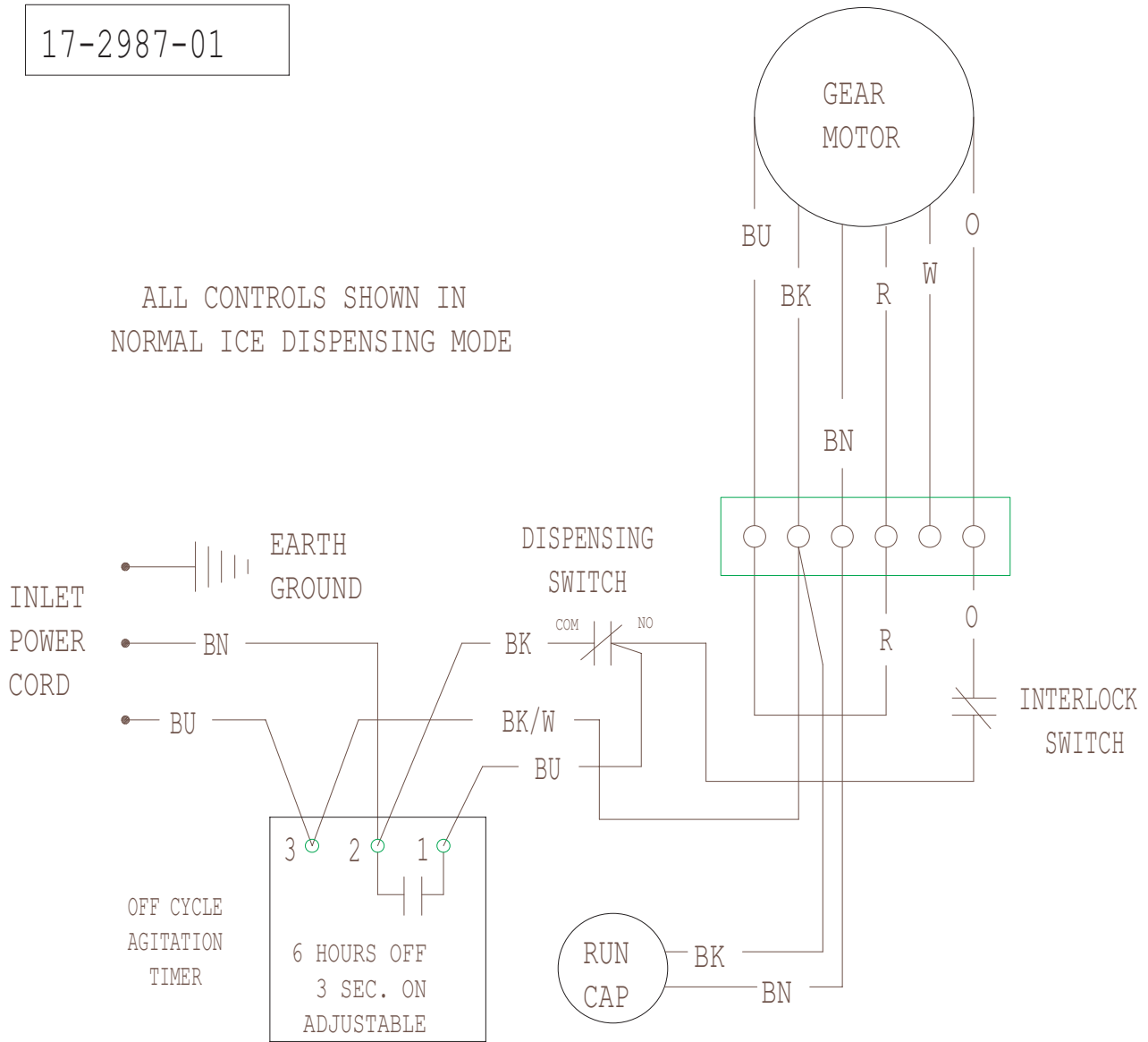

USE COPPER CONDUCTORS ONLY

HD22 and HD30 Service Parts

Wiring Diagram for Coin Mechanism Model, with prior coin mech timer

17-2967-01

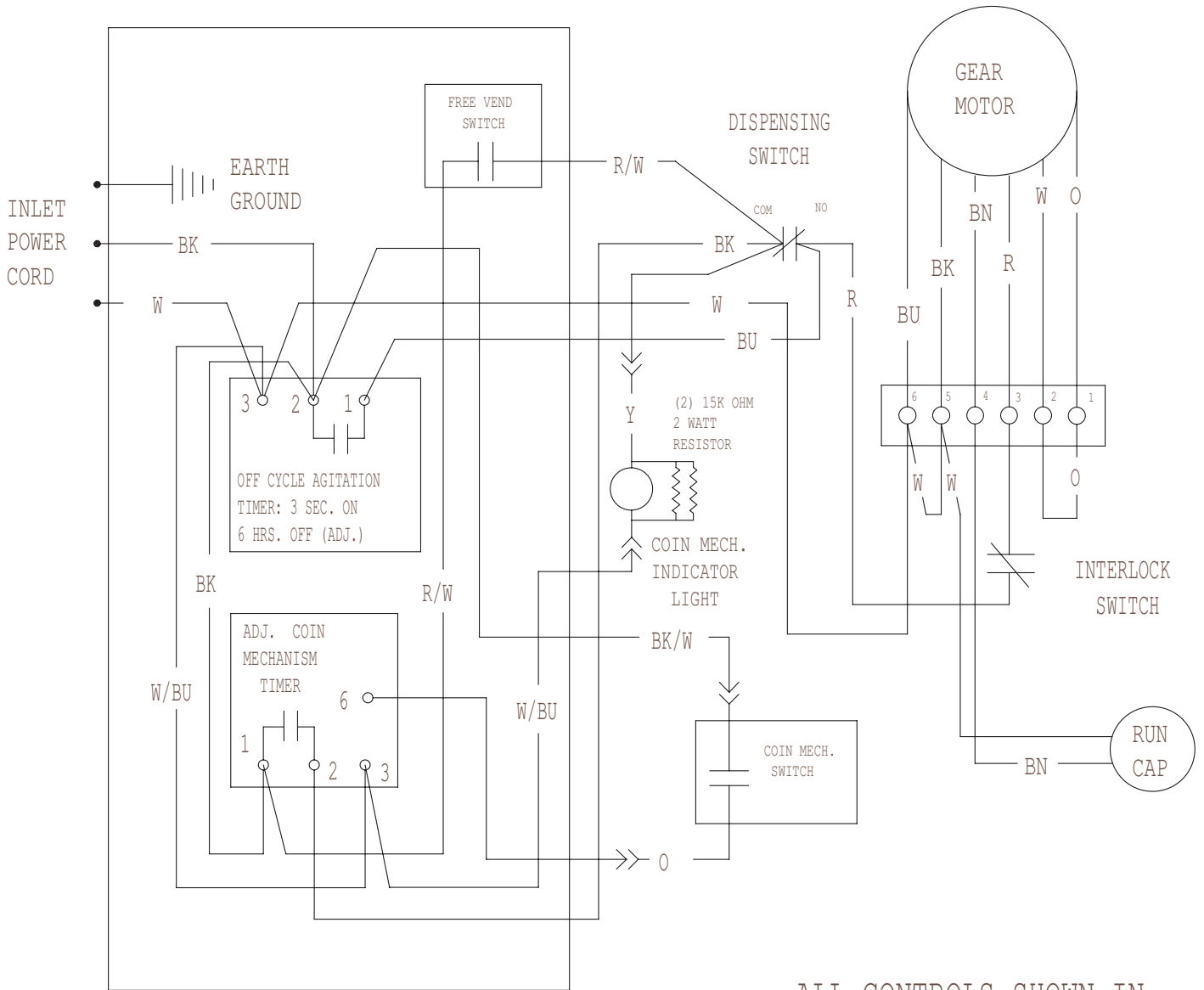

USE COPPER CONDUCTORS ONLY

ALL CONTROLS SHOWN IN
NORMAL ICE DISPENSING MODE

HD22 and HD30 Service Parts

Schematic Diagram for Coin Mechanism Model

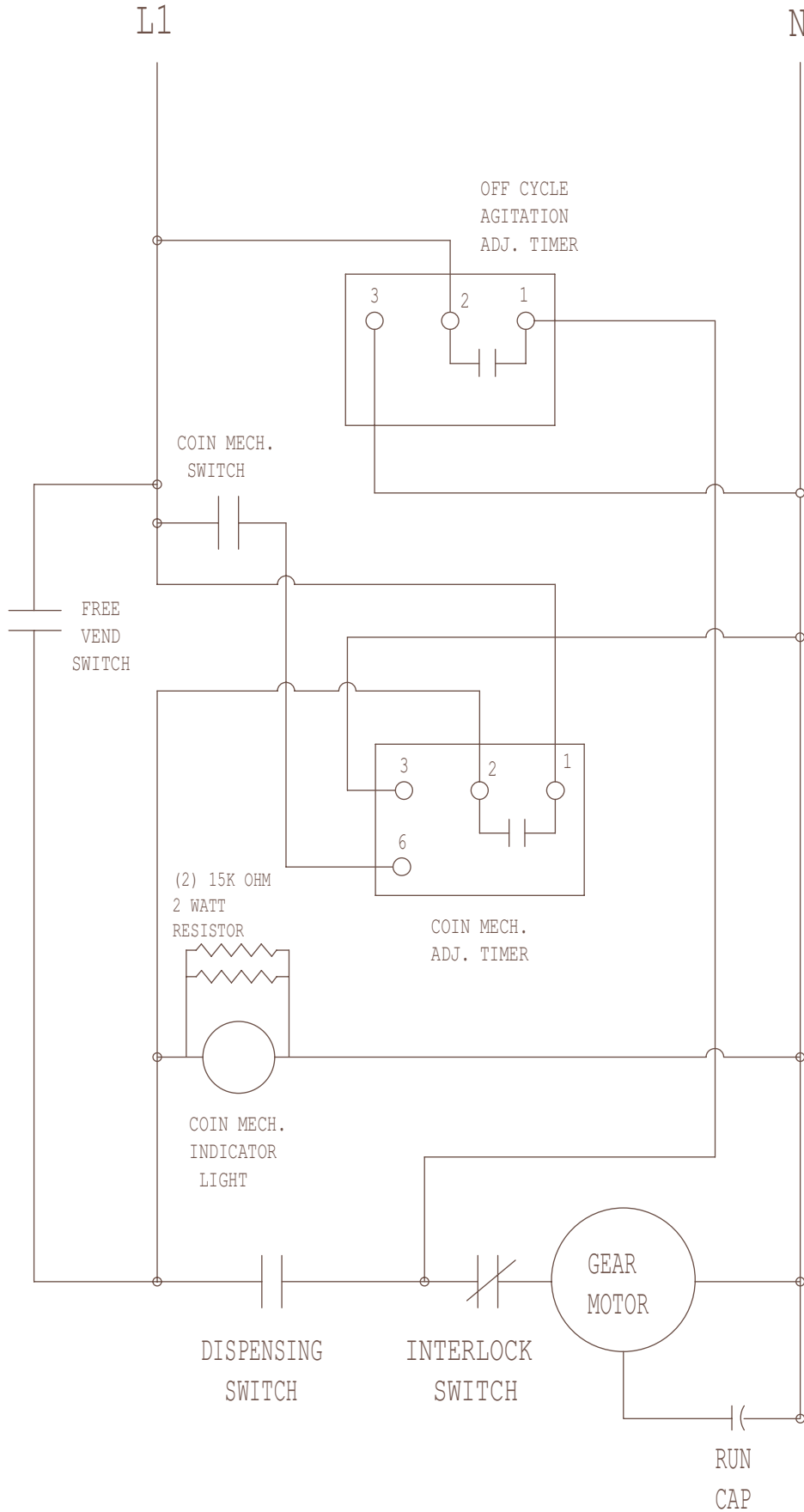

HD22 and HD30 Service Parts

Wiring Diagram for Coin Mechanism Model after 2006 coin mech timer change

