

HOOD TYPE MACHINE

INSULATED DOUBLE WALLED CAPOTE
ELECTROMECHANICAL SWITCHES

TYPE: 373U

Accessories

CAPOTE "LIFT" LIFTING SYSTEM

BREAK TANK

BOOSTER PUMP

DVGW

WATER SOFTNER

DETERGENT DISPENSER

DRAIN PUMP

Spare parts manual

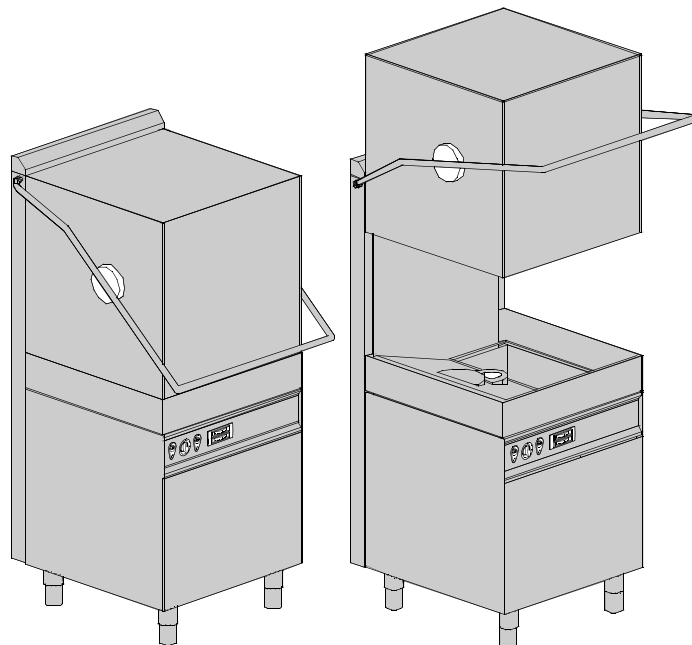

Parti di ricambio Spare Parts Catalogues pièces

INFORMAZIONI GENERALI

Questo catalogo serve per richiedere con esattezza le parti di ricambio

Nelle ordinazioni indicare:

1) il numero dei codici dei particolari seguito dalla descrizione e la quantità desiderata;

2) Il codice alfa-numerico presente nella seconda colonna della tabella ;

I disegni delle parti di ricambio sono solo indicativi e non rappresentano il pezzo in oggetto.

I dati contenuti in questo catalogo sono indicativi e possono essere soggetti a modifiche senza impegno di preavviso.

ALLGEMEINE INFORMATIONEN

Dieser Ersatzteilkatalog dient zur genauen Angabe der Teile bei Ersatzteilbestellungen.

Bei Ersatzbestellung ist folgendes anzugeben:

1) Die Bestellnummer der Ersatzteile mit der entsprechenden Beschreibung genaue Menge;

2) Der alpha-numerischer Code auf der zweiten Reihe in dein Spalte;

Die Zeichnungen der Ersatzteile sind nur als Hinweise gedacht und stellen nicht das betroffene Teil dar.

Bei den im Katalog angeführten Daten handelt es sich um Anhaltsdaten, die jederzeit, ohne Vorankündigung, geändert werden können.

GENERAL INFORMATION

The present spare parts order exactly the right spare parts

When ordering specify:

1) the part's code number followed by its description and quantity needed;

2) The alpha-numeric code is in the second column in the chart;

Spare parts drawings are general and do not represent the part.

The contents of this catalogue are general and can undergo changes without prior notice.

INFORMACIONES GENERALES

El presente catálogo sirve para pedir con exactitud las partes de repuesto

En los pedidos se debe indicar:

1) el número de código de la parte y a continuación la descripción cantidad deseada;

2) El código alfanumérico presente en la signada columna de la tabla;

Los diseños de las partes de recambio son solo indicativos y no representan la pieza en cuestión.

Los datos contenidos en el presente catálogo son indicativos y pueden modificarse sin aviso previo.

INFORMATIONS GENERALES

Ce catalogue permet de commander correctement les pièces détachées

Les commandes doivent être passées en indiquant:

1) le numero de code des pièces dééectachées suivi de leur description quantité désirée;

2) le code alphanumérique dans la deuxième colonne du tableau;

Les plans des pièces détachées sont fournis seulement à titre indicatif et ne représentent pas la pièce concernée.

Les données de ce catalogue sont citées seulement à titre indicatif et peuvent être l'objet de modifications sans avis préalable.

ESEMPIO EXAMPLE EXEMPLE BEISPIEL

Rif.	Codici
MODULE:Particolari	
10505	540903
10510	540908
10515	15065/A
10520	540086
10525	540028



Note

Tutte le informazioni riportate si intendono aggiornate alla data di stampa. Il Produttore si riserva il diritto di apportare qualsiasi modifica richiesta dallo sviluppo evolutivo dei suddetti prodotti.

Per la sicurezza, la garanzia, l'affidabilità ed il valore della lavastoviglie usa solo ricambi originali. **Per alcuni codici, sono richieste quantità minime d'ordine.**



Attenzione

Questo libretto è parte integrante della lavastoviglie e, in caso di passaggio di proprietà, deve essere consegnato al nuovo acquirente.



Remarque

Toutes les informations contenues dans ce manuel s'entendent mises à jour à la date d'impression. En raison du développement constant de ses produits, usine se réserve le droit d'apporter à tout instant les modifications qu'elle jugera utiles.

Pour la sécurité, la garantie, la fiabilité et la valeur de votre lave-vaisselles n'utilisez que des pièces de rechange d'origine. **Pour quelque référence on demande un minimum de pièces par commande**



Attention

Ce manuel doit être considéré comme partie intégrante de la lave-vaisselles, en cas de transfert de propriété, doit toujours être remis au nouveau propriétaire.



Note

The information contained herein is valid at the time of going to print. The Company reserves the right to make any changes required by the future development of the above-mentioned products.

For your safety, as well as to preserve the warranty reliability and worth of your dishwashers, use original spare parts only. **For some codes a minimum quantity for order is required.**



Warning

This manual forms an integral part of the dishwashers and - if a transfer of title occurs - must always be handed over to the new owner.



Hinweis

Die Der Hersteller behält sich das Recht vor, jegliche, durch eine Weiterentwicklung der genannten Produkte bedingte Änderungen vornehmen zu können.

Verwenden Sie für Ihre Sicherheit, die Garantie, die Zuverlässigkeit und den Wert Ihrer machine originale Ersatzteile. **Für bestimmte Code nummer werden mindesten bestellungen verlangt.**



Achtung

Diese Betriebsanleitung ist Bestandteil des machine und muss bei seinem Weiterverkauf dem neuen Besitzer ausgehändigt werden.

1. Spare parts

General body parts.....	7
Closing panelig.....	9
Hood LIFT lifting system	11
Control panel and switches.....	13
Electric control components.....	15
Solenoid valve group	17
Solenoid valve group	19
Break Tank	21
Rinse with steady temperature.....	23
Booster pump.....	25
DVGW	27
Water softner group.....	29
Rinse aid dispenser group.....	31
Boiler group	33
3 ways connection	35
Wash pump group.....	37

Dosing detergent group.....	39
Dosing detergent group.....	41
Drain pump group.....	43
Pressure switch group with air trap ...	45
Turret group with rotating arms	47

1.1 Voltage codes

Voltage code	Voltage
A	3/N/PE~400/230V 50Hz
B	~250V 16A 50Hz
C	3/N/PE~380/220V 50Hz
D	3/PE~200V 50-60Hz
F	2/PE 220-240V 50Hz
G	3/N/PE~415/240V 50Hz
H	3/PE~230V 50Hz
I	3/PE~220V 60Hz
J	3/PE~380 50Hz
K	3/PE~400V 50Hz
L	3/PE~415V 50Hz
M	3/PE~440V 60Hz
N	3/PE~460V 60Hz
O	3/PE~480V 60Hz
P	1/N/PE~220-240V 50Hz
R	2/PE~220-230V 60Hz
S	3/N/PE~400/230V 50Hz
T	3/PE~230V 60Hz

1.2 Product codes

Product code	Full name
Model codes	
is	INSULATED DOUBLE WALLED CAPOTE
em	ELECTROMECHANICAL SWITCHES
Type codes	
373U	373U
Accessory codes	
lift	CAPOTE "LIFT" LIFTING SYSTEM
bt	BREAK TANK
pap	BOOSTER PUMP
dvgw	DVGW
d	WATER SOFTNER
dde	DETERGENT DISPENSER
ps	DRAIN PUMP

01_028_e

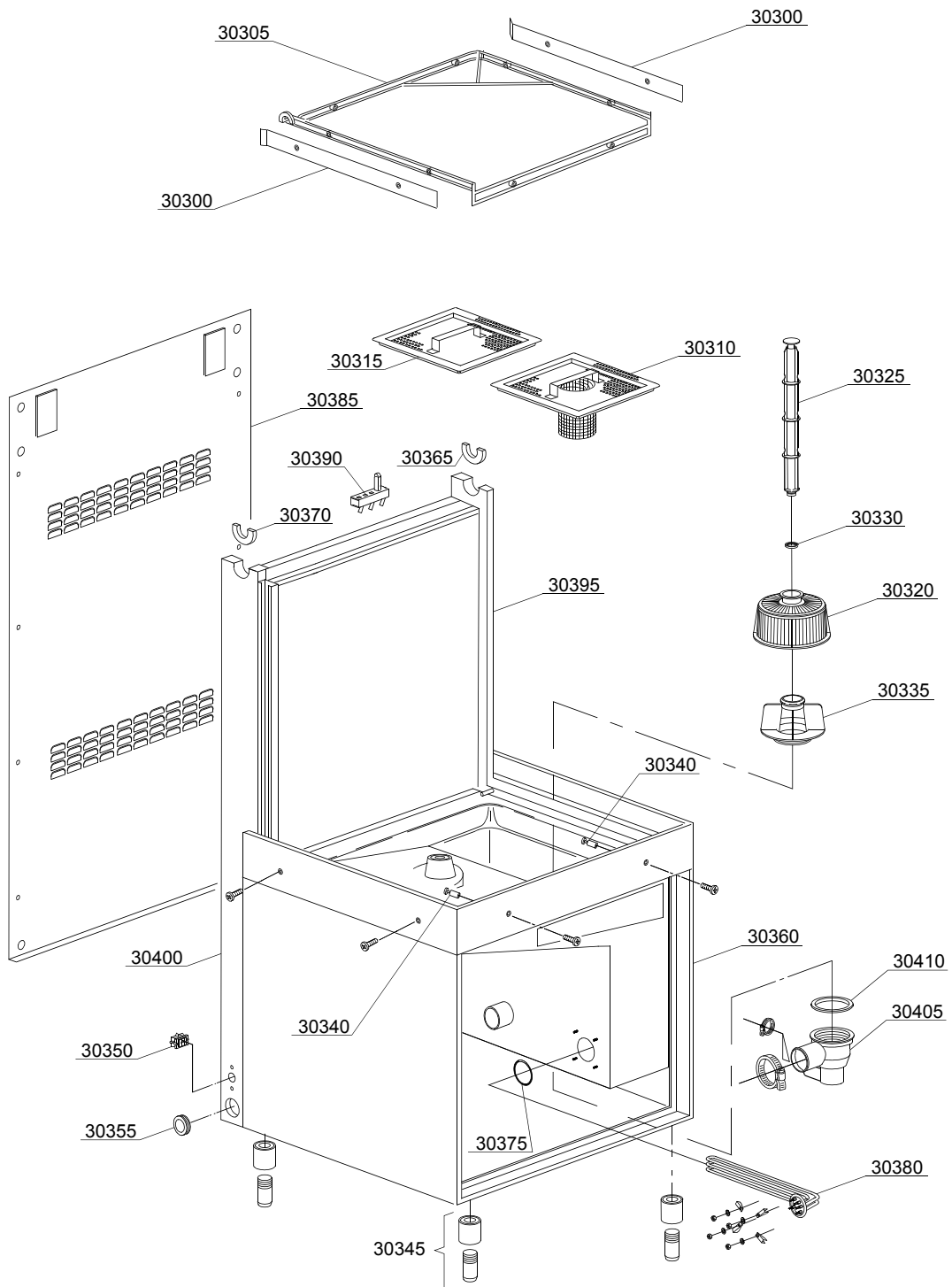

Spare parts

ID	Code	Model	Type	Accessory	Voltage	Description
MODULE:General body parts						
30300	10600923		373U			Basket side
30305	11600001		373U			Basket support
30310	11600906		373U			Strainer with hole
30315	11600907		373U			Strainer
30320	500616		373U			Suction filter
30325	11600102		373U			Overflow pipe
30330	13021		373U			DEM 40 O-ring
30335	500615		373U			Ferrule with filter
30340	11600018		373U			Basket support holder pin
30345	15116		373U			Foot
30350	15065/A		373U			Cable-fastener with screw
30355	13324		373U			Ø46 mm lead through rubber
30360	11600960		373U			Frame assembly
30365	11600016		373U	lift		Right slide bearing
30365	11600055		373U			Right/left slide bearing
30370	11600017		373U	lift		Left slide bearing
30370	11600055		373U			Right/left slide bearing
30375	13015		373U			6225 OR 160 NBR O-ring
30380	15047/A		373U			2,7/2,94KW 230/240V 3 heating element
30385	11600630		373U			Back panel
30390	70305		373U			Hood switch
30395	11600620		373U			Right guide rail support
30400	11600621		373U			Left guide rail support
30405	500605		373U			Outlet connection
30410	80208		373U			95x75x3 O-ring

02_202_e

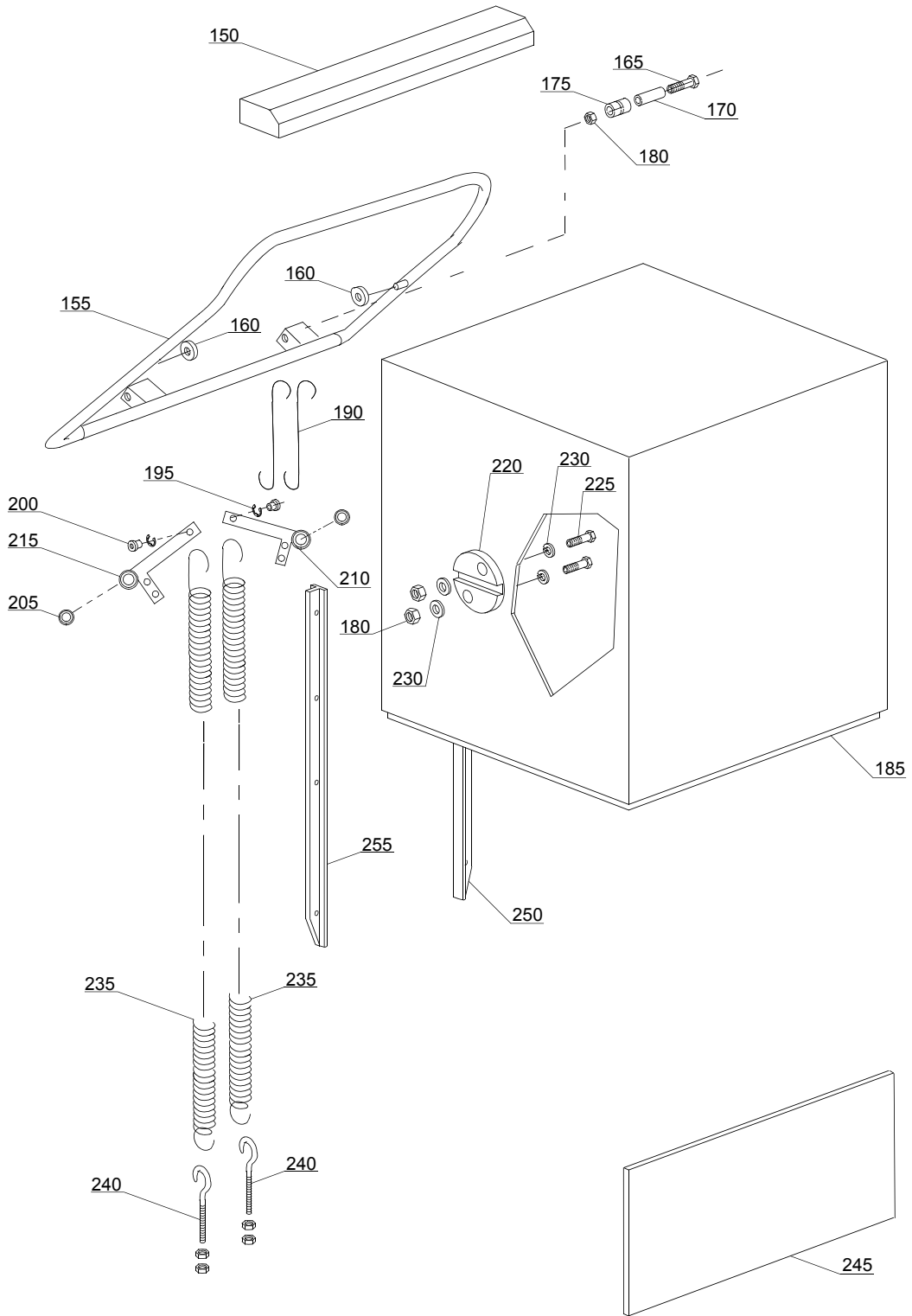

ID	Code	Model	Type	Accessory	Voltage	Description
MODULE:Closing panelig						
150	11600913		373U			Cover
155	11600910		373U			Handle
160	89919		373U			Hood roller
165	11214		373U			Screw
170	11600015		373U			Roller spacer
175	11600014		373U			Roller tie rod
180	11718		373U			M8 stainless steel self-locking nut
185	11600902		373U			Hood
190	11600013		373U			Movement mediating bar
195	11823		373U			Ø10 stainless steel snap ring
200	11600038		373U			Spring bush
205	10800010		373U			Lever bearing
210	11600026		373U			Right lever
215	11600027		373U			Left lever
220	11600030		373U			Hood movement cam
225	11110		373U			M8x35 TE stainless steel screw
230	13301		373U			O-ring
235	70302		373U			Hood spring
240	10800210		373U			Spring hook
245	11600953		373U			Lower front panel
250	11600028		373U			Hood right sliding guide
255	11600029		373U			Hood left sliding guide

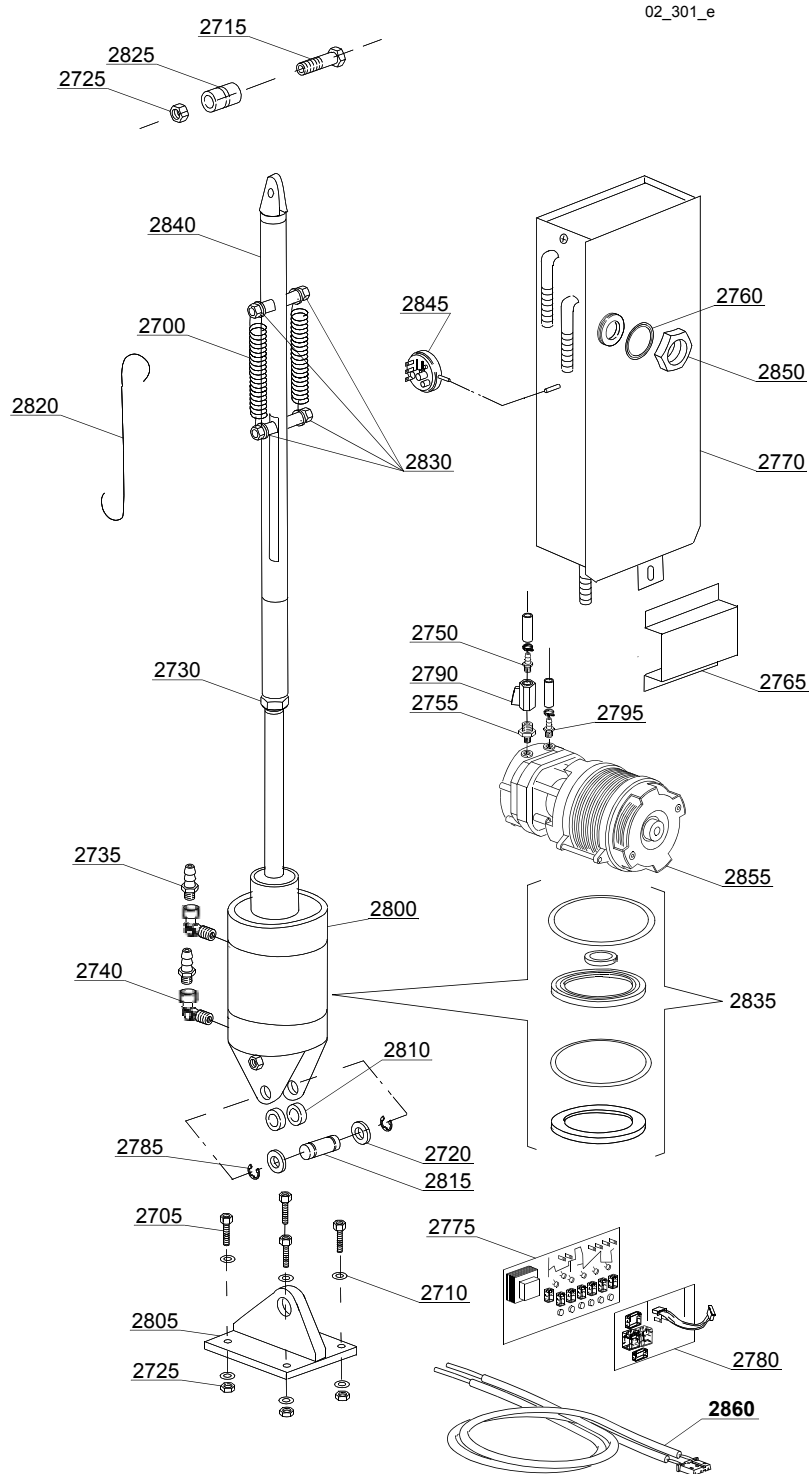

ID	Code	Model	Type	Accessory	Voltage	Description
MODULE:Hood LIFT lifting system						
2700	10700		373U	lift		Spring
2705	11166		373U	lift		Screw
2710	11177		373U	lift		Plain washer
2715	11215		373U	lift		Screw
2720	11617		373U	lift		Washer
2725	11718		373U	lift		M8 stainless steel self-locking nut
2730	11720		373U	lift		M16 stainless steel nut
2735	12005		373U	lift		Rubber-holder
2740	12012		373U	lift		M/F 1/4 Elbow
2750	12013		373U	lift		Hose coupling - 10mm - 3/8"
2755	12034		373U	lift		Reduction nipple 3/8" - 1/2"
2760	13305		373U	lift		44x32x3 O-ring
2765	15738		373U	lift		Overflow cover
2770	15745		373U	lift		Water receiver
2775	50569		373U	lift		Electronic Card without Chip
2775	50557		373U	lift		60/100/180 Eco-2 electronic print card
2780	50559		373U	lift		Relay card
2785	3002069		373U	lift		Stainless steel snap ring
2790	3002140		373U	lift		FF 1/2 tap
2795	10221311		373U	lift		Hose coupling - 12mm - 3/8"
2800	11600042		373U	lift		Hydraulic piston
2805	11600043		373U	lift		Flange for piston
2810	11600044		373U	lift		Spacer for flange joint
2815	11600045		373U	lift		Piston axel pin for flange
2820	11600046		373U	lift		Piston movement bar
2825	11600047		373U	lift		Strengthened bushing
2830	11600049		373U	lift		Pins spring attachment
2835	11600053		373U	lift		Gasket kit hydraulic piston
2840	11600917		373U	lift		Piston lifting arm
2845	10706/A		373U	lift		47-27 pressure switch
2850	11701/A		373U	lift		Stainless steel nut
2855	15100/D		373U	lift		Booster pump 220-240/50
2860	50562		373U	lift		Temperature probe set

Spare parts

ID	Code	Model	Type	Accessory	Voltage	Description
MODULE:Control panel and switches						
30500	11600950		373U			Control panel
30505	89341		373U			Start push button
30505	89348		373U			Blind push button
30505	89345		373U			Regeneration push button
30505	89343		373U			Drain pump push button
30510	89340		373U			ON-OFF push button
30515	10300208		373U			Rotating selector switch
30520	89349		373U			Selector switch support
30525	89321		373U			Selector switch handle control
30530	89323		373U			Screw retainer
30535	89322		373U			Selector switch screw retainer support
30545	89300		373U			Push button support
30545	89332		373U			OR O-ring
30550	15826		373U			Pilot light
30555	15812		373U			16A switch
30565	15813		373U			16A unipolar switch
30565	15844		373U			Push button support
30565	15800		373U			16A bipolar switch
30570	10500011		373U			Thermometer
30575	89306		373U			Double thermometer support
30580	89331		373U			OR O-ring
30585	10711/B		373U			Pilot light

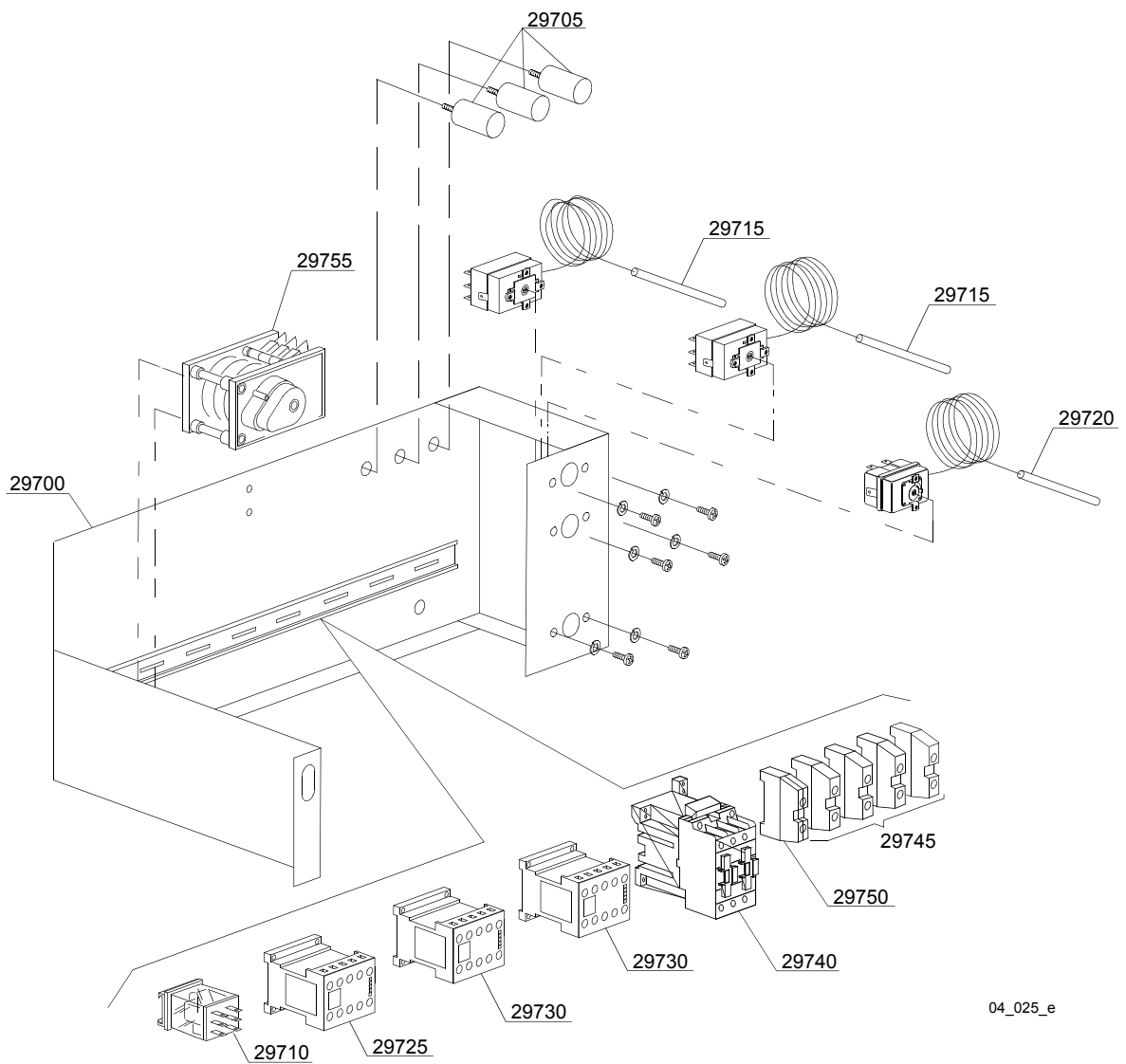
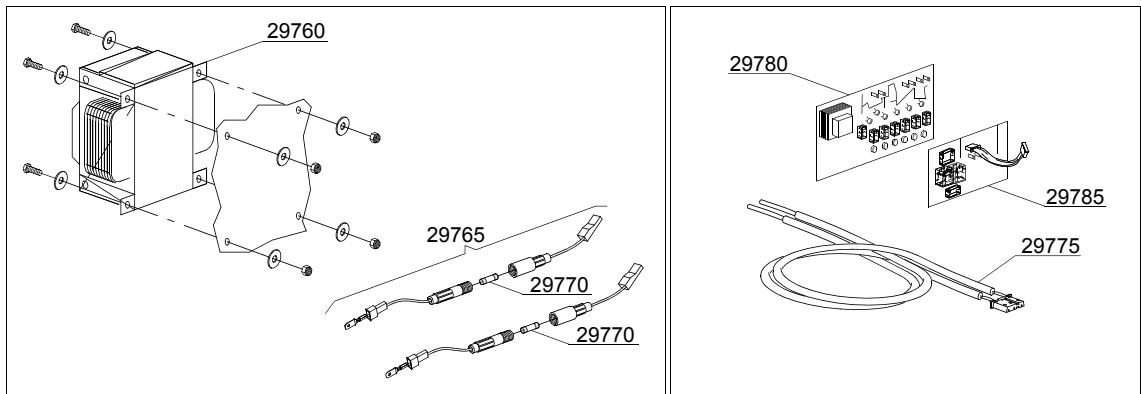

04_025_e

Spare parts

ID	Code	Model	Type	Accessory	Voltage	Description
MODULE:Electric control components						
29700	11600955		373U			Electric component panel
29705	15149		373U			Low noise filter
29710	560301		373U	lift		Relay
29715	10707/1		373U			0-90°C thermostat
29720	2000430		373U			Safety thermostat
29725	10300391		373U			3NA/1NC contactor - 230V 50/60HZ
29725	10300392		373U			3NA/1NC contactor - 240Vac 50Hz
29730	15086		373U			Contactor 230V 50/60Hz 4C
29730	15086/B		373U			Contactor 240V 50Hz
29740	10300050		373U			25A/12A contactor - 230V 50/60HZ
29740	10300052		373U			36A/20A contactor - 230V 50/60HZ
29740	10300054		373U			25A/16A contactor - 230V 50/60HZ
29745	10300401		373U			6/8mm ² yellow/green terminal
29750	10300403		373U			6mm ² terminal
29755	10300122		373U			"50/100/150"" timer"
29760	15381		373U			160Va transformer
29765	15147		373U			Fuse-holder
29770	15163		373U			Fuse
29775	50562		373U	ws		Temperature probe set
29780	50569		373U			Electronic card without chip
29780	50557		373U	ws		60/100/180 Eco-2 electronic print card
29785	50559		373U	dp,ws		Relay card

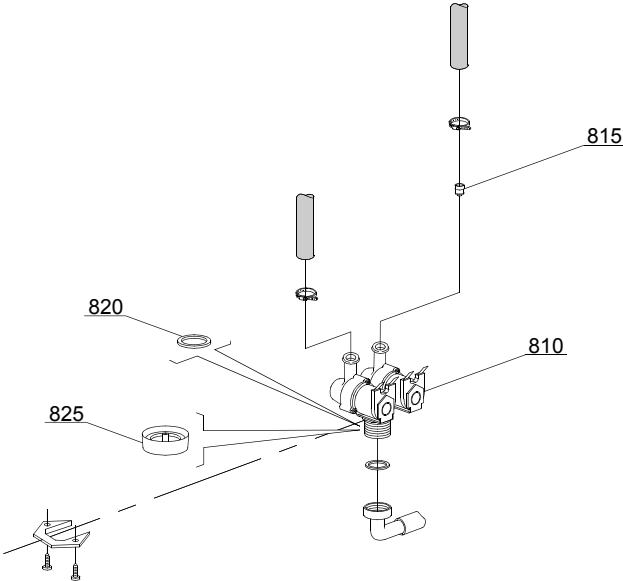

05_003_e

Spare parts

ID	Code	Model	Type	Accessory	Voltage	Description
MODULE: Solenoid valve group						
810	15098		373U	cr,ws		Double solenoid valve - Ø10
810	30001001		373U	lift		Double solenoid valve - Ø12
820	N.C.		373U	cr,ws		Pression reducing valve

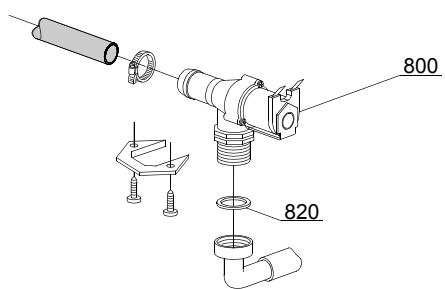

05_005_e

Spare parts

ID	Code	Model	Type	Accessory	Voltage	Description
MODULE: Solenoid valve group						
800	30001000		373U			Single solenoid valve
820	N.C.		373U			Pression reducing valve

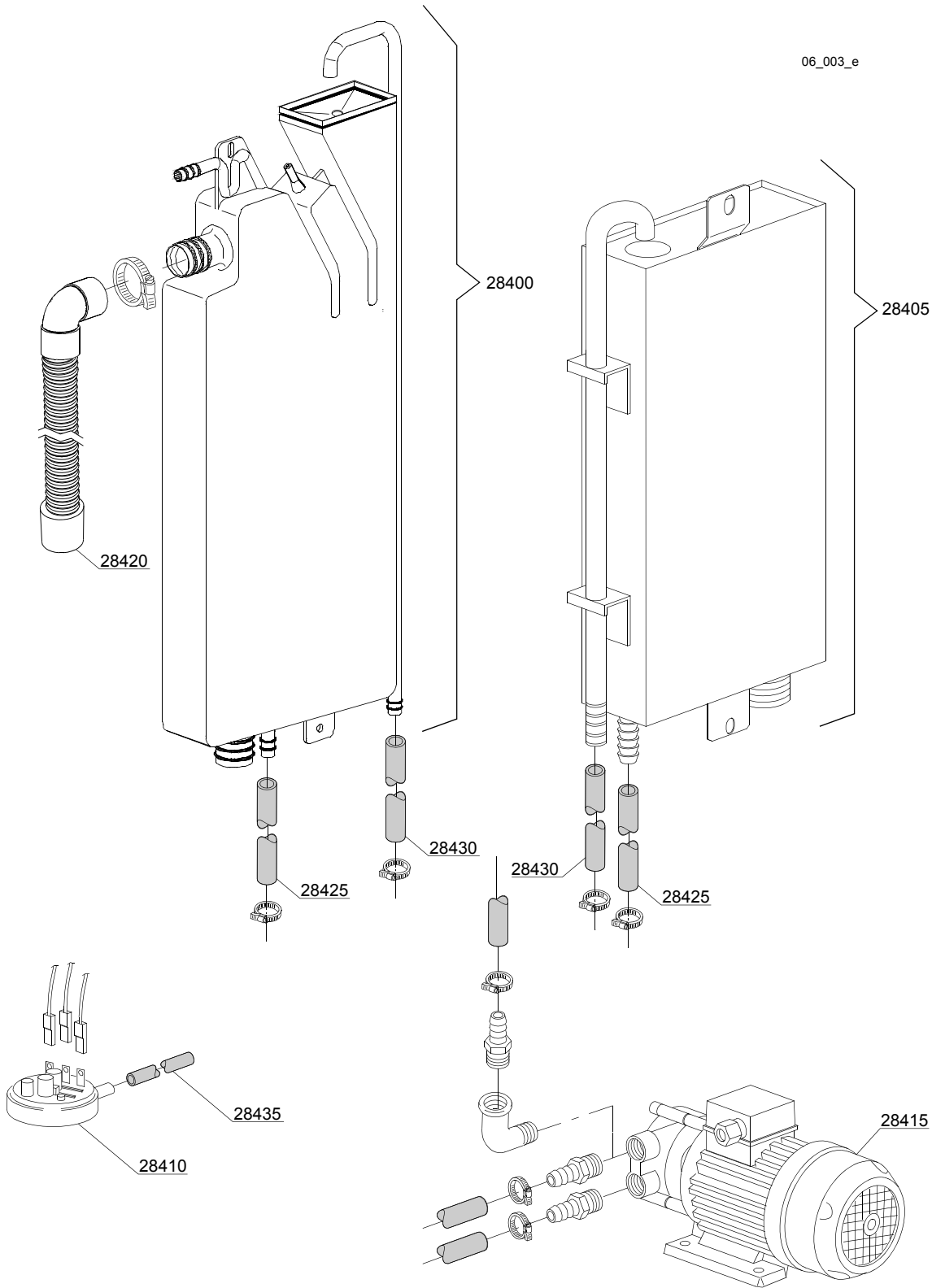

Spare parts

ID	Code	Model	Type	Accessory	Voltage	Description
MODULE:Break Tank						
28400	15720		373U	bt		Break tank assembly
28405	15735		373U	bt		Break tank assembly
28410	10706/A		373U	bt		47-27 pressure switch
28415	15100/D		373U	bt		Booster pump 0,5HP 220/240V
28420	15721		373U	bt		BT long pipe L=1070
28420	15722		373U	bt		BT middle pipe L=920
28420	15723		373U	bt		BT small pipe L=920
28425	2907350		373U	bt		12x20 EPDM rubber hose
28430	2907352		373U	bt		PVC WRAS rubber hose
28435	14508		373U	bt		4,5x9 EPDM rubber hose

06_005_e

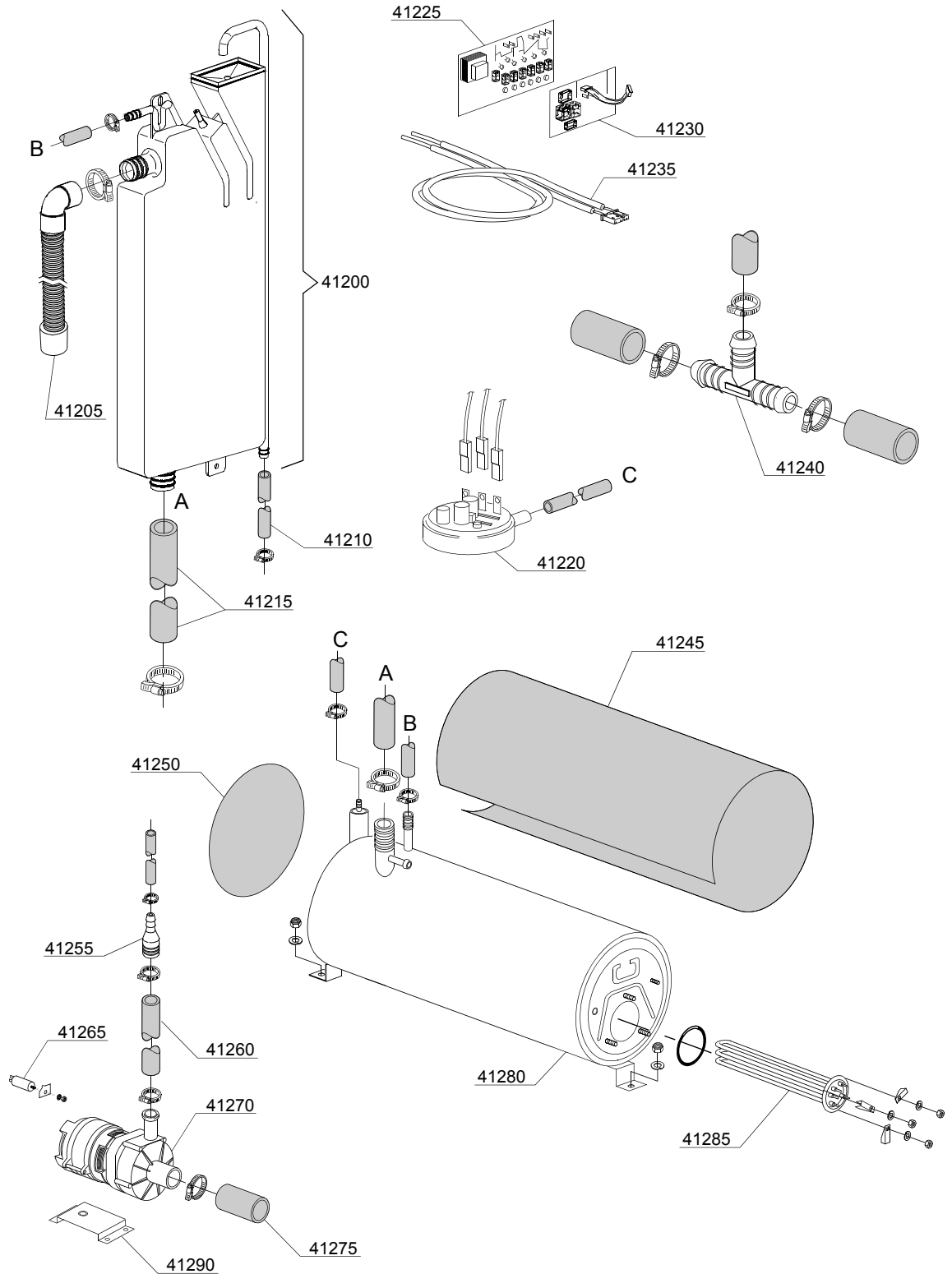

Spare parts

ID	Code	Model	Type	Accessory	Voltage	Description
MODULE:Rinse with steady temperature						
41200	15720		373U			Break tank assembly
41205	15721		373U			BT middle pipe L=920
41210	2907352		373U			PVC WRAS rubber hose
41215	x		373U			Pipe coupling
41220	10706/A		373U			34-100 pressure switch
41225	50569		373U			Electronic Card without Chip
41230	50559		373U			Relay card
41235	50562		373U			Temperature probe set
41240	540098		373U			3 ways D25
41245	30002030		373U			Insulation boiler
41250	75205		373U			Ø160 end piece
41255	3003063		373U			Reducer
41260	10718		373U			Pump pipe coupling
41265	10702		373U			5 uF condenser
41270	10508		373U			Rinsing pump
41275	10718		373U			Pump pipe coupling
41280	11600104		373U			Boiler
41285	30001011		373U			9 kW heating element
41290	440122		373U			Pump support

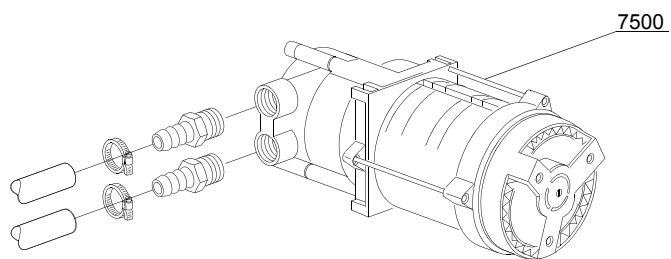

07_003_e

Spare parts

ID	Code	Model	Type	Accessory	Voltage	Description
MODULE:Booster pump						
7500	15100/D		373U	bp		Booster pump 220-240/50

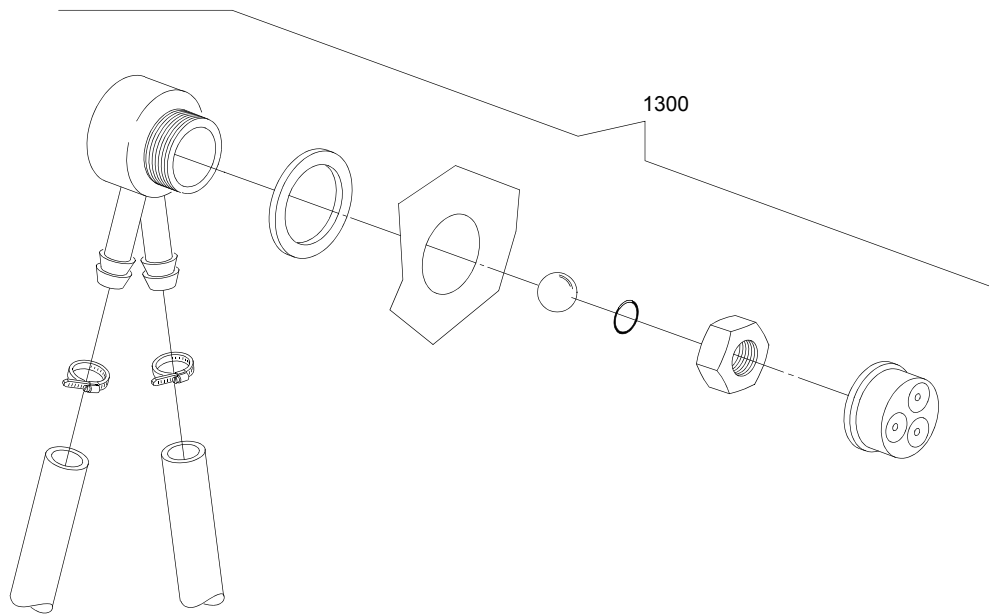

08_005_e

Spare parts

ID	Code	Model	Type	Accessory	Voltage	Description
MODULE:DVGW						
1300	999900006		373U	dvgw		DVGW assembly

09_001_e

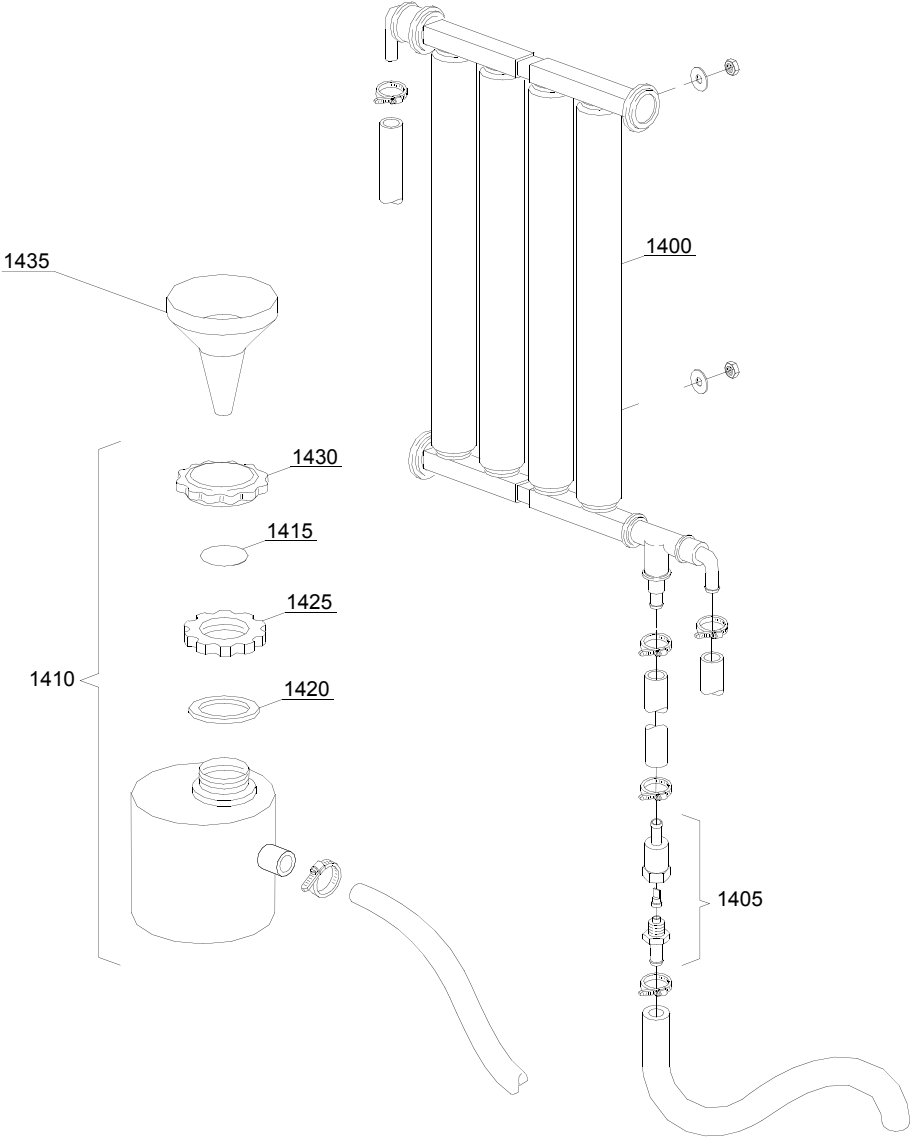

Spare parts

ID	Code	Model	Type	Accessory	Voltage	Description
MODULE:Water softner group						
1400	16066		373U	ws		4 elements water softner
1405	16070		373U	ws		Nonreturn valve
1410	16065		373U	ws		Salt container
1415	16067/A		373U	ws		OR O-ring
1420	16067/B		373U	ws		O-ring
1425	16067/C		373U	ws		Ring nut
1430	16067/D		373U	ws		Plug
1435	16082		373U	ws		Funnel

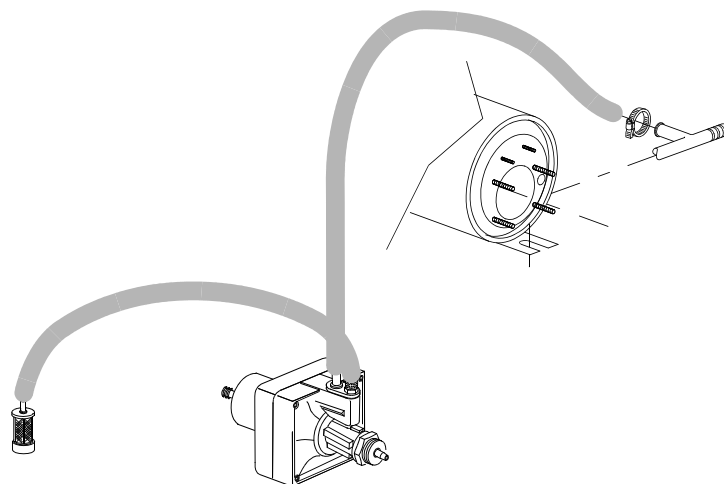
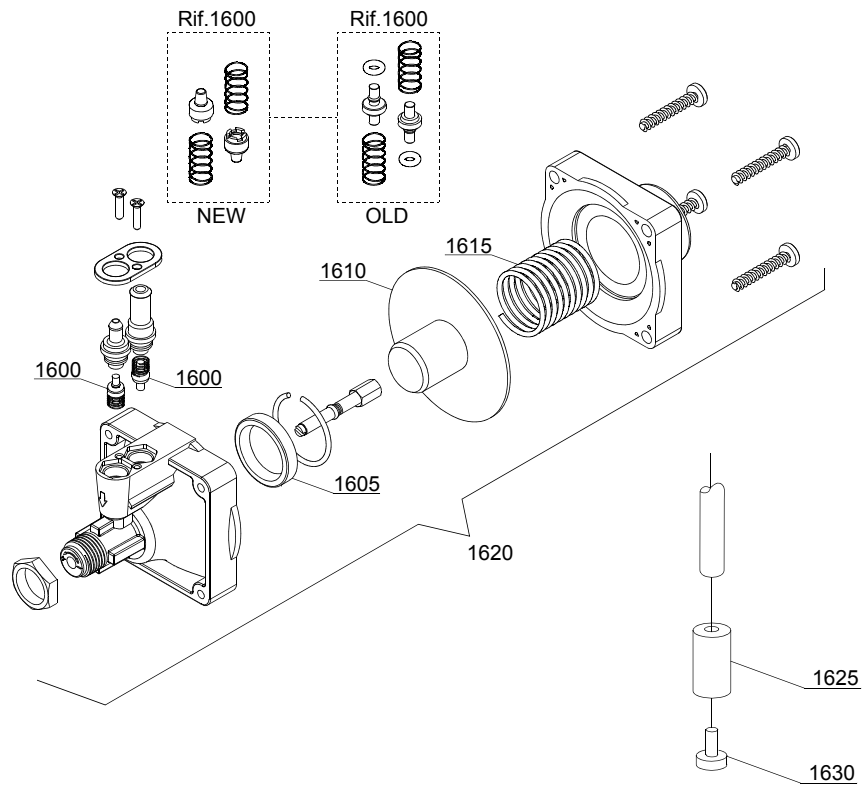

10_003_e

ID	Code	Model	Type	Accessory	Voltage	Description
MODULE: Rinse aid dispenser group						
1600	10805		373U			Tecnopro non return valve
1605	10806		373U			Ø22 O-ring
1610	10807		373U			Membrane
1615	10808		373U			Spring
1620	10599999		373U			Rinse aid dispenser
1625	12525		373U			Counter-weight
1630	15058		373U			Small filter

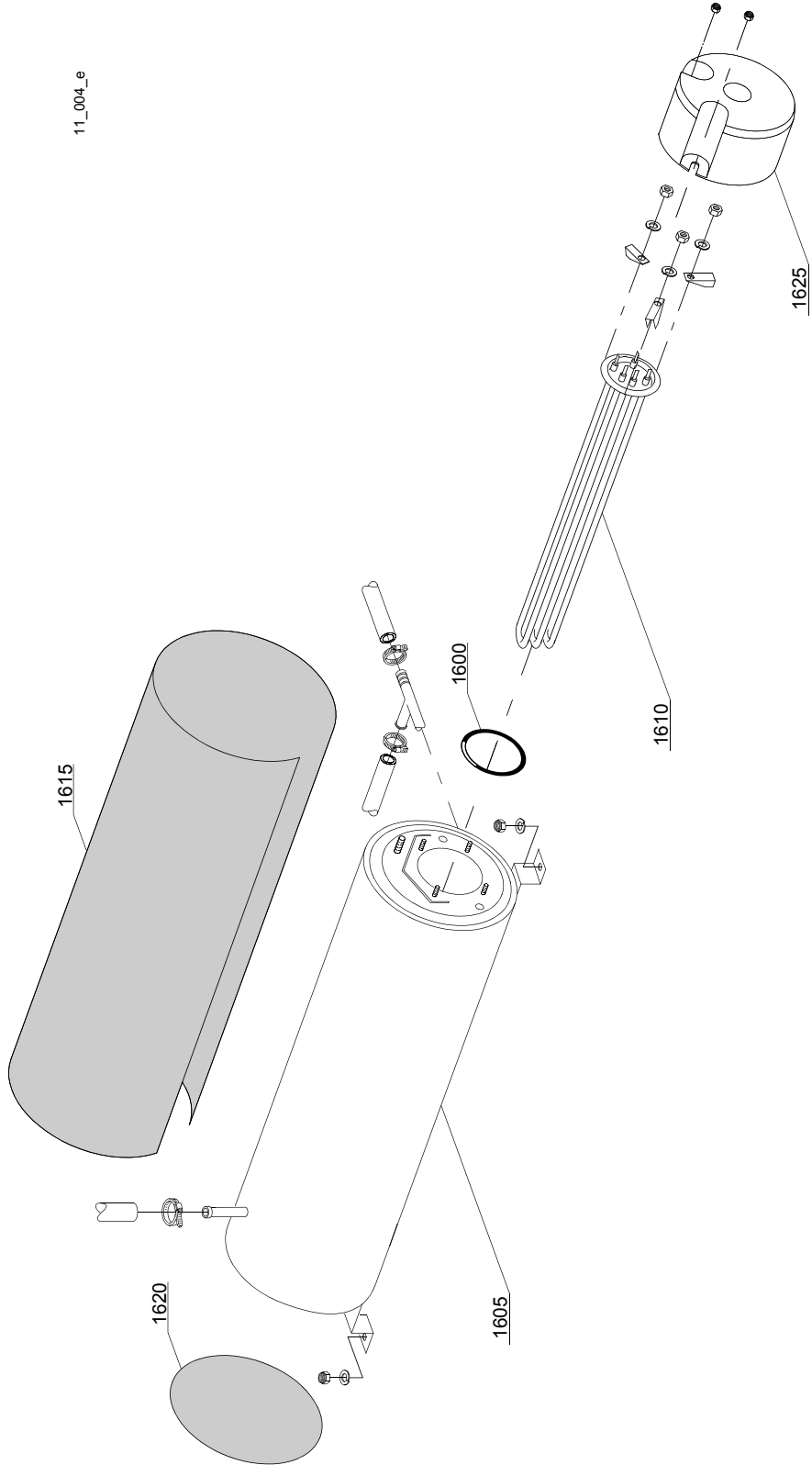

11_004_e

Spare parts

ID	Code	Model	Type	Accessory	Voltage	Description
MODULE:Boiler group						
1600	13015		373U			6225 OR 160 NBR O-ring
1605	22002		373U			Boiler
1610	30001010		373U			6/6,53KW 230/240/3 heating element
1610	30001011		373U			9/9,8KW 230/240/3 heating element
1610	30001011/A		373U			12/13,07KW 230/240V 3 heating element
1615	30002030		373U			Insulation boiler
1620	75205		373U			Ø160 end piece
1625	75311		373U			Heating element cover

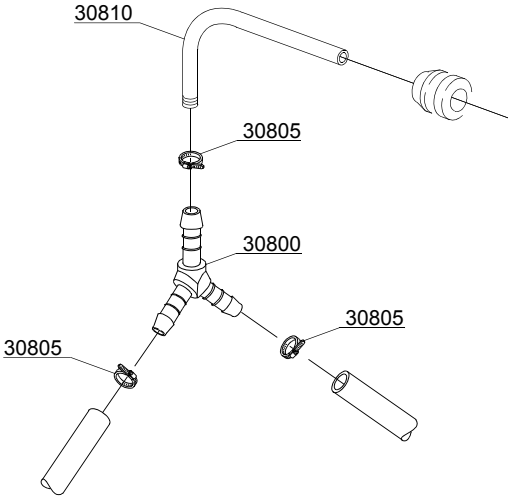

12_003_e

Spare parts

ID	Code	Model	Type	Accessory	Voltage	Description
MODULE:3 ways connection						
30800	540091		373U			Ø12 mm plastic 3 ways connection
30805	11807		373U			12/22 clamp
30810	15168		373U			Rinse pipe

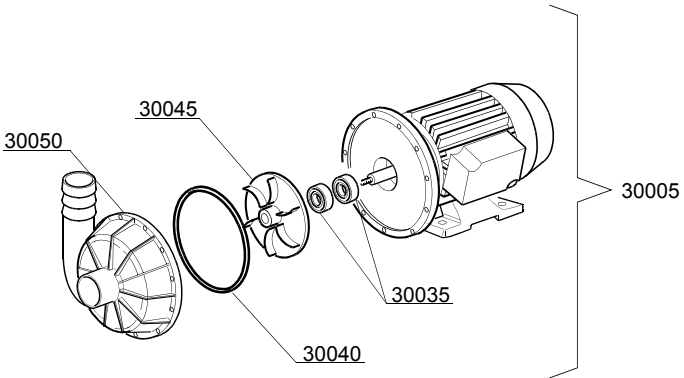
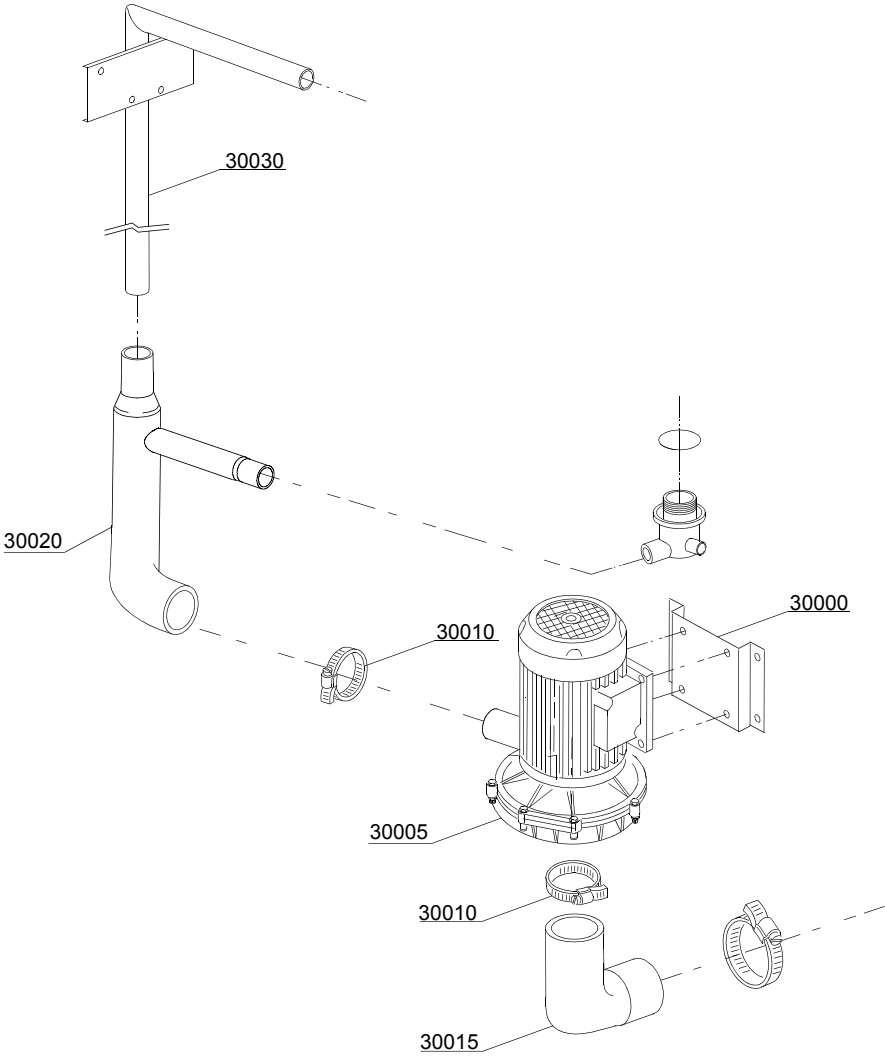

Spare parts

ID	Code	Model	Type	Accessory	Voltage	Description
MODULE:Wash pump group						
30000	11600623		373U			Pump support hanger
30005	22037		373U			2Hp pump
30010	11824		373U			50/70 clamp
30015	11600100		373U			Suction pipe coupling
30020	11600101		373U			Pressure rubber hose
30025	11809		373U			30/45 clamp
30030	11600103		373U			Wash ramp
30035	15080		373U			Rotating seals
30040	10200290		373U			OR 1225 O-ring
30050	10200222		373U			Scroll

14_002_e

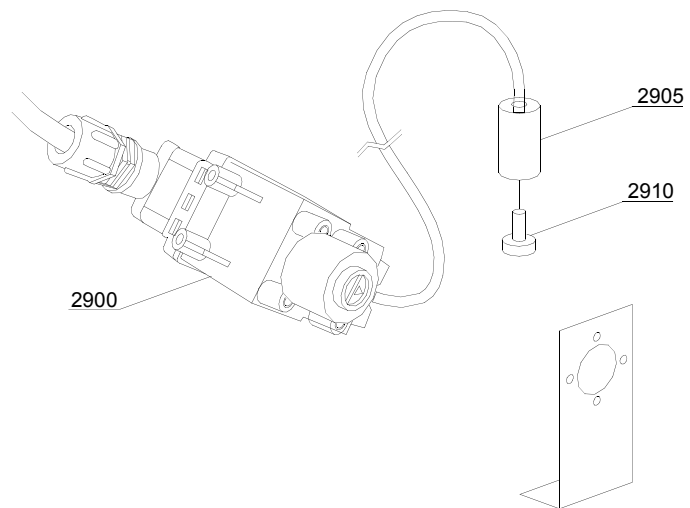
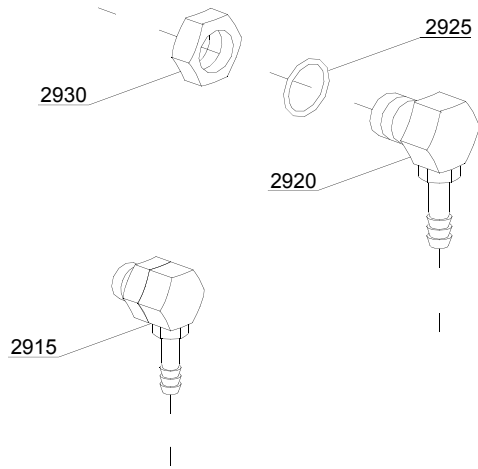

Spare parts

ID	Code	Model	Type	Accessory	Voltage	Description
MODULE:Dosing detergent group						
2900	15108/L		373U	dd		Lang detergent pump
2905	12525		373U	dd		Counter-weight
2910	15058		373U	dd		Small filter
2915	15123		373U	dd		Compleat plastic injector
2920	15148		373U	dd		Steel injector
2925	15159		373U	dd		OR O-ring
2930	10200205		373U	dd		M12x1 stainless steel nut

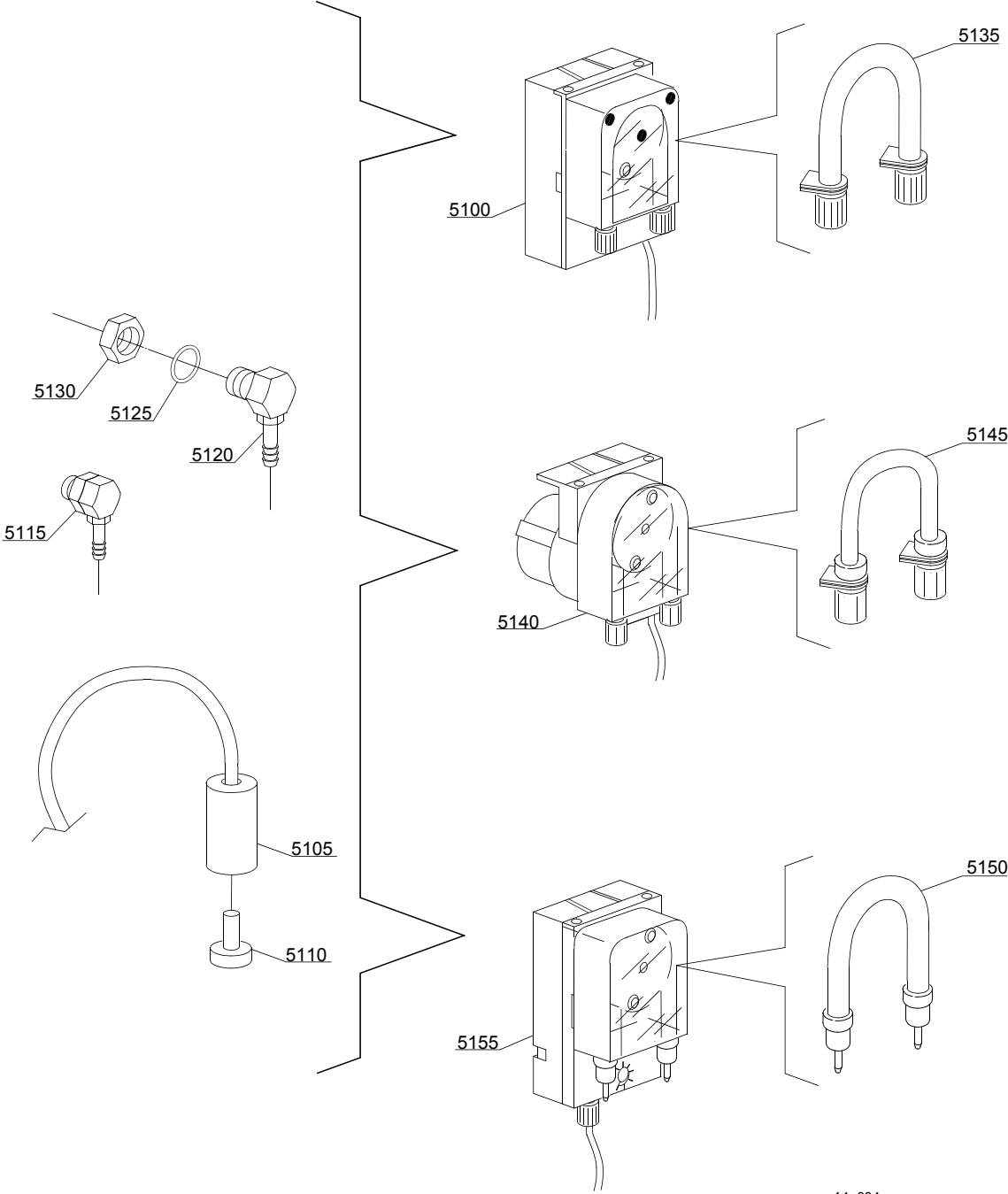

14_004_e

Spare parts

ID	Code	Model	Type	Accessory	Voltage	Description
MODULE:Dosing detergent group						
5100	15985		373U	dd		Seko detergent pump
5105	12525		373U	dd		Counter-weight
5110	15058		373U	dd		Small filter
5115	15123		373U	dd		Complet plastic injector
5120	15148		373U	dd		Steel injector
5125	15159		373U	dd		OR O-ring
5130	10200205		373U	dd		M12x1 stainless steel nut
5135	15185		373U	dd		Ø 10 Seko thermoplastic pipe
5140	15985		373U	dd		Germac detergent pump
5145	15108/E		373U	dd		Ø 8 Germac thermoplastic pipe
5150	15985/A		373U	dd		Ø 10 PLAS CONT thermoplastic pipe
5155	15985		373U	dd		PLAS CONT detergent pipe

15_005_e

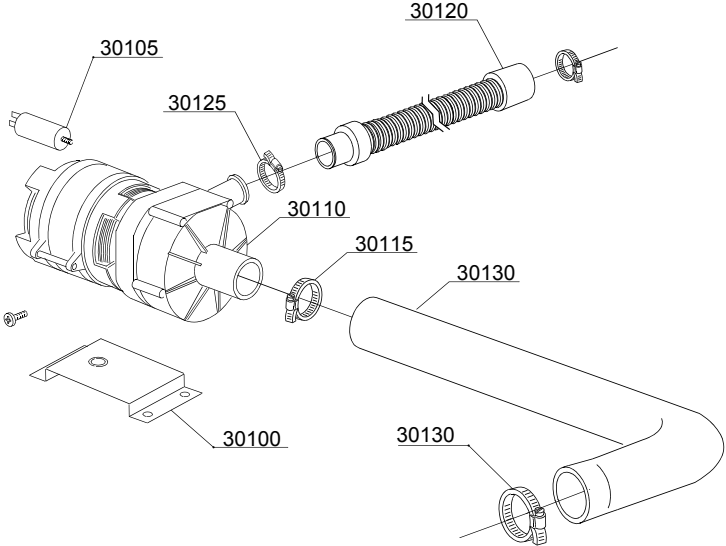

Spare parts

ID	Code	Model	Type	Accessory	Voltage	Description
MODULE:Drain pump group						
30100	440122		373U	dp		Pump support
30105	10702		373U	dp		5 uF condenser
30110	10501/A		373U	dp		190W 230V drain pump
30115	11806		373U	dp		25/40 clamp
30120	10727		373U	dp		Drain pipe
30125	11809		373U	dp		30/45 clamp
30130	18044		373U	dp		Drain rubber elbow

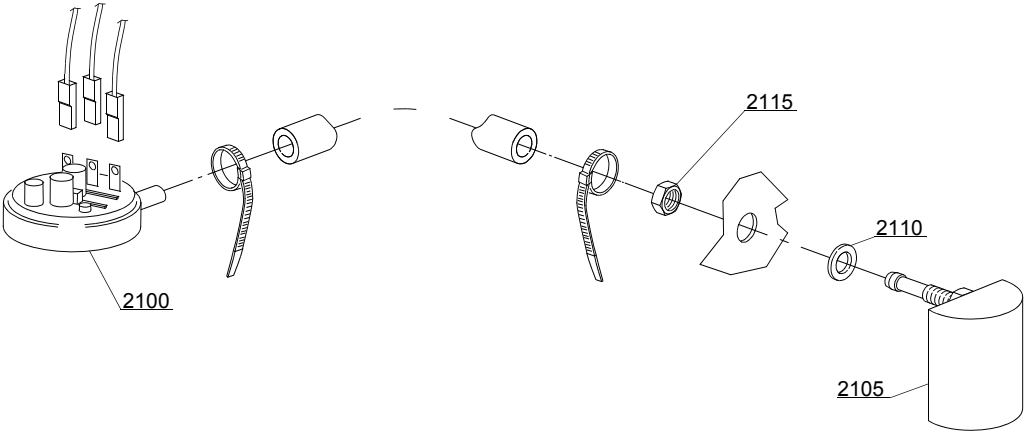

16_001_e

ID	Code	Model	Type	Accessory	Voltage	Description
MODULE:Pressure switch group with air trap						
2100	88110		373U			250-40 pressure switch
2105	10911		373U			Air trap assembly
2110	13301		373U			O-ring
2115	11702		373U			M8 stainless steel nut

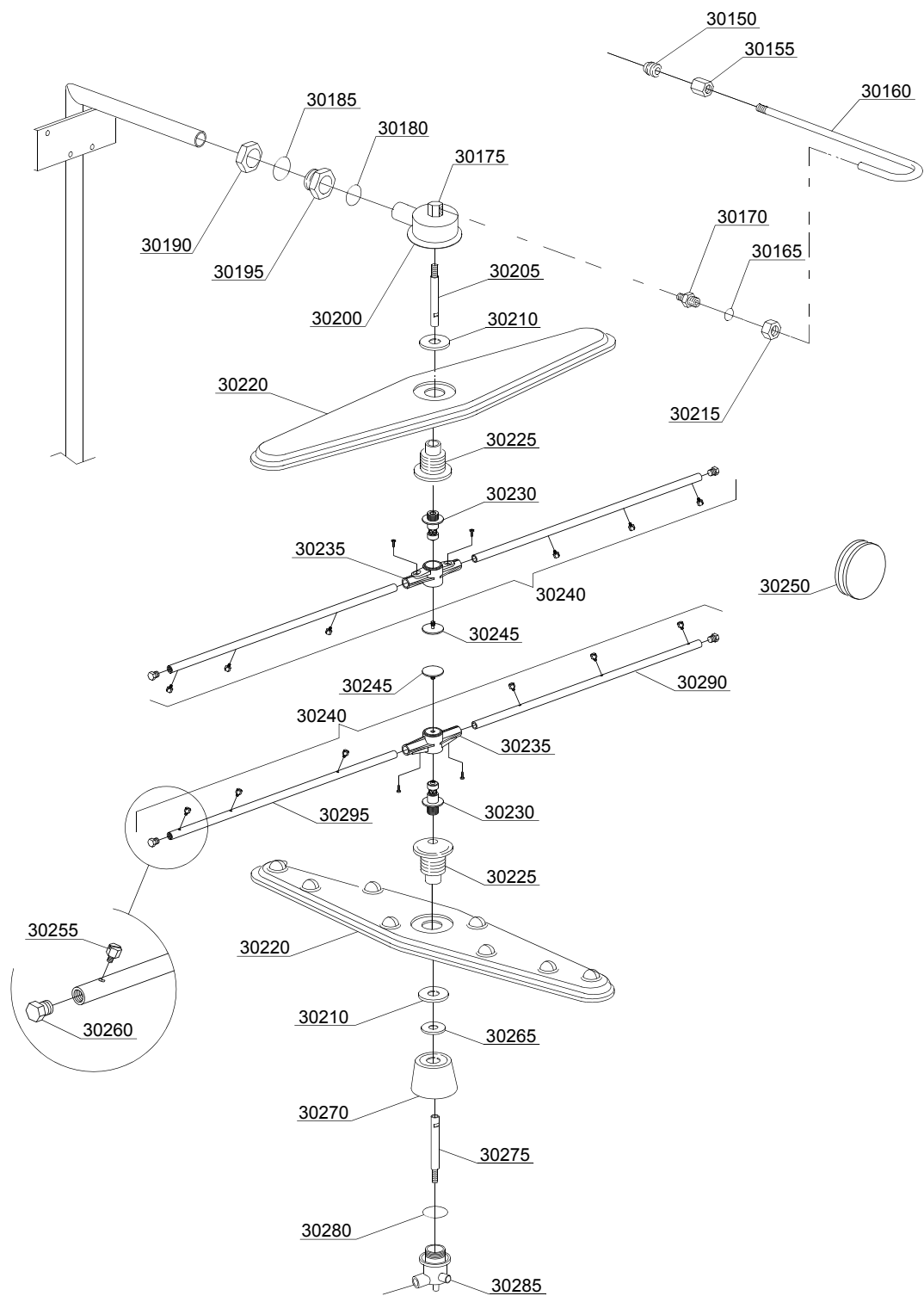

17_125_e

Spare parts

ID	Code	Model	Type	Accessory	Voltage	Description
MODULE:Turret group with rotating arms						
30150	13304		373U			Pipe-pass O-ring
30155	12526		373U			Stainless steel nut coupling
30160	75066		373U			Top rinse pipe
30165	13003		373U			OR 112 NBR O-ring
30170	12006		373U			Ø10 rinse pipe fitting
30175	75319		373U			Rinse elbow
30180	13004		373U			OR 3137 NBR O-ring
30185	13008		373U			OR 147 NBR O-ring
30190	15042/A		373U			Nut
30195	15042		373U			1" 1/4 ring nut
30200	78001		373U			Stainless steel turret for rotor
30205	75322		373U			Top rinse axle
30210	75317		373U			Nut for wash arm bearing
30215	12006/A		373U			Ø10 pipe fitting 3/8x3,5 nut 19 hexagonal
30220	10600900		373U			Wash arm
30225	75320		373U			Wash arm bearing
30230	10651		373U			Rinse axle
30235	10650		373U			Rinse arm
30240	75918		373U			Top/lower rinse arm complete
30245	10652		373U			Rinse arm screw
30250	13316/A		373U			DVGW hole O-ring
30255	560018		373U			Stainless steel rinse nozzle
30260	560017		373U			Rinse arm plug
30265	11600033		373U			Flow reduction ring
30270	11600007		373U			Lower wash arm support
30275	11600021		373U			Lower rinse axle
30280	13015		373U			6225 OR 160 NBR O-ring
30285	500621		373U			Lower coupling
30290	10657		373U			Right rinse arm - stainless steel nozzle
30295	10658		373U			Left rinse arm - stainless steel nozzle