

# MDT2 Service Parts

This is the list of service parts for the MDT2C12-1A ice maker dispenser.

Always have the model and serial number available when looking for a part number as changes do occur and the change may reference the model and/or serial number.

## Table of Contents

Cabinet . . . . .	Page 2
Condensing System . . . . .	Page 3
Water and Dispensing . . . . .	Page 4
Water and Dispensing Part Numbers . . . . .	Page 5
Auger Drive and Evaporator . . . . .	Page 6
Auger Drive and Evaporator Part Numbers . . . . .	Page 7
Control System . . . . .	Page 8
Wiring Diagram . . . . .	Page 9

# MDT2 Service Parts

## Cabinet

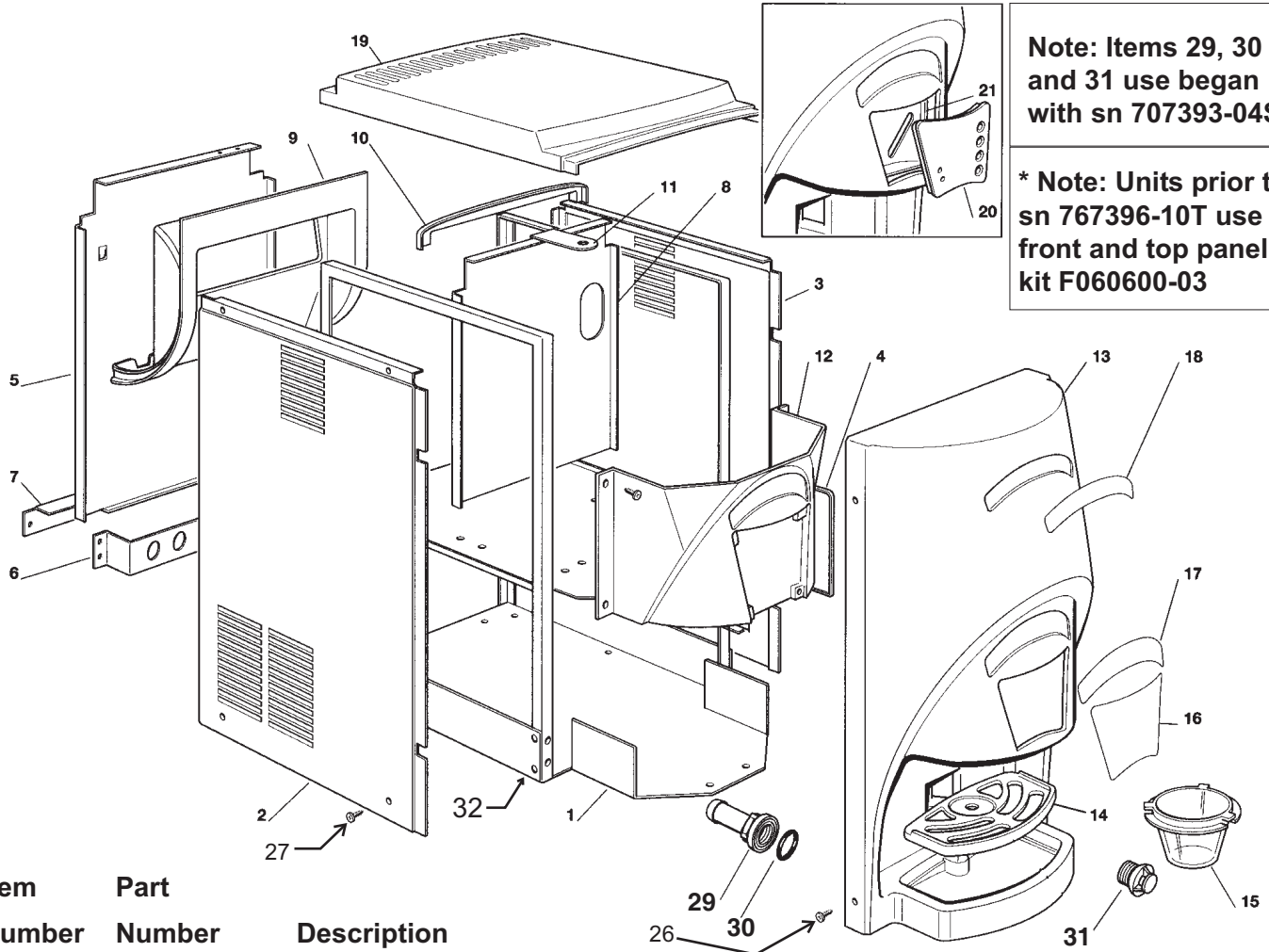

Note: Items 29, 30 and 31 use began with sn 707393-04S

\* Note: Units prior to sn 767396-10T use front and top panel kit F060600-03

Item Number	Part Number	Description
1	F650780-00	Foam pad
2	F721737-00	Left Side Panel
3	F721738-00	Right Side Panel
4	F721763-00	R Pcb Service Panel
5	F702260-00	Rear Panel
6	F702259-00	Metal Bracket For Fitting
7	F702269-00	Cover For Fitting Bracket
8	F702257-00	Metal Divider
9	F660669-00	Condenser Shroud
10	F660674-00	Plastic Bracket
11	F702270-00	Ice Spout Bracket
12	F660672-00	Dispense Board Frame
13	F660812-01	Front Panel, incl. items 16, 17, 18*
14	F650729-00	Grill:Sink
15	F660675-00	Dispensing Spout
16	F650753-05	Label - Ice & Water
17	F650753-01	Label
18	F650753-00	Scotsman Logo
19	F660811-00	Top Panel*
20	F660699-00	PCB cover
21	F660700-00	PCB housing
26	F470000-03	Screw
	F650730-00	Cap for screw
	F650730-01	Washer for screw
27	F470002-11	Side panel screw
28	F470030-50	Back panel screw
29	F660219-01	Drain fitting
30	F640134-00	O-ring
31	F660211-01	Drain top
32	F650780-00	Foam pad, under base

# MDT2 Service Parts

## Condensing System

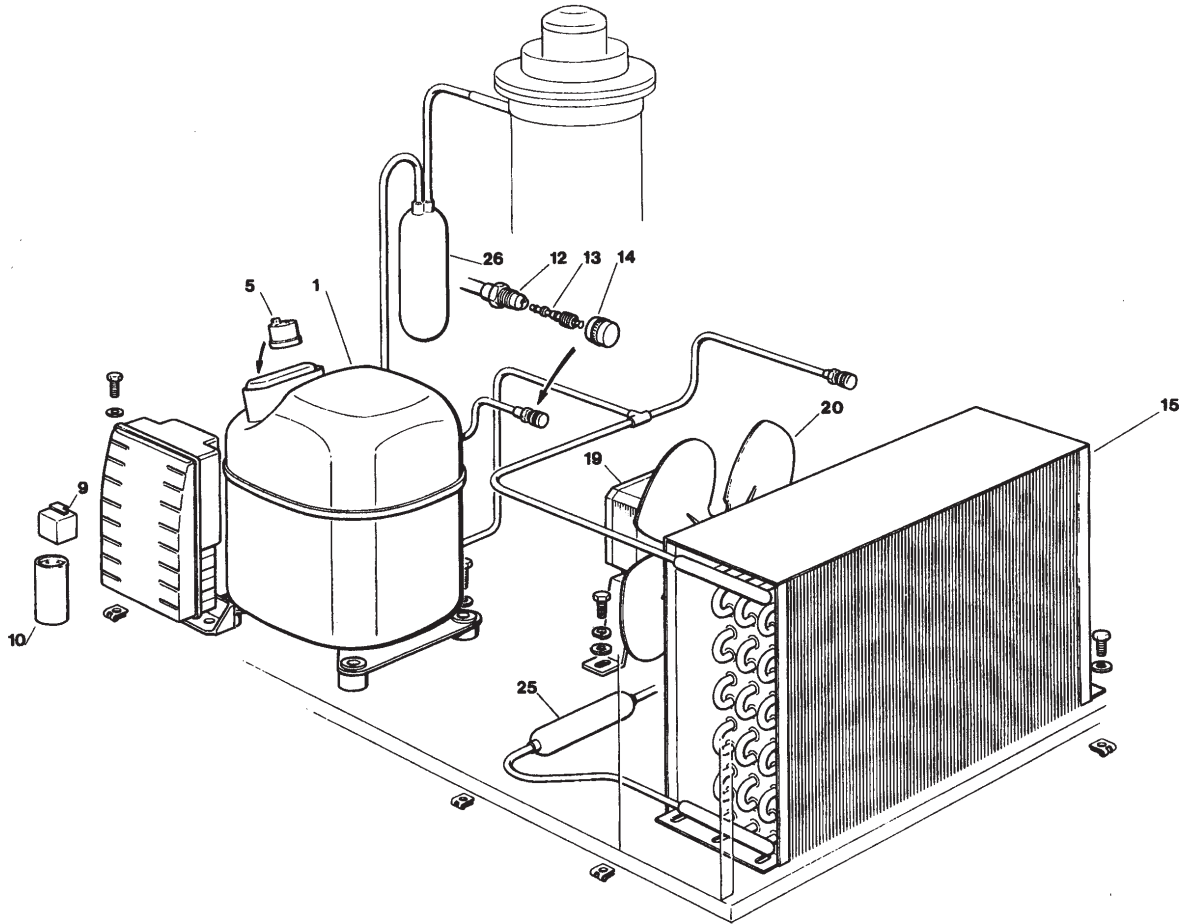

Item Number	Part Number	Description
1	F670101-06	Compressor assy
5	F620058-68	Protector
9	F620057-59	Start Relay
10	F620167-55	Start Capacitor (315 mfd)
12	F650109-00	Valve Body
13	F670012-00	Valve Piston
14	F650106-00	Valve Cap
15	F620439-00	Air Cooled Condenser
19	F620419-03	Fan Motor
20	F620419-33	Fan Blade
25	F630003-06	Drier
26	F784469-09	R Suction Line/Accumulator

# MDT2 Service Parts

## Water and Dispensing

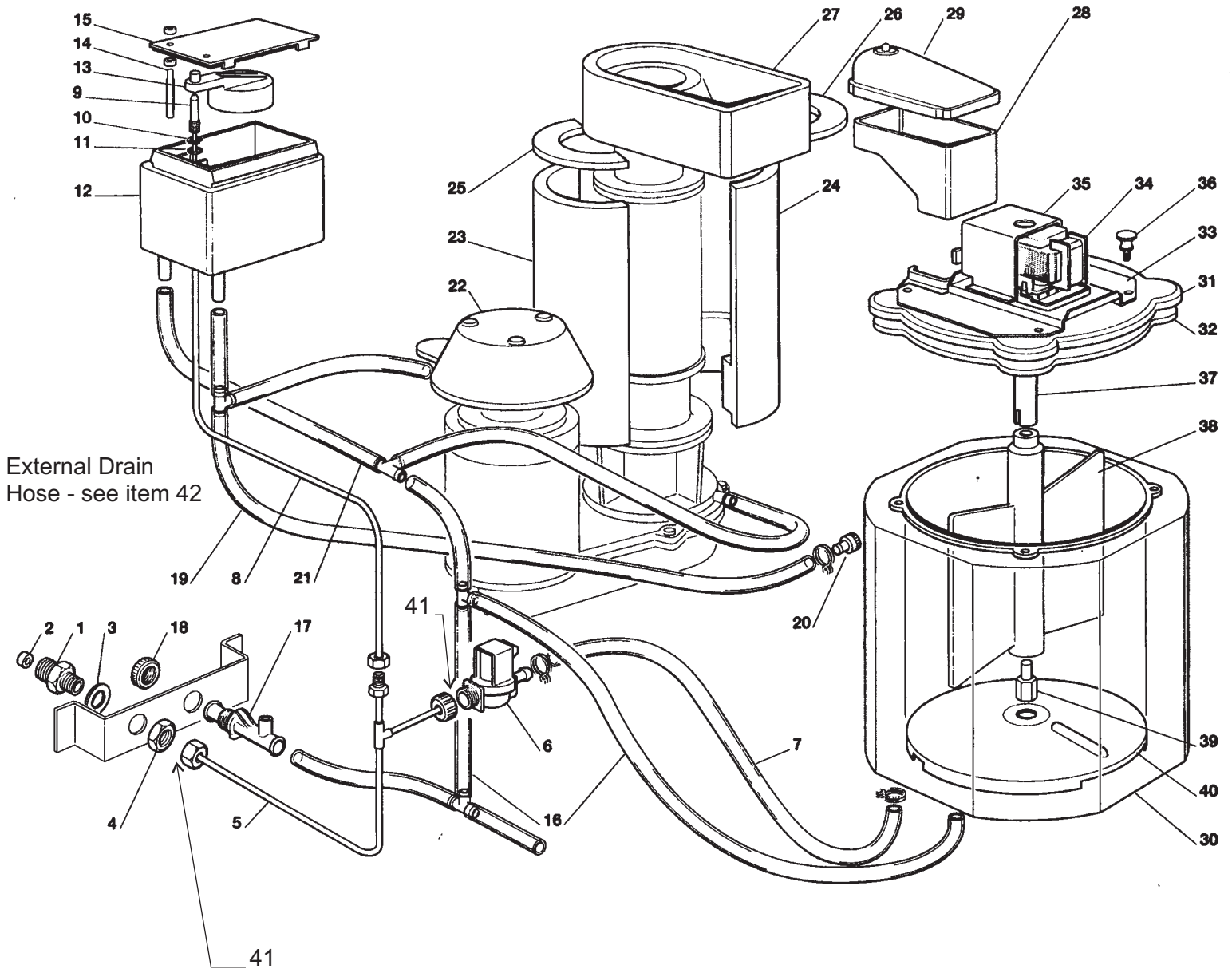

# MDT2 Service Parts

## Water and Dispensing Part Numbers

Item Number	Part Number	Description	Item Number	Part Number	Description
1	F733205-01	Water Inlet Fitting	34	12-1610-01	Dispensing Motor
2	F650104-00	Strainer	35	F721729-00	Cover, Dispensing Motor
3	F400052-00	Fiber Washer	36	03-0727-10	Screw
4	F400053-00	Nut	37	02-3241-01	Shaft
5	No Number	Copper Water Inlet Tube	38	A37893-001	Ice Agitator
6	F650105-59	Water Inlet Valve	39	02-3033-01	Pin, Vane
7	F610194-03	Plastic Tube	40	A38272-001	Bin Bottom
8	No Number	Copper Water Inlet Tube	41	F640076-13	Rubber washer
9	F783153-00	Nozzle	42	F060513-01	External drain hose
10	F460038-02	Clip Ring			
11	F640100-00	O Ring			
12	F793126-01	Water Reservoir assy			
13	F660585-00	Float Valve assy			
14	F724215-06	Water Level Metal Pin			
15	F660363-00	Water Reservoir Cover			
16	F610194-01	Plastic Tube			
17	F660224-00	Water Drain Fitting			
18	F660535-00	Plastic Ring Nut			
19	F610194-04	Plastic Tube			
20	F650106-00	Valve Cap			
	F650109-00	Valve Body			
21	F610194-02	Plastic Tube			
22	F660670-00	Gear Motor Plastic Cover			
23-24	F060551-04	Insulation			
25-26	F650723-01	Insulation			
27	F650723-00	Spout Insulation			
28	F660695-00	Ice Spout			
29	F660694-00	Ice Spout Cover			
30	A36118-020	Storage Bin			
31	F650747-00	Insulation, Storage Bin Cover			
32	F660662-00	Cover, Storage Bin			
33	A35473 -001	Bracket, Dispensing Motor			

# MDT2 Service Parts

## Auger Drive and Evaporator

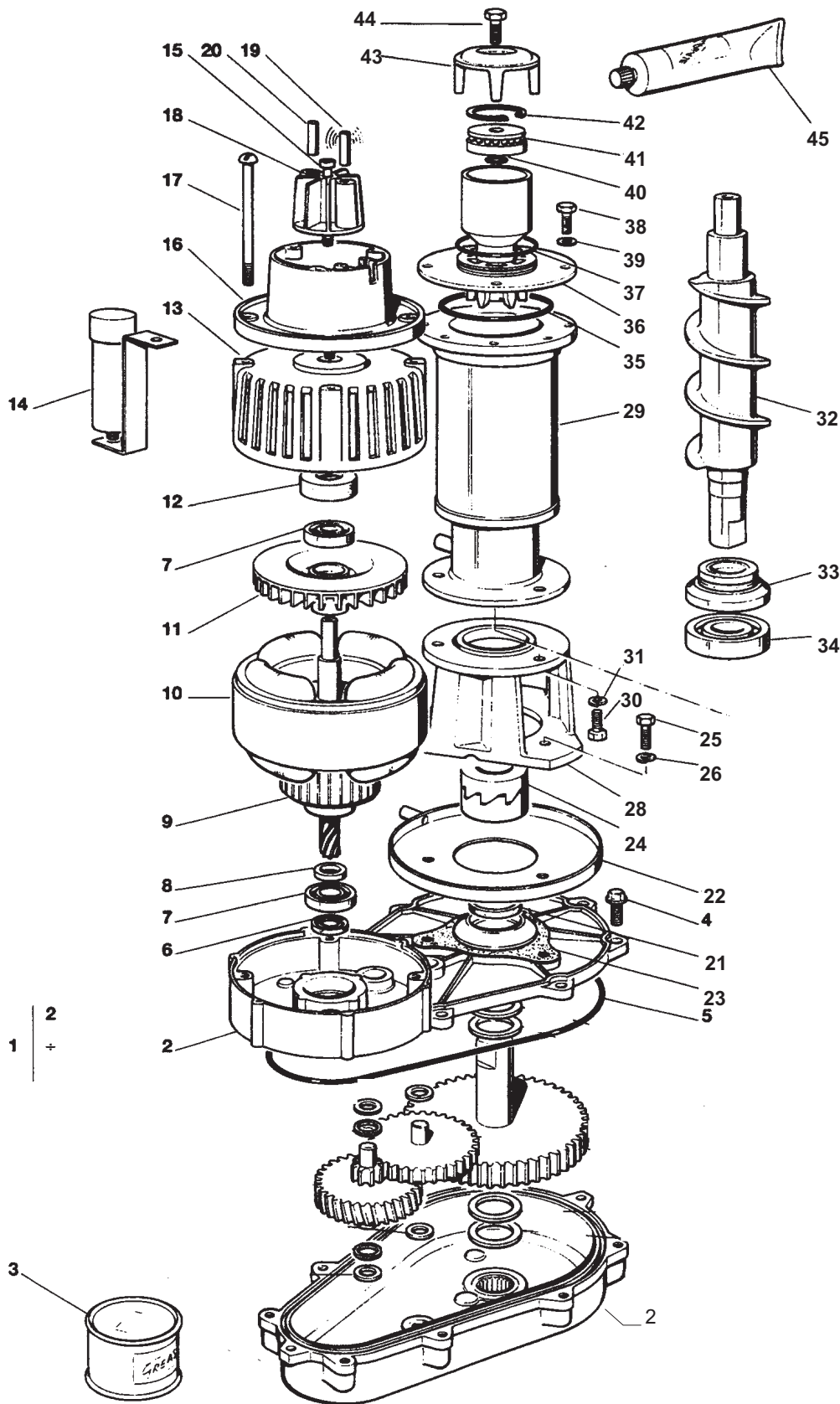

# MDT2 Service Parts

## Auger Drive and Evaporator Part Numbers

Item Number	Part Number	Description	Item Number	Part Number	Description
1	F794225-14R	Gear Reducer assy	36	F060661-00	Ice Breaker
2	F001015-01	Gear Case assy			includes items 37, 41, 42
3	F060294-01	Grease (1 Kg)	37	F640041-27	O Ring
4	03-1251-01	Screw	38	F420019-00	Screw
5	02-1505-00	O Ring	39	F440015-04	Washer
6	F640083-00	Grease Seal	40	F640041-25	O Ring
7	F651056-00	Bearing	41	F670041-00	Top Bearing
8	F441800-09	Trust Washer	42	F650297-00	Clip Ring
9	F794123-03	R Rotor assy	43	F650725-00	Ice Sweep
10	F620394-01	Stator assy	44	F420030-00	Screw
11	F764001-00	Fan Blade	45	F263612-00	Water Proof Grease
12	F640095-00	Rubber Insert			
13	F794226-01	Drive Motor Cover			
14	F620292-00	Capacitor			
15	03-1403-77	Screw			
16	F650515-01	Plastic Housing			
17	F423872-01	Screw			
18-19-20	F784476-00	Magneto Holder assy			
21	F640019-01	Grease Seal			
22	F784062-00	Drip Tray			
23	F640060-00	Gasket			
24	F060359-00	Coupling			
25	F421052-00	Screw			
26	F440015-04	Washer			
27	NO NUMBER	Freezer assy			
28	F764010-00	aluminum Adapter			
29	F784541-01	Evaporator			
30	F421591-00	Screw			
31	F440015-04	Washer			
32	F650727-00	Auger			
33	02-1300-01	Water Seal			
34	F670011-01	Lo Bearing			
35	F640041-28	O Ring			

# MDT2 Service Parts

## Control System

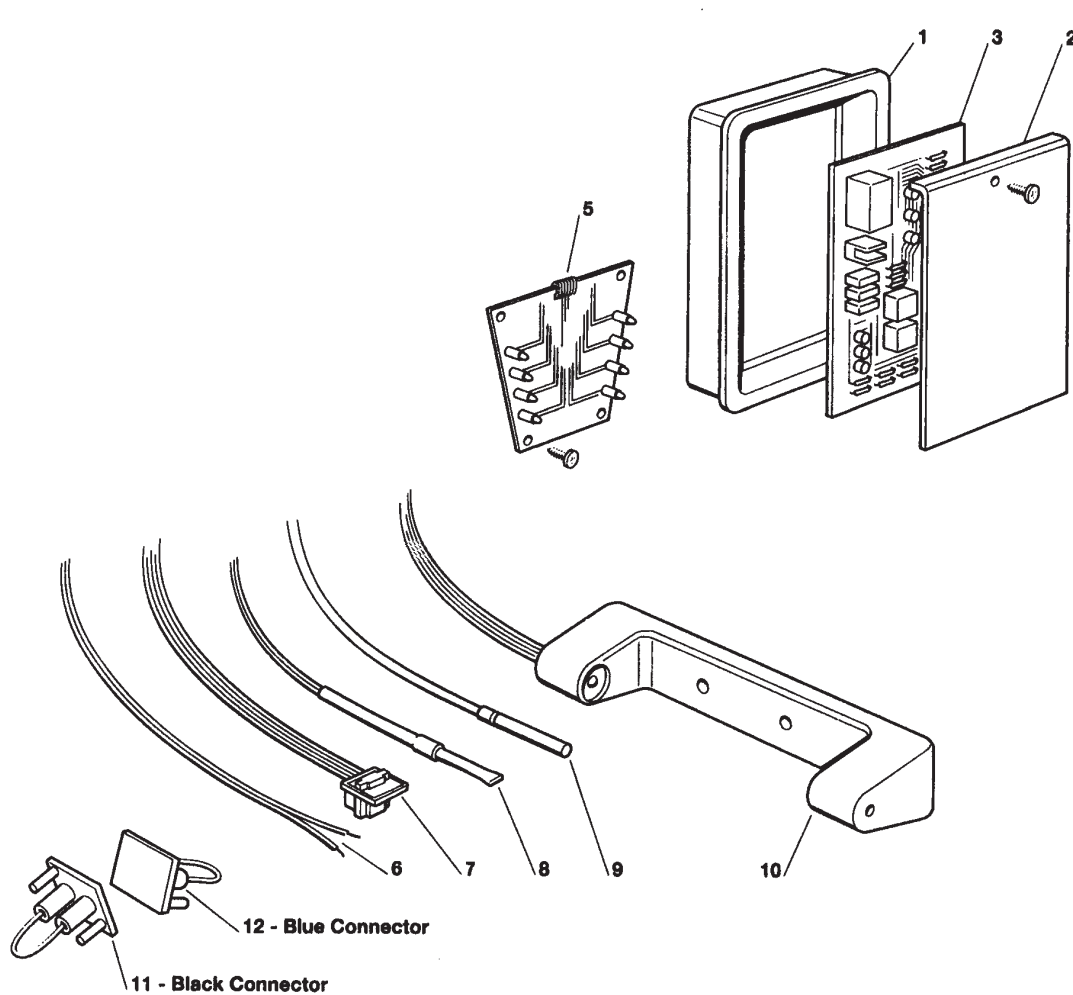

Item Number	Part Number	Description
1	F705231-00	Box only
2	F705332-00	Cover
3	F620448-05	P.C. Board & Box assy
5	F060613-00	Dispensing P.C.B.
6	F620404-13	Water Level Sensor
7	F620404-03	Hall Effect Sensor
8	F620404-11	Condenser Temp. Sensor
9	F620404-10	Evaporator Temp. Sensor
10	F650674-02	Ice Level Control assy
11	F620448-03	Dispensing Sensor Tx (Black)
12	F620448-02	Dispensing Sensor rx (Blue)
13	F620448-04	Harness for dispensing sensor
14	F630119-04	Contactors (not shown)



# MDT2 Service Parts

## Wiring Diagram

WIRING DIAGRAM (MACHINE OPERATING)

BU - BLUE  
 W - WHITE  
 BK - BLACK  
 GR - GREEN  
 R - RED  
 B - BROWN  
 LB - Light Blue

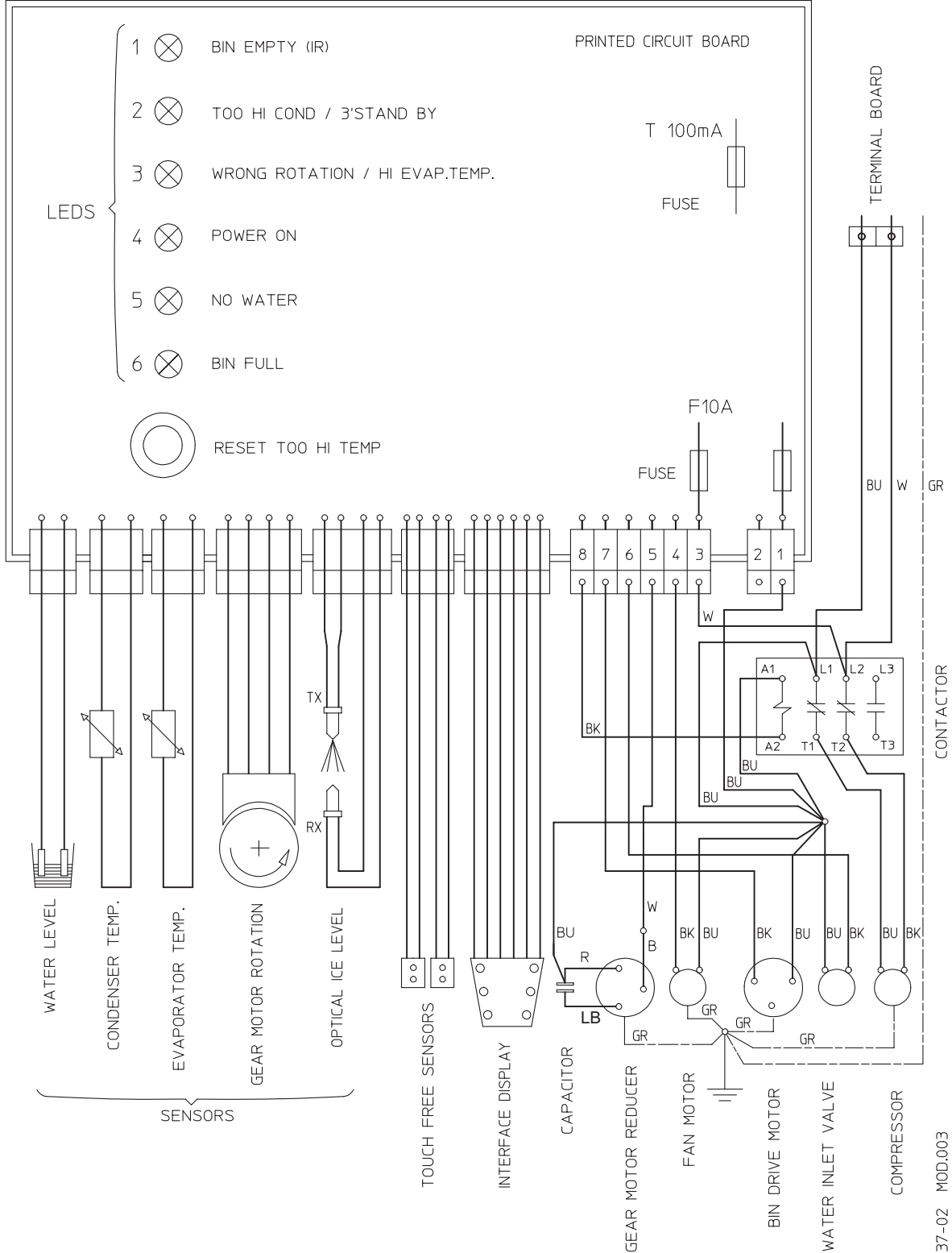

050537-02 MOD.003