

ITEM	DESCRIPTION	SPARES No
1	BASE PANEL	531610190
2	OUTER TOP	531610170
3	OUTER SIDE LH	731600000
4	OUTER SIDE RH	531610250
5	CONTROL PANEL	731600001
6	INNER BACK PANEL	731580004
7	OUTER BACK PANEL ASSEMBLY	535980003
7-1	BACK PANEL COVER PLATE	535980004
8	INNER SIDE LH	531610390
9	INNER SIDE RH	531610350
10	INNER TOP PANEL	531610200
11	COOLING PLATE	731600002
12	WIRE GRID C/W HANDLES	535980006
12-1	HANDLE & DISC FOR GRID	535900010
13	DRIP TROUGH	731600003
14	DRIP TRAY	731600004
15	FRONT FACIA	731600005

CLEARED FOR PRODUCTION

ISSUE	MOD No	ALTERATION	DRAWN BY	DATE
A	1305	Production issue	S McGuinness	15/11/11

IF IN DOUBT ASK
DO NOT SCALE
FIRST ANGLE PROJECTION

UNLESS OTHERWISE SPECIFIED:
DIMENSIONS ARE IN MILLIMETERS
TOLERANCES:
LINEAR: ±0.5mm
ANGULAR: ±0.5 DEG

DEBUR AND
BREAK SHARP EDGES

WEIGHT: 54892.87g



DRAWN: S McGuinness	PRODUCT E3512 Grill	
DATE: 17/10/11	TITLE SPARES DIAGRAM FITMENTS	
SCALE: 1:5	DRAWING NUMBER	ISSUE
MATL:	AD48966	a
THICKNESS:	FINISH:	PART No:
BIN No:		

© NO REPRODUCTION OR PUBLICATION OF THIS DRAWING MAY BE MADE AND NO ARTICLE MAY BE MANUFACTURED OR ASSEMBLED IN ACCORDANCE WITH THIS DRAWING WITHOUT PRIOR WRITTEN CONSENT. THIS PROHIBITION IS A TERM OF ANY CONTRACT RELATING TO THIS DRAWING. RIGHTS RESERVED UNDER THE COPYRIGHT ACT 1956 AS AMENDED BY THE DESIGN COPYRIGHT ACT 1968

1 2 3 4 5 6 7 8

A

B

C

D

E

F

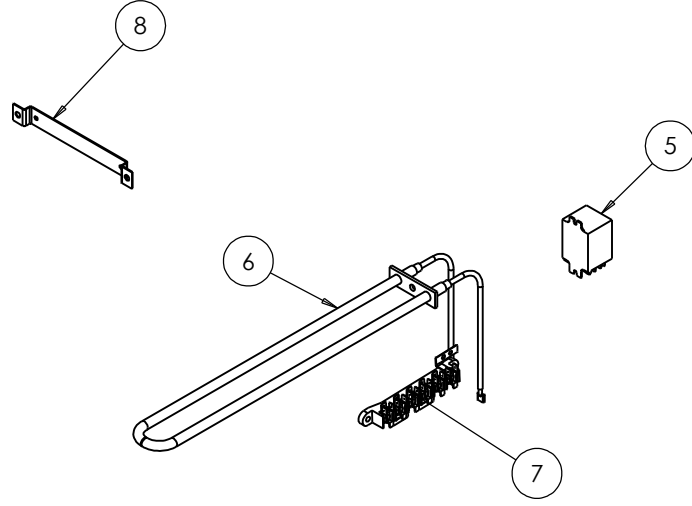

ITEM	DESCRIPTION	Qty PER UNIT	SPARES No
1	ENERGY REGULATOR	1	737630011
2	CONTROL KNOB	1	731610000
3	NEON INDICATOR	1	735400180
4	RELAY BRACKET	1	731580009
5	RELAY UNIT	1	731580008
6	ELEMENT	6	731540400
7	TERMINAL BLOCK	3	731580006
8	MAINS TERMINAL BLOCK	2	731580010
9			

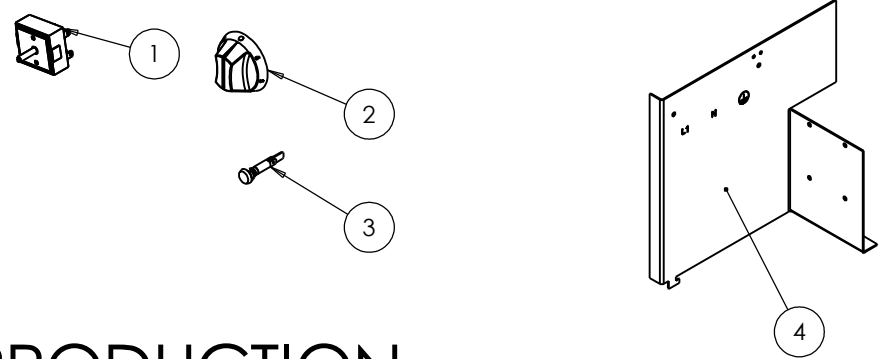

CLEARED FOR PRODUCTION

ISSUE	MOD No	ALTERATION	DRAWN BY	DATE
A	1305	PRODUCTION ISSUE	S McGuinness	15/11/11
1				

IF IN DOUBT ASK
DO NOT SCALE
FIRST ANGLE PROJECTION

UNLESS OTHERWISE SPECIFIED:
DIMENSIONS ARE IN MILLIMETERS
TOLERANCES:
LINEAR: ±0.5mm
ANGULAR: ±0.5 DEG

DEBUR AND
BREAK SHARP EDGES

WEIGHT: 54892.87g



DRAWN: S McGuinness	PRODUCT
DATE: 14/10/2011	TITLE
SCALE: 1:3	
MATL:	DRAWING NUMBER
THICKNESS:	FINISH:
BIN No:	PART No:

E3512 GRILL	
SPARES DIAGRAM CONTROLS	
AD48970	A

© NO REPRODUCTION OR PUBLICATION OF THIS DRAWING MAY BE MADE AND NO ARTICLE MAY BE MANUFACTURED OR ASSEMBLED IN ACCORDANCE WITH THIS DRAWING WITHOUT PRIOR WRITTEN CONSENT. THIS PROHIBITION IS A TERM OF ANY CONTRACT RELATING TO THIS DRAWING. RIGHTS RESERVED UNDER THE COPYRIGHT ACT 1956 AS AMENDED BY THE DESIGN COPYRIGHT ACT 1968