

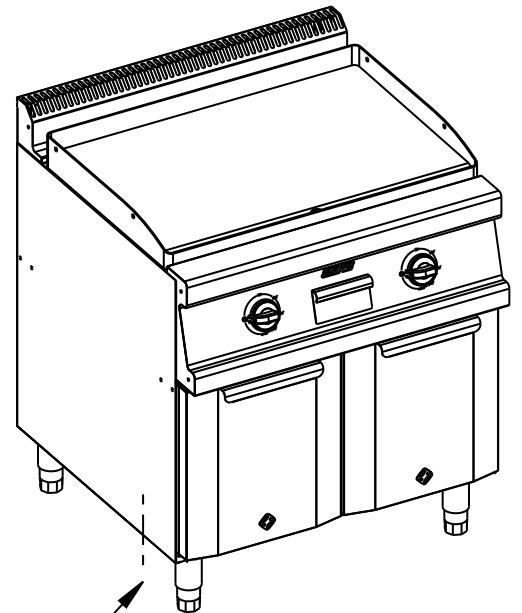

**Applus®**  
LGAI  
Organismo  
Notificado  
**0370**

**AENOR**  
Organismo  
Notificado  
**0099**

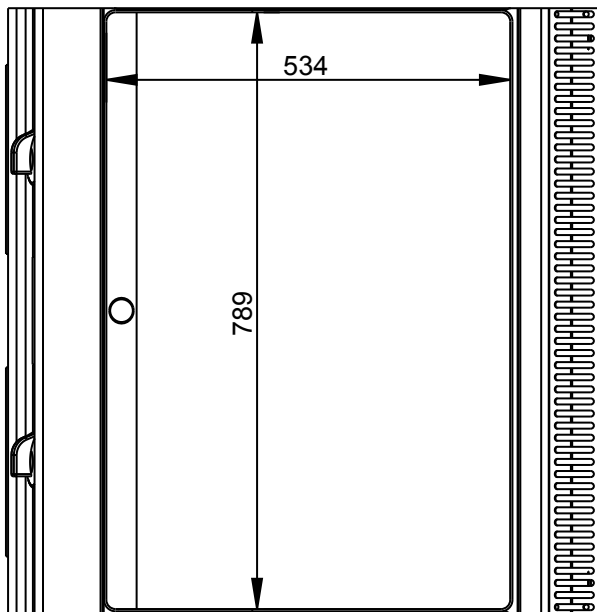
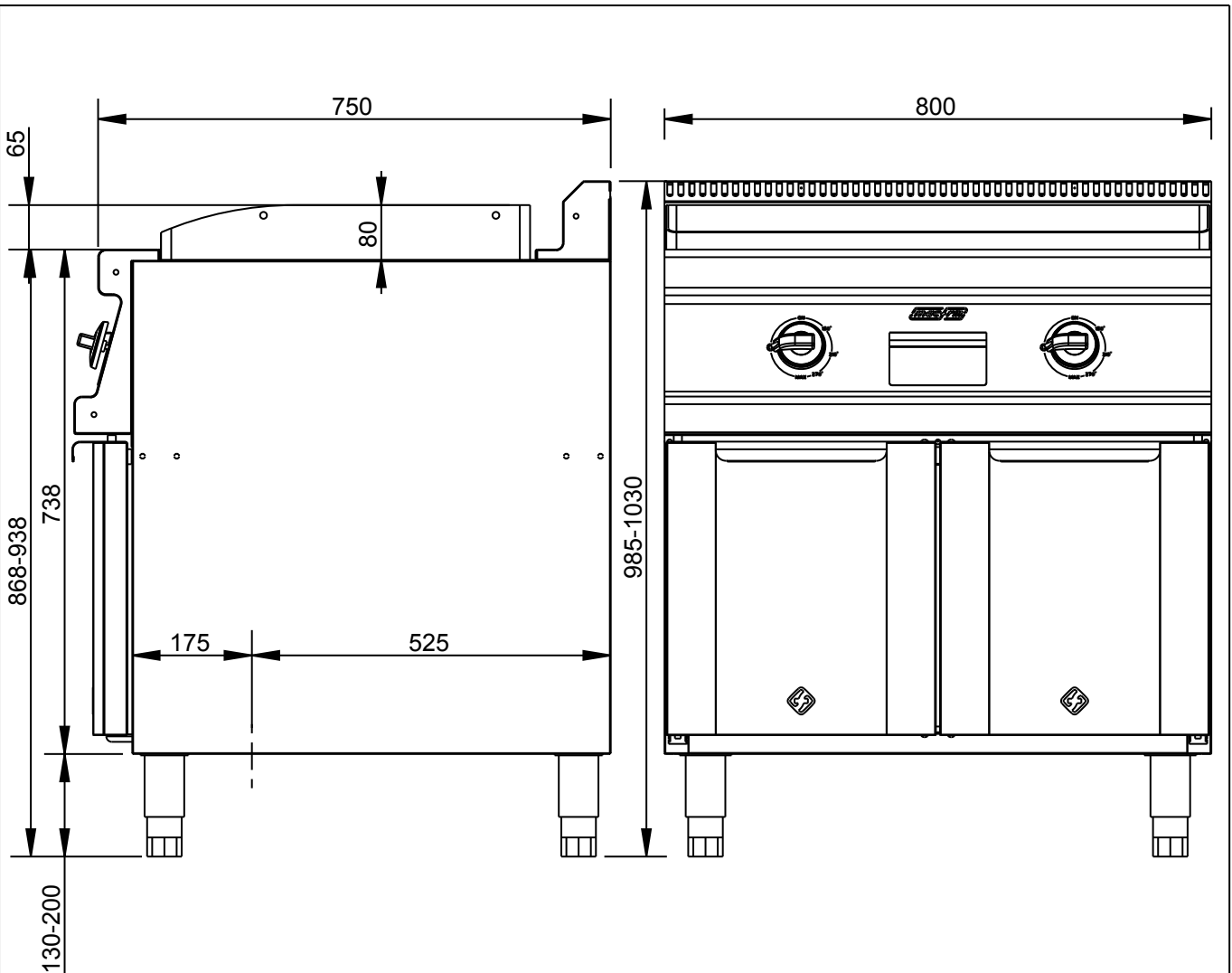

ENTRADA  
CORRIENTE

POTENCIA: 8.000 W 400/III

FUNDADA EN 1878  
**MAS BAGA**  
GRANDES COCINAS

**EURAST**

**mac-fin**

TOLERANCIAS GENERALES: ± 0.5 mm



FAMILIA: COCINAS 2008

FECHA: 10/01/11

MODELO: 3626

PESO(Kg): 95.490

DENOMINACION:  
FRYTOP 800X750 ELECTRICO

ESCALA:  
1/10

MATERIAL:  
INOX

CODIGO:  
3626



**Applus®**  
LGA1  
Organismo  
Notificado  
**0370**

**AENOR**  
Organismo  
Notificado  
**0099**

FUNDADA EN 1878  
**MAS BAGA**  
GRANDES COCINAS

**EURAST**

**mac-fin**

TOLERANCIAS GENERALES: ± 0.5 mm

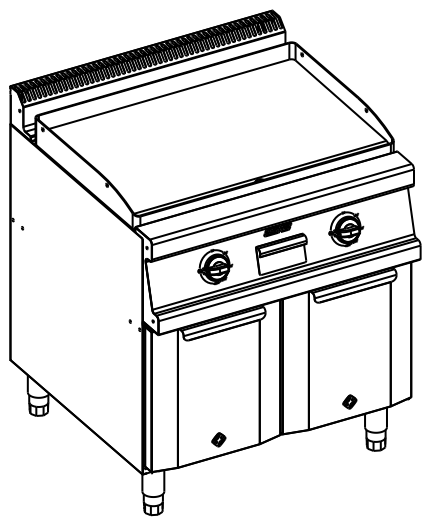

QT	COD	DESCRIPCION
1	350563	BASE 800 X 750
2	350503	BISAGRA
2	C5520799	BORNE PHOENIX AZUL UK-10N
6	C5520801	BORNE PHOENIX GRIS UK-10N
2	C5520800	BORNE PHOENIX VERDE-AMA.UK-10N
2	350505M	CONJ.PUERTA COCINA DCHA/IZQ.
1	362149C	CONJUNTO CUBETA / CAJON FT
1	362639C	CONJUNTO FRONTAL FT.ELEC. 800
2	348173PM	CONJUNTO MANDO ELECTRICO
1	340122C	CONJUNTO PETO 800
2	361633C	CONJUNTO PROTECTOR BULBO ELEC.
2	C5123179	CONTACTOR 25A 230V
1	350565	FRONTAL INFERIOR 800
1	332648	GUIA CONTACTORES 400
1	332748	GUIA CONTACTORES 800
2	6084	IMAN
1	350508	LATERAL DERECHO 750
1	350509	LATERAL IZQ. 750
2	350104	OMEGA COCINA 800
4	C6260511	PATA INOX 130-200 (S. F)
2	C5120219	PILOTO REDONDO ROJO D.5.5
1	362406P	PLANCHA CR LISA 795X540
1	300133	RAMPA CAIDA ACEITE
2	C5520049	REGLETA MOTOR
2	C5421619	RESISTENCIA 4000 W FT600/750
1	490276	SOPORTE GUIA 332748-REG.MOTOR
2	490294	SOPORTE REGLETA MOTOR
2	362476	SOPORTE VALV.MINISIT-CONTACTOR
1	3505991	TAPA TUBOS ENTRADA CORRIENTE
2	2221	TERMOSTATO 320°
1	330213	TRASERO 800

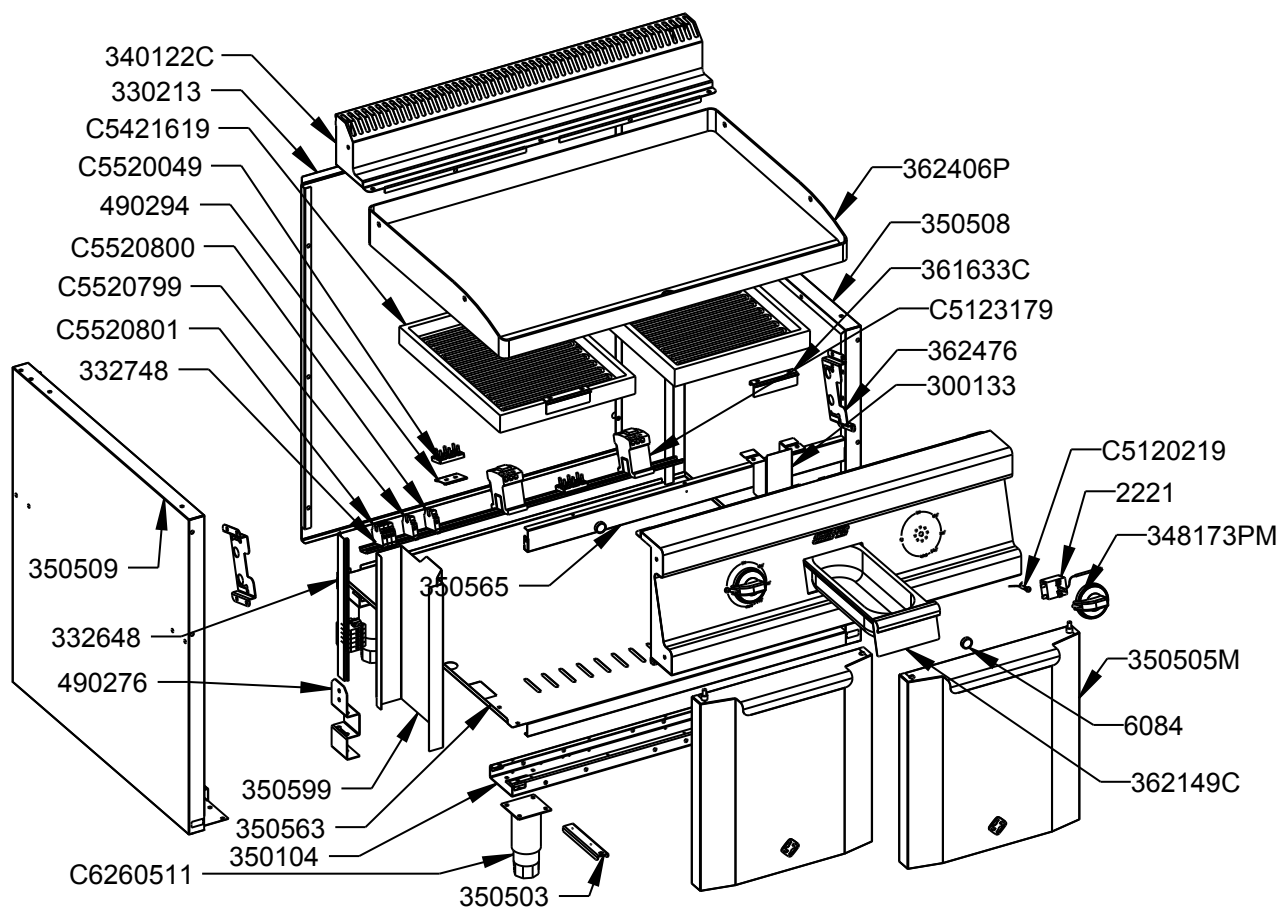

FAMILIA: COCINAS 2008

FECHA: 10/01/11

MODELO: 3626

PESO(Kg): 95.490

DENOMINACION:  
FRYTOP 800X750 ELECTRICO

ESCALA:  
1/15

MATERIAL:  
INOX

CODIGO:  
3626



**Applus®**  
LGA1  
Organismo  
Notificado  
**0370**

**AENOR**  
Organismo  
Notificado  
**0099**



TOLERANCIAS GENERALES: ± 0.5 mm

QT	COD	DESCRIPCION	FAB.	MATERIAL	DATA	PESO
8	TESTA35	ANGULO TESTATINA 35	SI	INOX 0.6	29/08/07	0.004
4	TESTA70	ANGULO TESTATINA 70	SI	INOX 0.6	29/08/07	0.008
2	TESTA140	ANGULO TESTATINA 140	SI	INOX 0.6	29/08/07	0.016
1	350563	BASE 800 X 750	SI	INOFER 0.8	21/12/09	3.698
2	350503	BISAGRA	SI	INOFER 1.2	20/09/07	0.067
2	350505M	CONJ.PUERTA COCINA DCHA/IZQ.	SI	INOX	26/05/08	3.467
1	362149C	CONJUNTO CUBETA / CAJON FT	SI	INOX	27/06/08	0.775
1	362639C	CONJUNTO FRONTAL FT.ELEC. 800	SI	INOX	26/10/09	4.620
1	340122C	CONJUNTO PETO 800	SI	INOX	16/09/08	1.892
2	361633C	CONJUNTO PROTECTOR BULBO ELEC	SI	INOX	11/01/11	0.046
2	350518	CONTRAPUERTA ARMARIO COCINA	SI	INOFER 1.2	25/02/10	1.975
1	362639	FRONTAL FRYTOP ELECT.800x750/900	SI	INOX 1.2	26/10/09	4.048
1	350565	FRONTAL INFERIOR 800	SI	INOFER 0.8	15/06/10	0.394
1	362148	GUIA CAJON FT(GN 2/8-65)	SI	INOFER 0.8	24/10/08	0.280
1	332648	GUIA CONTACTORES 400	SI	GALVA 0.8	30/10/08	0.094
1	350508	LATERAL DERECHO 750	SI	INOFER 0.8	27/02/09	4.447
1	350509	LATERAL IZQ. 750	SI	INOFER 0.8	27/02/09	4.447
2	350104	OMEGA COCINA 800	SI	GALVA 1.5	13/11/08	1.495
1	340122	PETO SOBRE 800X750/900	SI	INOX 1.2	07/04/08	1.597
2	361633	PROTECTOR BULBO ELEC.	SI	INOX 0,8	11/01/11	0.015
2	350505	PUERTA ARMARIO COCINA	SI	INOX 0.8	01/10/07	1.470
1	300133	RAMPA CAÍDA ACEITE	SI	INOFER 0.8	18/07/08	0.118
1	490276	SOPORTE GUIA 332748-REG.MOTOR	SI	GALVA 1.5	03/12/10	0.016
2	3616331	SOPORTE PROTECTOR BULBO ELEC.	SI	INOFER 0.8	11/01/11	0.031
2	490294	SOPORTE REGLETA MOTOR	SI	GALVA 0.8	07/09/09	0.018
1	3621491	SOPORTE TIRADOR CAJON FT	SI	INOFER 1.2	27/06/08	0.058
2	362476	SOPORTE VALV.MINISIT-CONTACTOR	SI	GALVA 1.5	24/09/08	0.122
1	3505991	TAPA TUBOS ENTRADA CORRIENTE	SI	INOFER 0.8	15/09/09	0.740
1	340179	TAPETA IZQ. PETO 750/900	SI	INOFER 1.2	30/11/07	0.135
1	340178	TAPETA DERECHA PETO 750/900	SI	INOFER 1.2	30/11/07	0.135
1	350178	TAPETA LATERAL DERECHA FRONTAL	SI	INOFER 1.2	26/06/07	0.109
1	350179	TAPETA LATERAL IZQUIEDA FRONTAL	SI	INOFER 1.2	26/06/07	0.109
1	362149	TIRADOR CAJON FT (GN2/8-65)	SI	INOX 1.2	19/11/07	0.162
1	330213	TRASERO 800	SI	INOFER 0.8	07/01/09	4.103
2	C5520799	BORNE PHOENIX AZUL UK-10N	NO	PLAS.	10/01/11	0.017
6	C5520801	BORNE PHOENIX GRIS UK-10N	NO	PLAS.	10/01/11	0.017
2	C5520800	BORNE PHOENIX VERDE-AMA.UK-10N	NO	PLAS.	10/01/11	0.017
2	348173PM	CONJUNTO MANDO ELECTRICO	NO	BAQ+ABS	10/12/07	0.114
2	C5123179	CONTACTOR 25A 230V	NO	PLAS.	11/01/11	0.350
1	C6440489	CUBETA GN 2/8-65	NO	INOX	19/11/07	0.555
2	350503P	EJE SUPERIOR PUERTA	NO	FE.ZN	25/05/08	0.013
2	340172P	EMBELLECEDOR MANDO GAS/ELECT.	NO	ABS	10/12/07	0.018
2	6084	IMAN	NO	IMAN - INOX	01/01/01	0.021
2	348173P	MANDO ELECTRICO	NO	BAQ	10/12/07	0.096
4	C6260511	PATA INOX 130-200 (S_F)	NO	INOX	01/01/09	0.320
2	C5120219	PILOTO REDONDO ROJO D.5.5	NO	CU	14/04/09	0.002
1	362406P	PLANCHA CR LISA 795X540	NO	CR 15mm	13/01/09	52.465
2	C5520049	REGLETA MOTOR	NO	CERAM.	28/08/09	0.076



FAMILIA: COCINAS 2008

FECHA: 10/01/11

MODELO: 3626

PESO(Kg): 95.490

DENOMINACION:  
FRYTOP 800X750 ELECTRICO

ESCALA:  
1/10

MATERIAL:  
INOX

CODIGO:  
3626





**Applus®**  
LGAI  
Organismo  
Notificado  
**0370**

**AENOR**  
Organismo  
Notificado  
**0099**

FUNDADA EN 1878  
**MAS BAGA**  
GRANDES COCINAS

**EURAST**

**mag-fin**

TOLERANCIAS GENERALES: ± 0.5 mm

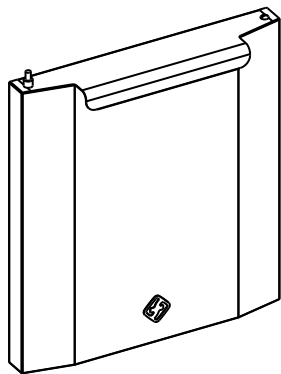

EN LA IMAGEN:  
PUERTA IZQ.  
CAMBIANDO LOS 4 TORNILLOS  
ENTRE SÍ, ES DERECHA.

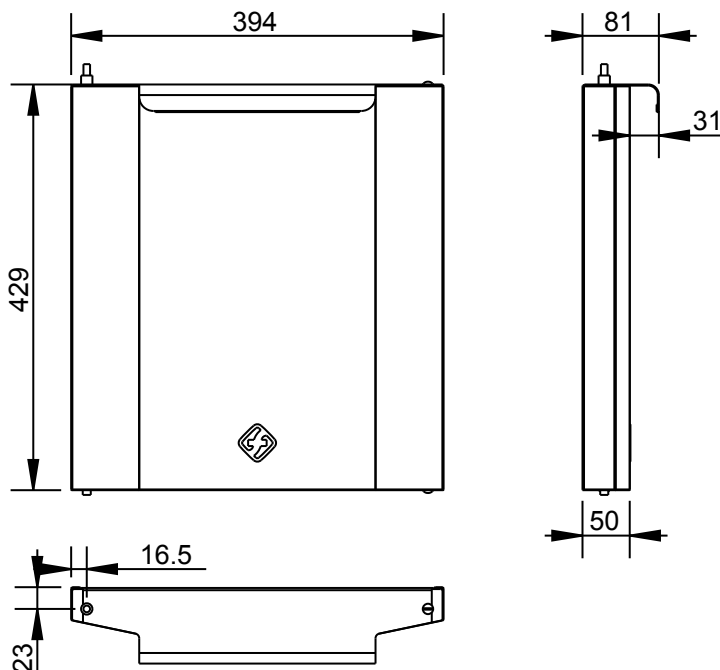

QT.	COD	DESCRIPCION
1	1050	TORNILLO ALLEN M5X12 DIN912
2	1095	TORNILLO M-5X10 TLR INOX
1	350505	PUERTA ARMARIO COCINA
1	350518	CONTRAPUERTA ARMARIO COCINA
1	350503P	EJE SUPERIOR PUERTA

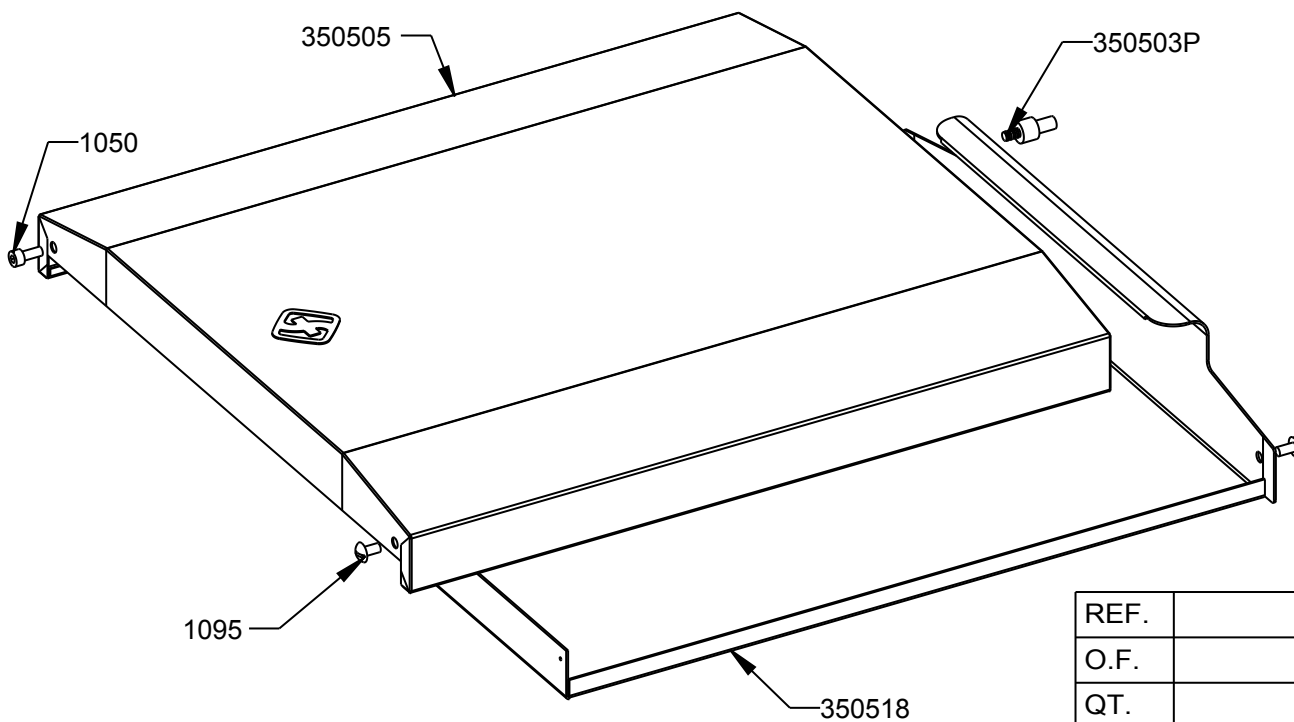

REF.	
O.F.	
QT.	
DEST.	



FAMILIA: COCINAS 2008

FECHA: 26/05/08

MODELO: 3505

PESO(Kg): 3.467

DENOMINACION:  
CONJ. PUERTA COCINA DCHA/IZQ.

ESCALA:  
1/4

MATERIAL:  
INOX

CODIGO:  
350505M