



ISO 9001  
BUREAU VERITAS  
Certification



ISO 14001  
BUREAU VERITAS  
Certification



**Applus®**  
LGA1  
Organismo  
Notificado  
**0370**

**AENOR**  
Organismo  
Notificado  
**0099**

FUNDADA EN 1878  
**MAS BAGA**  
GRANDES COCINAS

**EURAST**

**mac-fin**

TOLERANCIAS GENERALES: ± 0.5 mm

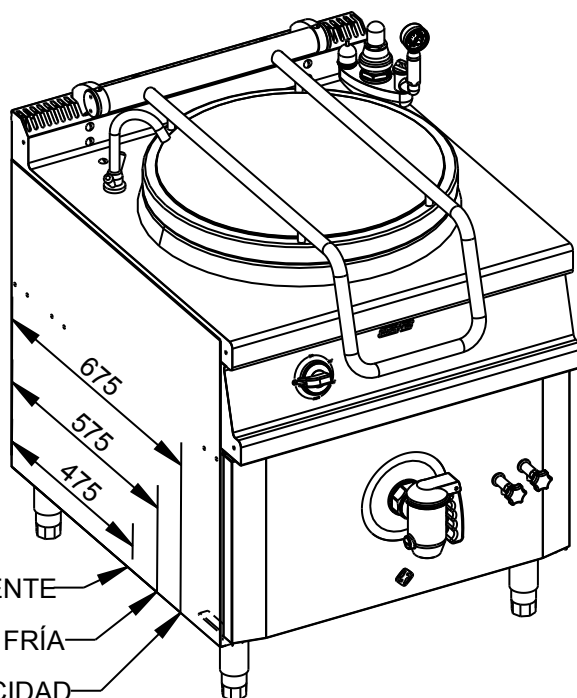
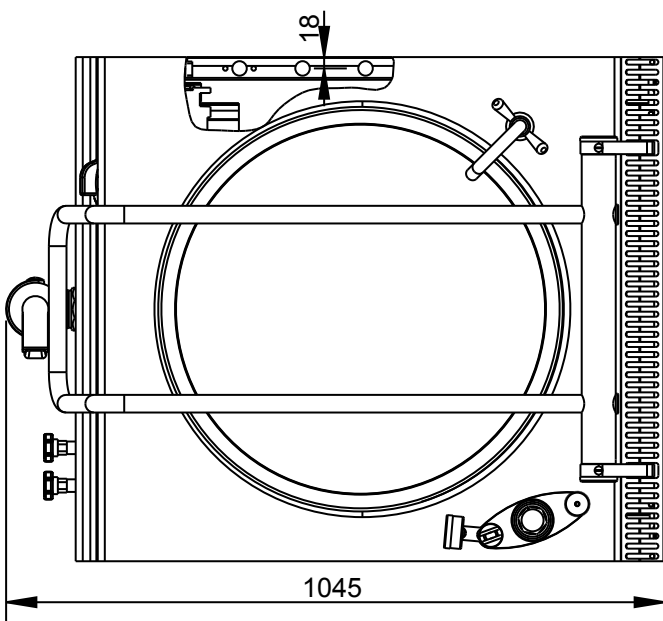
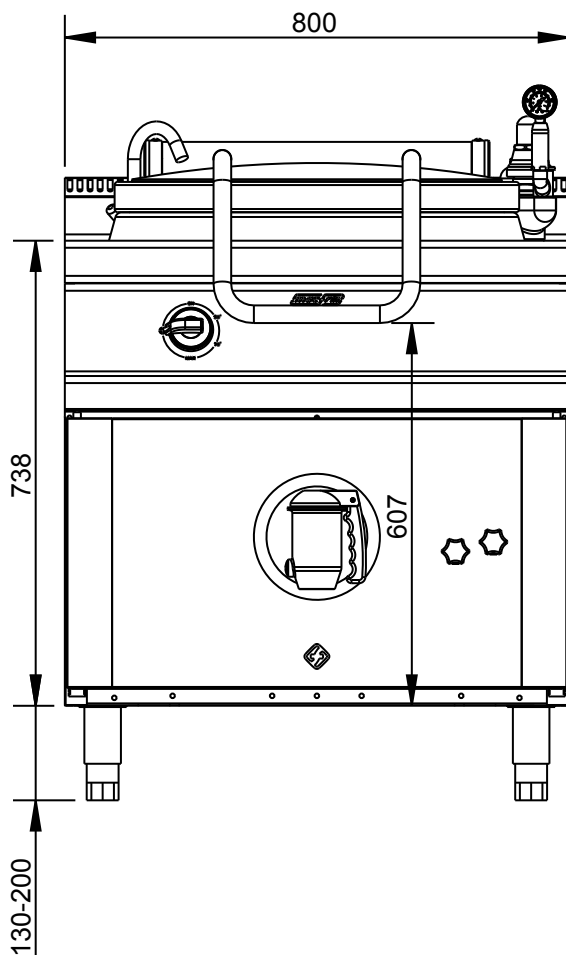
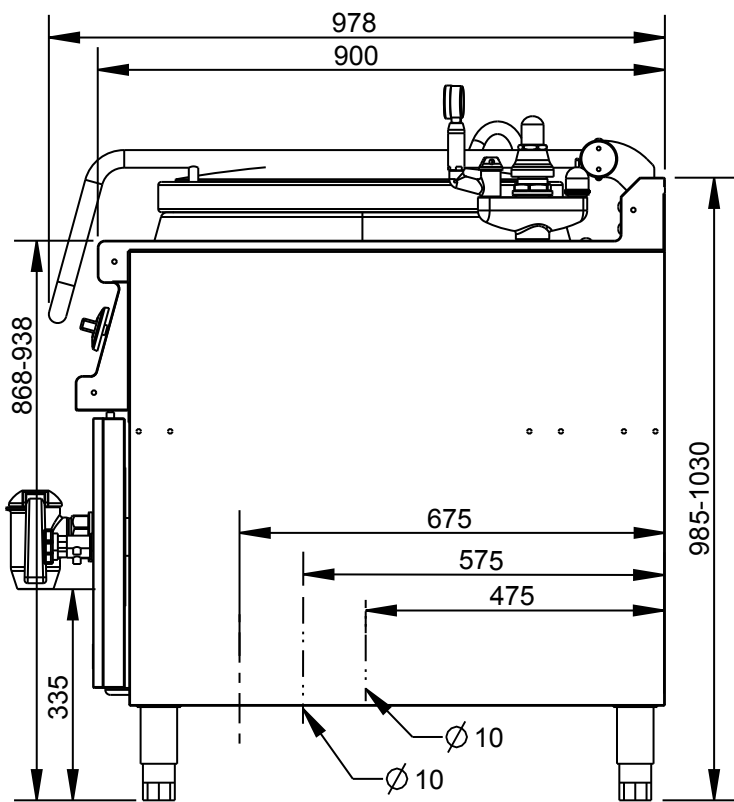

ENTRADA AGUA CALIENTE  
ENTRADA AGUA FRÍA  
ENTRADA ELECTRICIDAD



FAMILIA: COCINAS 2008

FECHA: 17/07/12

MODELO: 4808 HM150E MBM15E

PESO(Kg): 87.999

DENOMINACION:  
MARMITA 150L. ELEC. 800X900

ESCALA:  
1/12

MATERIAL:  
INOX

CODIGO:  
4808



**Applus®**  
LGA1  
Organismo  
Notificado  
**0370**

**AENOR**  
Organismo  
Notificado  
**0099**



TOLERANCIAS GENERALES:  $\pm 0.5$  mm

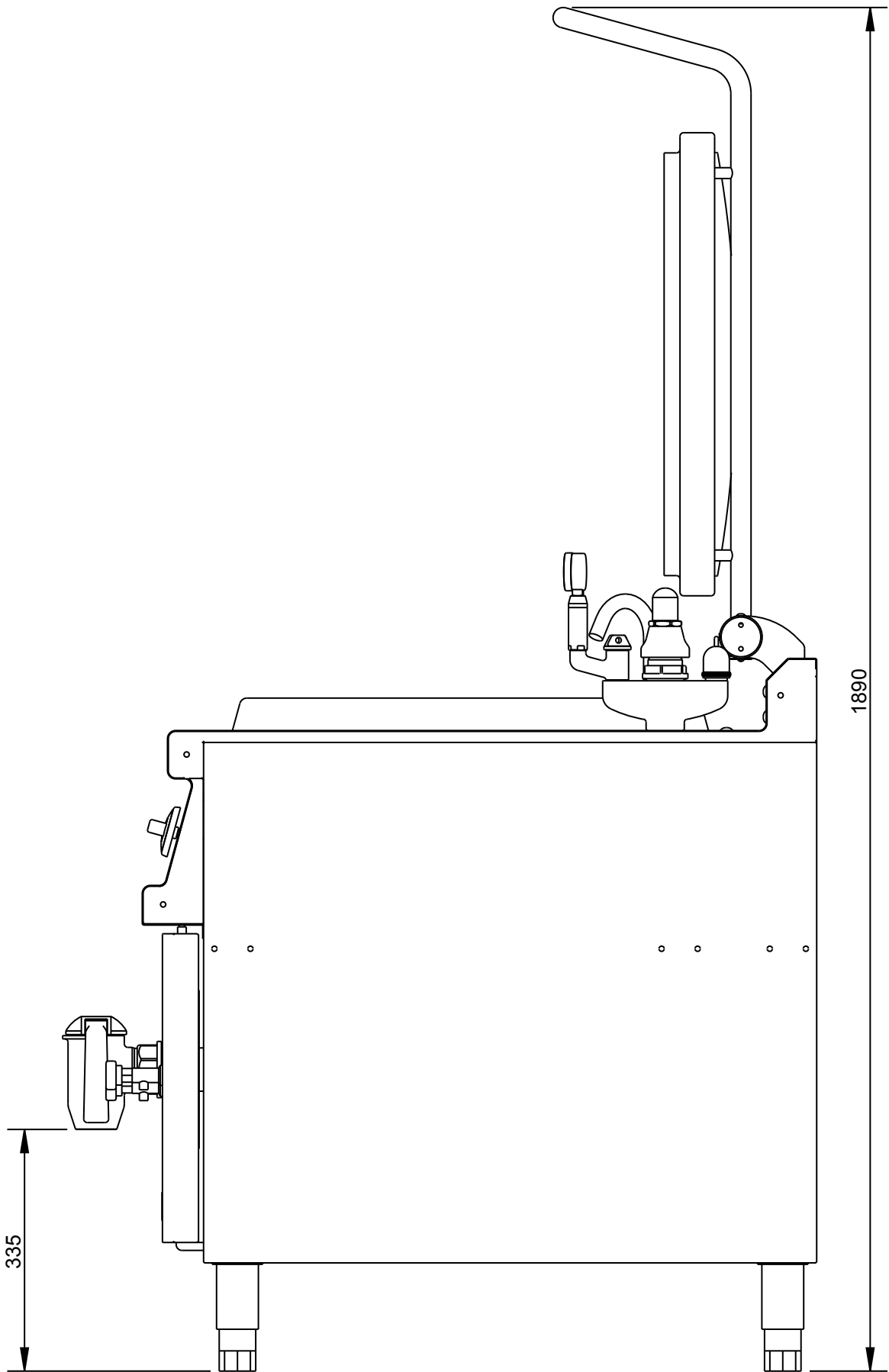

FAMILIA: COCINAS 2008

FECHA: 17/07/12

MODELO: 4808 HM150E MBM15E

PESO(Kg): 87.999

DENOMINACION:  
MARMITA 150L. ELEC. 800X900

ESCALA:  
1/8

MATERIAL:  
INOX

CODIGO:  
4808



**Applus®**  
LGA1  
Organismo  
Notificado  
**0370**

**AENOR**  
Organismo  
Notificado  
**0099**

FUNDADA EN 1878  
**MASBAGA**  
GRANDES COCINAS

**EURAST**

**mag-fin**

TOLERANCIAS GENERALES: ± 0.5 mm

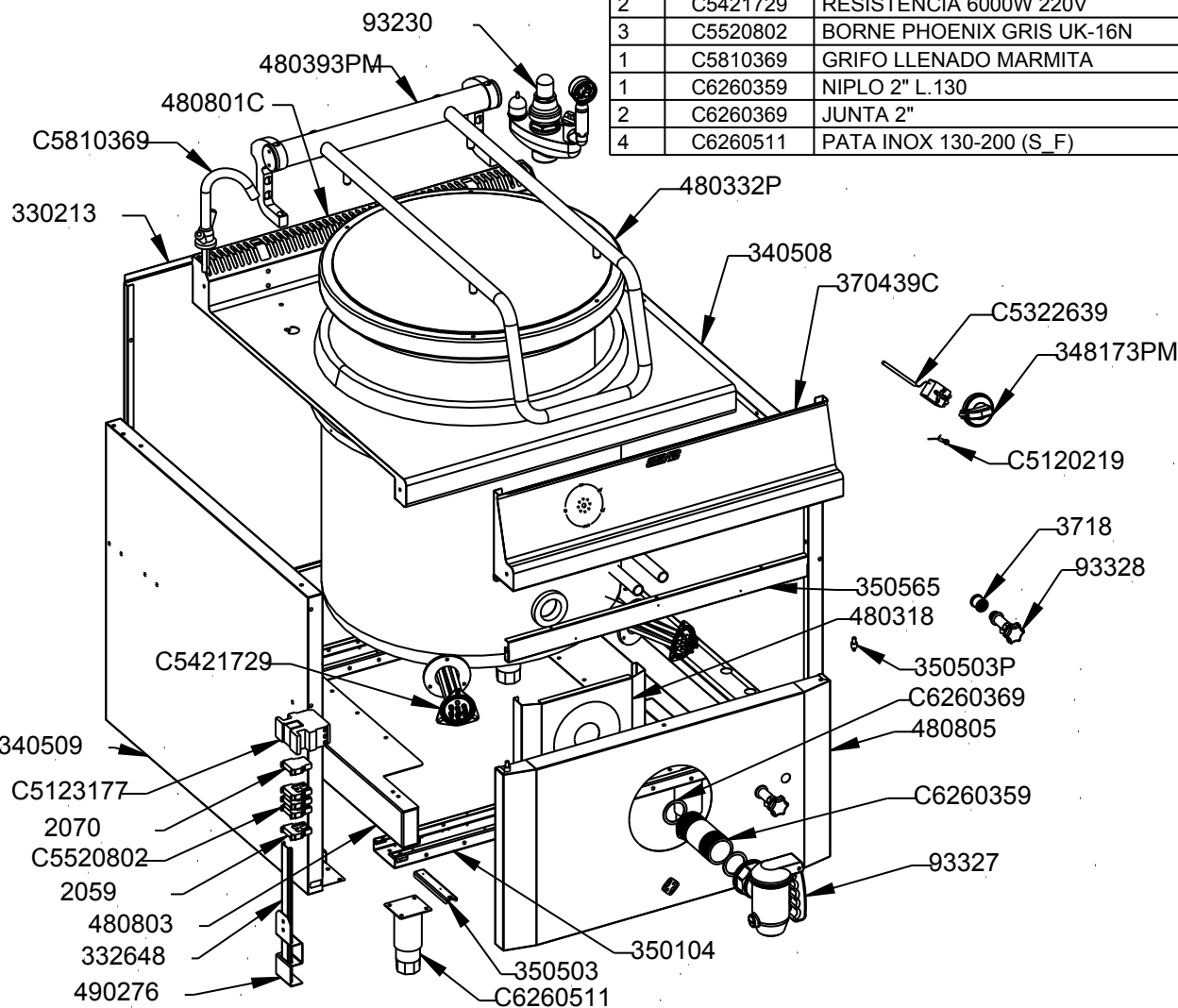
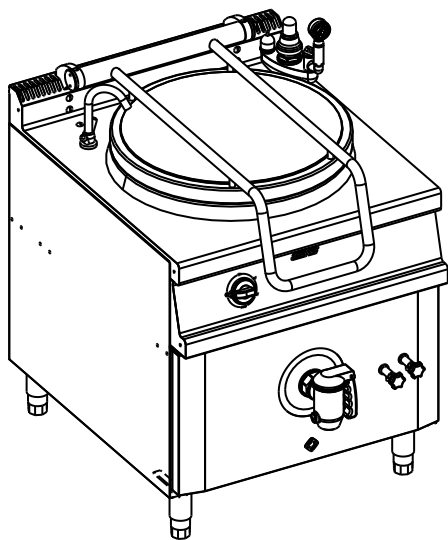

QT	COD	DESCRIPCION
1	2059	BORNE PHOENIX AZUL UK-16BU
1	2070	BORNE PHOENIX TIERRA USLKG16
2	3718	MANGUITO 1/2" H-H
1	93230	GRUPO DE SEGURIDAD 1-1/4"
1	93327	GRIFO DESAGUE MARMITA
2	93328	GRIFO DE AGUJA 1/2"
1	330213	TRASERO 800
1	332648	GUIA CONTACTORES 400
1	340508	LATERAL DERECHO 900
1	340509	LATERAL IZQUIERDO 900
2	350104	OMEGA COCINA 800
2	350503	BISAGRA
1	350565	FRONTAL INFERIOR 800
1	480318	CONTRA FRONTAL MARMITA
2	480803	SOPORTE CUBA MARMITA ELEC.150L IND.
1	480805	FRONT.INF.MARMITA ELEC.150L IND.
1	490276	SOPORTE GUIA 332748-REG.MOTOR
1	348173PM	CONJUNTO MANDO ELECTRICO
2	350503P	EJE SUPERIOR PUERTA
1	370439C	CONJ.FR.MAN.B°M° 800
1	480332P	TAPA MARMITA 900
1	480393PM	ASA MARMITA 900
1	480801C	CUBA MARMITA 150L.ELECT. SOLDADA
1	C5120219	PILOTO REDONDO ROJO D.5.5
1	C5123177	CONTACTOR TRIPOLAR 40A 230V
1	C5322639	TERMOSTATO 0-120°C
2	C5421729	RESISTENCIA 6000W 220V
3	C5520802	BORNE PHOENIX GRIS UK-16N
1	C5810369	GRIFO LLENADO MARMITA
1	C6260359	NIPLO 2" L.130
2	C6260369	JUNTA 2"
4	C6260511	PATA INOX 130-200 (S_F)



FAMILIA: COCINAS 2008

FECHA: 17/07/12

MODELO: 4808 HM150E MBM15E

PESO(Kg): 87.999

DENOMINACION:  
MARMITA 150L. ELEC. 800X900

ESCALA:  
1/15

MATERIAL:  
INOX

CODIGO:  
4808



**Applus®**  
LGA1  
Organismo  
Notificado  
**0370**

**AENOR**  
Organismo  
Notificado  
**0099**



TOLERANCIAS GENERALES: ± 0.5 mm

QT	COD	DESCRIPCION	FAB.	MATERIAL	DATA	PESO
6	TESTA35	ANGULO TESTATINA 35	SÍ	INOX 0.6	29/08/07	0.004
2	TESTA70	ANGULO TESTATINA 70	SÍ	INOX 0.6	29/08/07	0.008
2	TESTA140	ANGULO TESTATINA 140	SÍ	INOX 0.6	29/08/07	0.016
2	TESTA800	ANGULO TESTATINA 800	SÍ	INOX 0.6	19/08/07	0.094
2	350503	BISAGRA	SÍ	INOFER 1.2	20/09/07	0.067
2	481789P	CENTRADOR MUELLE ASA SARTEN	SÍ	INOX D.28x1.5	07/02/11	0.090
1	370439C	CONJ.FR.MAN.B°Mª 800	SÍ	INOX	16/10/09	2.902
1	480318	CONTRA FRONTAL MARMITA	SÍ	INOX 0.8	09/04/09	0.562
1	480805	FRONT.INF.MARMITA ELEC.150L IND.	SÍ	INOX 0.8	17/07/12	2.770
1	350565	FRONTAL INFERIOR 800	SÍ	i441 0.8	15/06/10	0.394
1	370439	FRONTAL MANDOS B°Mª 800	SÍ	INOX 1.2	16/10/09	2.612
1	332648	GUIA CONTACTORES 400	SÍ	GALVA 0.8	30/10/08	0.094
1	340508	LATERAL DERECHO 900	SÍ	INOFER 0.8	20/10/10	5.303
1	380141	LATERAL DERECHO SOBRE 900	SÍ	INOFER 1.2	03/03/09	0.353
1	340509	LATERAL IZQUIERDO 900	SÍ	INOFER 0.8	20/10/10	5.303
1	380140	LATERAL IZQUIERDO SOBRE 900	SÍ	INOFER 1.2	03/03/09	0.353
2	350104	OMEGA COCINA 800	SÍ	GALVA 1.5	13/11/08	1.495
2	480803	SOPORTE CUBA MARMITA ELEC.150L IND.	SÍ	GALVA 1.5	02/07/12	2.338
1	490276	SOPORTE GUIA 332748-REG.MOTOR	SÍ	GALVA 1.5	03/12/10	0.016
1	380778	TAPETA LATERAL DERECHA FRONTAL	SÍ	INOX 1.2	25/02/09	0.121
1	380779	TAPETA LATERAL IZQ. FRONTAL	SÍ	INOX 1.2	26/06/07	0.121
1	330213	TRASERO 800	SÍ	INOFER 0.8	07/01/09	4.103
1	480393PM	ASA MARMITA 900	NO	INOX	17/03/11	8.168
1	480393P	ASA MARMITA-SARTEN 900	NO	INOX	18/11/09	2.490
1	2059	BORNE PHOENIX AZUL UK-16BU	NO	PLAS.	28/08/09	0.023
3	C5520802	BORNE PHOENIX GRIS UK-16N	NO	PLAS.	28/08/09	0.023
1	2070	BORNE PHOENIX TIERRA USLKG16	NO	PLAS.	28/08/09	0.038
1	348173PM	CONJUNTO MANDO ELECTRICO	NO	BAQ+ABS	10/12/07	0.108
1	C5123177	CONTACTOR TRIPOLAR 40A 230V	NO	PLAS.	16/03/11	0.404
1	480801C	CUBA MARMITA 150L.ELECT. SOLDADA	NO	INOX 1.2	14/03/11	33.637
1	480801P	CUBA MARMITA 150L.IND.ELEC.	NO	INOX 1.2	05/06/12	32.718
2	C6260239	CUERPO SOPORTE BISAGRA D.50	NO	FE	22/07/09	0.381
1	480322P	EJE BISAGRA	NO	INOX	25/08/09	1.199
2	350503P	EJE SUPERIOR PUERTA	NO	FE.ZN	25/05/08	0.013
1	340172P	EMBELLECEDOR MANDO GAS/ELECT.	NO	ABS	10/12/07	0.012
2	93328	GRIFO DE AGUJA 1/2"	NO	INOX	14/03/11	0.297
1	93327	GRIFO DESAGUE MARMITA	NO	INOX	01/01/09	2.835
1	C5810369	GRIFO LLENADO MARMITA	NO	CR	01/01/09	0.666
1	93230	GRUPO DE SEGURIDAD 1-1/4"	NO	INOX	15/03/11	2.936
2	C6260369	JUNTA 2"	NO	KLINJERIT	1/1/09	0.004
1	348173P	MANDO ELECTRICO	NO	BAQ	10/12/07	0.096
2	3718	MANGUITO 1/2" H-H	NO	LATON	15/03/11	0.032
1	C6260339	MUELLE DCHO.L.85 D.42.5 E.5	NO	FE	22/07/09	0.154
1	C6260349	MUELLE IZQ.L.85 D.42.5 E.5	NO	FE	22/07/09	0.154
1	C6260359	NIPLO 2" L.130	NO	LATON	03/12/09	0.794
4	C6260511	PATA INOX 130-200 (S_F)	NO	INOX	01/01/09	0.320
1	C5120219	PILOTO REDONDO ROJO D.5.5	NO	CU	14/04/09	0.002
2	C5421729	RESISTENCIA 6000W 220V	NO	INOX	14/03/11	0.825



FAMILIA: COCINAS 2008

DATA:  
17/07/12

MODELO: 4808 HM150E MBM15E

DENOMINACION:  
MARMITA 150L. ELEC. 800X900

ESCALA:  
1/10

MATERIAL:  
INOX

CODIGO:  
4808



**Applus®**  
LGA1  
Organismo  
Notificado  
**0370**

**AENOR**  
Organismo  
Notificado  
**0099**



TOLERANCIAS GENERALES: ± 0.5 mm

2	480340P	SOPORTE BISAGRA	NO	FE 20 CR.	18/11/09	1.331
1	480332P	TAPA MARMITA 900	NO	INOX	15/10/09	5.941
2	480389P	TERMINAL TUBO BISAGRA	NO	FE CR	22/07/09	0.221
1	C5322639	TERMOSTATO 0-120°C	NO	CU	14/04/11	0.078
2	1050	TORNILLO ALLEN M5X12 DIN912	NO	INOX	22/05/09	0.004
6	C1061459	TORNILLO M-6X10 TLR INOX	NO	INOX	20/05/09	0.004
2	C1064343	TORNILLO M-6X40 DIN 963 INOX	NO	INOX	22/07/09	0.011
6	C1063259	TORNILLO M-8X20 TLR INOX	NO	INOX	22/07/09	0.012

	FAMILIA: COCINAS 2008		FECHA: 17/07/12
	MODELO: 4808 HM150E MBM15E		PESO(Kg): 87.999
DENOMINACION: MARMITA 150L. ELEC. 800X900	ESCALA: 1/12	MATERIAL: INOX	CODIGO: 4808



**Applus®**  
LGA1  
Organismo Notificado  
**0370**

**AENOR**  
Organismo Notificado  
**0099**



TOLERANCIAS GENERALES: ± 0.5 mm

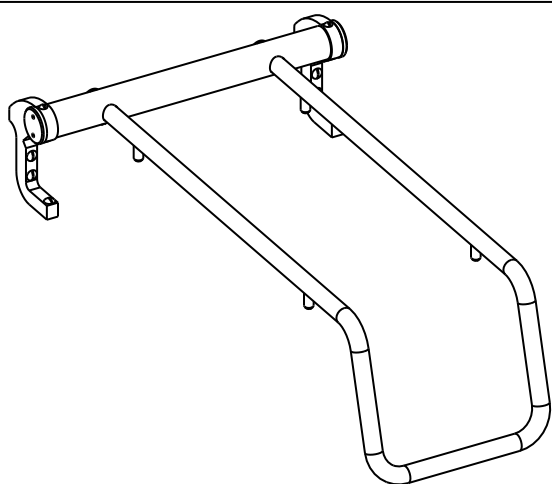

QT	COD	DESCRIPCION
1	480393P	ASA MARMITA-SARTEN 900
2	481789P	CENTRADOR MUELLE ASA SARTEN
2	C6260239	CUERPO SOPORTE BISAGRA D.50
1	480322P	EJE BISAGRA
1	C6260339	MUELLE DCHO.L.85 D.42.5 E.5
1	C6260349	MUELLE IZQ.L.85 D.42.5 E.5
2	480340P	SOPORTE BISAGRA
2	480389P	TERMINAL TUBO BISAGRA
2	1050	TORNILLO ALLEN M5X12 DIN912
6	C1061459	TORNILLO M-6X10 TLR INOX
2	C1064343	TORNILLO M-6X40 DIN 963 INOX
6	C1063259	TORNILLO M-8X20 TLR INOX

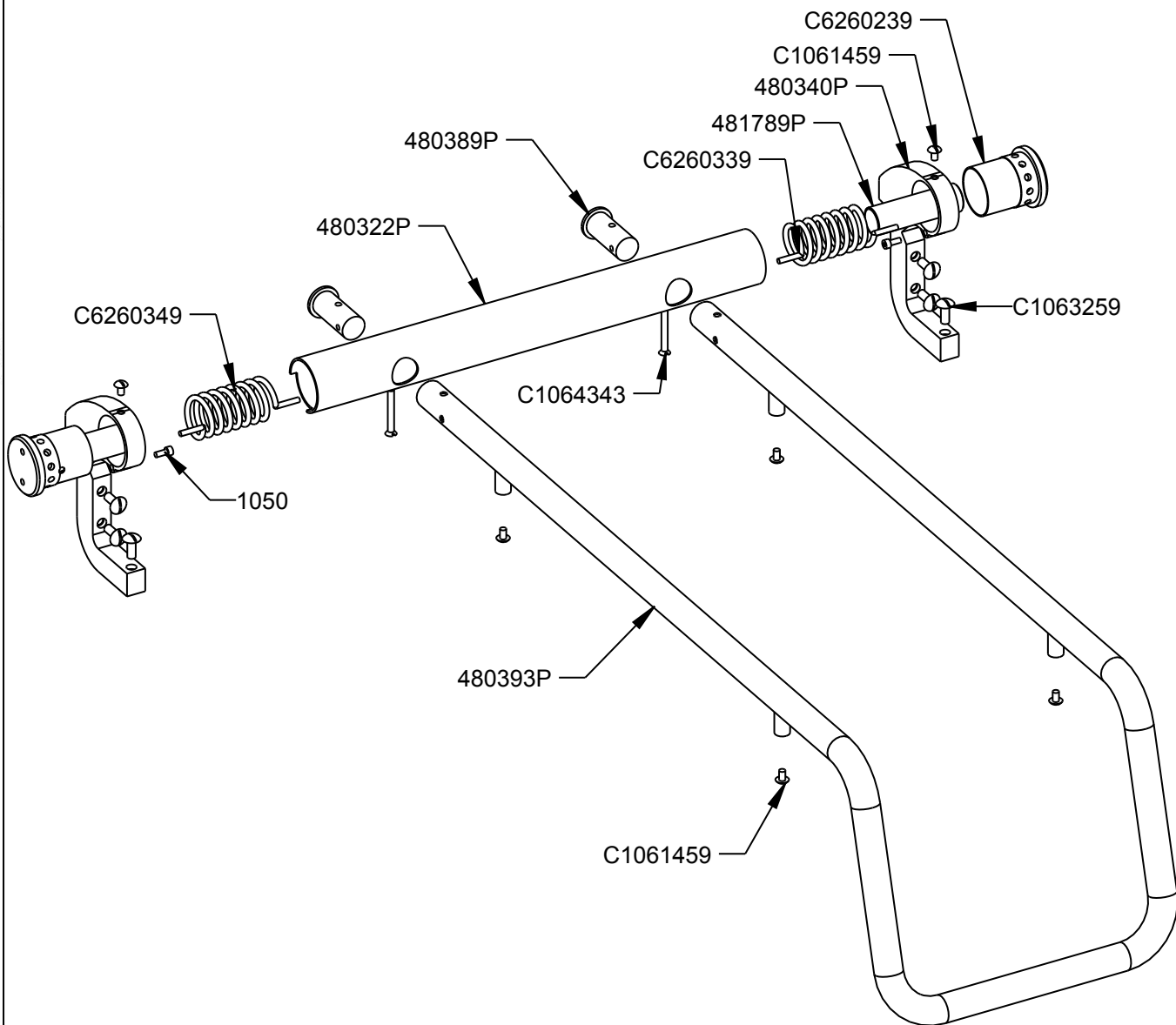

FAMILIA: COCINAS 2008

FECHA: 17/03/11

MODELO: 4803

PESO(Kg): 8.168

DENOMINACION:  
ASA MARMITA 900

ESCALA:  
1/8

MATERIAL:  
INOX

CODIGO:  
480393PM