

C0322 and C0522 Service Parts

This part list contains the service parts for the air cooled, water cooled and remote air cooled C0322, C0522 ice machines.

To avoid costly and time consuming errors, double check the model and voltage before ordering a part.

Note: These abbreviations are used in this list:

- AC = Air Cooled
- WC = Water Cooled
- RC = Remote Cooled
- HGV = Hot Gas Valve
- TXV = Thermostatic Expansion Valve
- Volt = Voltage
- Sol Vlv = Solenoid Valve
- Hdwe = Hardware

Table of Contents

Cabinet	Page 2
Interior Parts	Page 3
Evaporator Compartment	Page 4
Air Cooled Refrigeration System	Page 5
Air Cooled Mechanical & Electrical - C0322	Page 6
Air Cooled Mechanical & Electrical - C0522	Page 7
Water Cooled Refrigeration System	Page 8
C0522 Remote Refrigeration System	Page 9
Electrical & Control Box	Page 10
Compressors	Page 11
Compressor Mounting Hardware	Page 11
Remote Condenser, ERC111, ERC211	Page 12

Scotsman
800-533-6006
www.scotsman-ice.com

C0322 and C0522 Service Parts

Cabinet

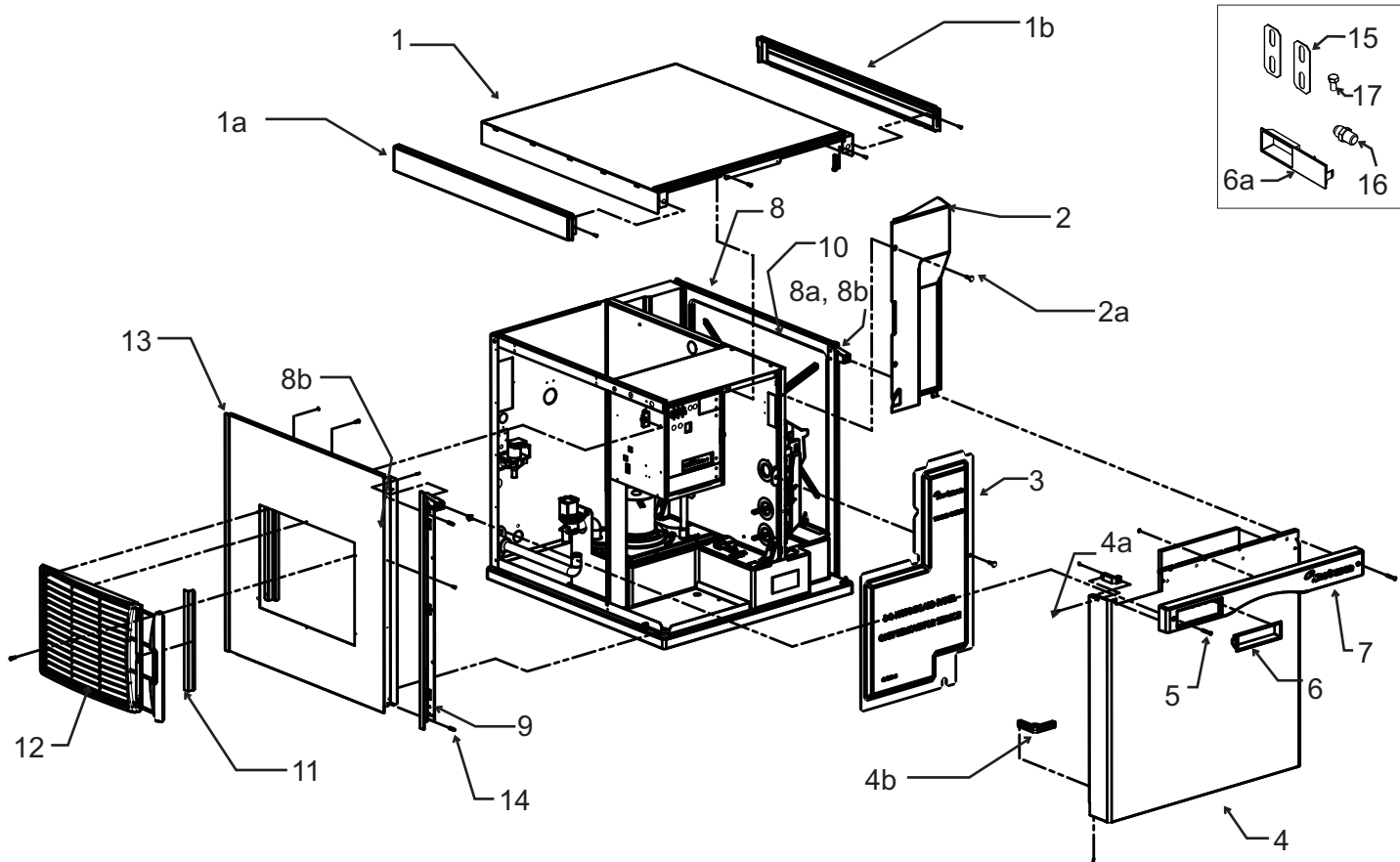

Item Number	Part Number	Description	Item Number	Part Number	Description
1	A38941-021	Top panel, w/trim strips	8b	03-3804-01	Screw receptacle
1a	02-4221-01	Left trim strip	9	02-4067-01	Side panel support for water cooled and remote models
1b	02-4221-02	Right trim strip		02-4067-02	Side panel support for air cooled models
2	02-4240-01	Evaporator cover	10	02-4336-01	Right side panel liner
2a	03-0727-05	Screw	11	02-4212-01	Air filter
3	02-4219-01	Sound shield	12	02-4224-01	Louver panel
4	A38552-021	Front panel assembly, includes trim strip, gussets and labels.	12a	A39222-001	Filter guide
4a	02-4216-01	Top gusset	12b	A39238-001	Louver bracket
4b	02-4217-01	Bottom gusset	13	A38551-021	Left side panel, AC
5	03-1735-03	Screw, front panel		A38551-022	Left side panel WC, RC
6	02-4284-01	Bezel, full window	14	03-1404-12	Screw
6a	02-4284-02	Bezel, partial window	15	A30911-015	Machine straps
7	02-4214-01	Trim strip	16	16-0355-00	Inlet water fitting, flare
8	A38553-021	Right side panel assy	17	03-1405-15	Screw
8a	02-4215-01	Receptacle			

C0322 and C0522 Service Parts

Interior Parts

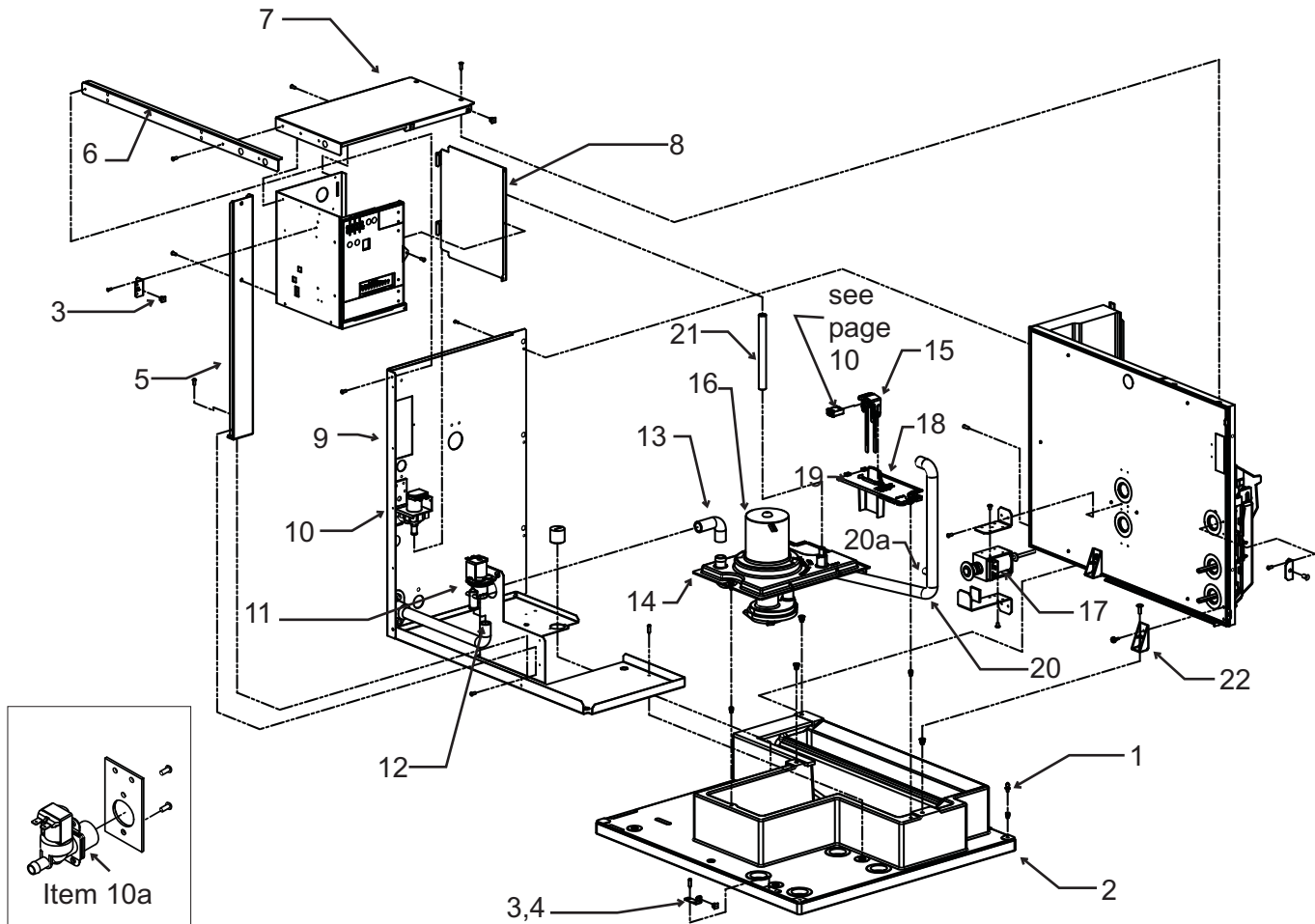

Item Number	Part Number	Description
1	15-0411-00	Strike
2	no number	Base, insulated
3	03-3804-01	Receptacle
4	A38732-001	Side panel mount
5	A38607-001	Strut
6	A38582-001	Brace
7	A38539-002	Control box top
8	A38537-001	Control box side
9	no number	Back panel
10	12-2922-01	Inlet water sol vlv, 115 volt
	12-2922-02	Inlet water sol vlv, 230 volt
	12-2912-01	Water valve rebuild kit
10a	11-0568-02	Inlet water sol vlv, CE mod
11	11-0564-01	Purge valve, 115 volt
	11-0564-02	Purge valve, 230 volt
12	A38861-002	Drain tube
13	A38861-001	Drain hose
14	02-4164-01	Water pump bracket

Item Number	Part Number	Description
15	A39030-021	Water level sensor Harness, see page 10
16	see table	Water pumps

Pumps	115	208-230
C0322, C0522	12-2919-21	12-2919-22

17	see table	Harvest assist solenoid
----	-----------	-------------------------

Hvst. solenoids	115	208-230
C0322, C0522	12-2918-21	12-2918-22

18	02-4165-01	Reservoir cover
19	02-4332-01	Sensor cover
20	02-4154-02	Pump hose, C0522
	02-4154-01	Pump hose, C0322
	11-0515-21	Temp sensor set
21	13-0674-02	Fill hose - order per foot
	15-0821-01	Fill hose, -6 CE models
22	02-4152-01	Gusset

C0322 and C0522 Service Parts

Evaporator Compartment

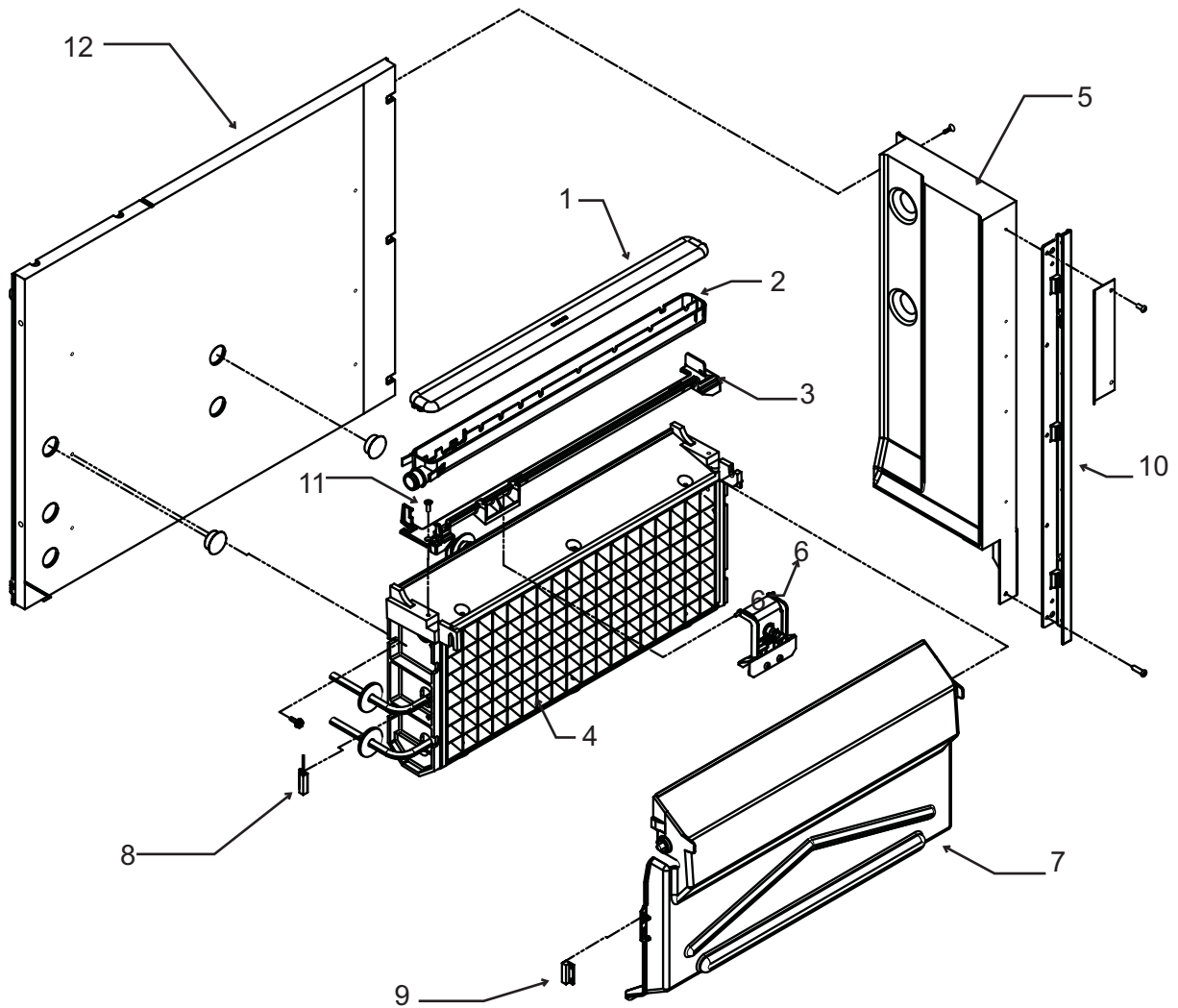

Item Number	Part Number	Description
1	02-4065-01	Water distributor cover
2	02-4064-01	Water distributor
3	02-4205-01	Mounting bracket
4	see table	Evaporator

Item Number	Part Number	Description
7	02-4100-21	Curtain, C0322
	02-4100-22	Curtain, C0522
8	11-0563-01	Curtain switch
9	11-0563-02	Curtain switch magnet
10	02-4067-01	Side panel support
11	03-1418-30	Mounting screw
12	13-0943-01	Gasket tape, order by foot

	small cube	medium cube
C0322	A38626-021	A38626-022
C0522	A38627-021	A38627-022

Note: item 7 includes item 9, shipped loose.

5	A38596-001	Back wall,
6	A39031-021	Ice thickness sensor

C0322 and C0522 Service Parts

Air Cooled Refrigeration System

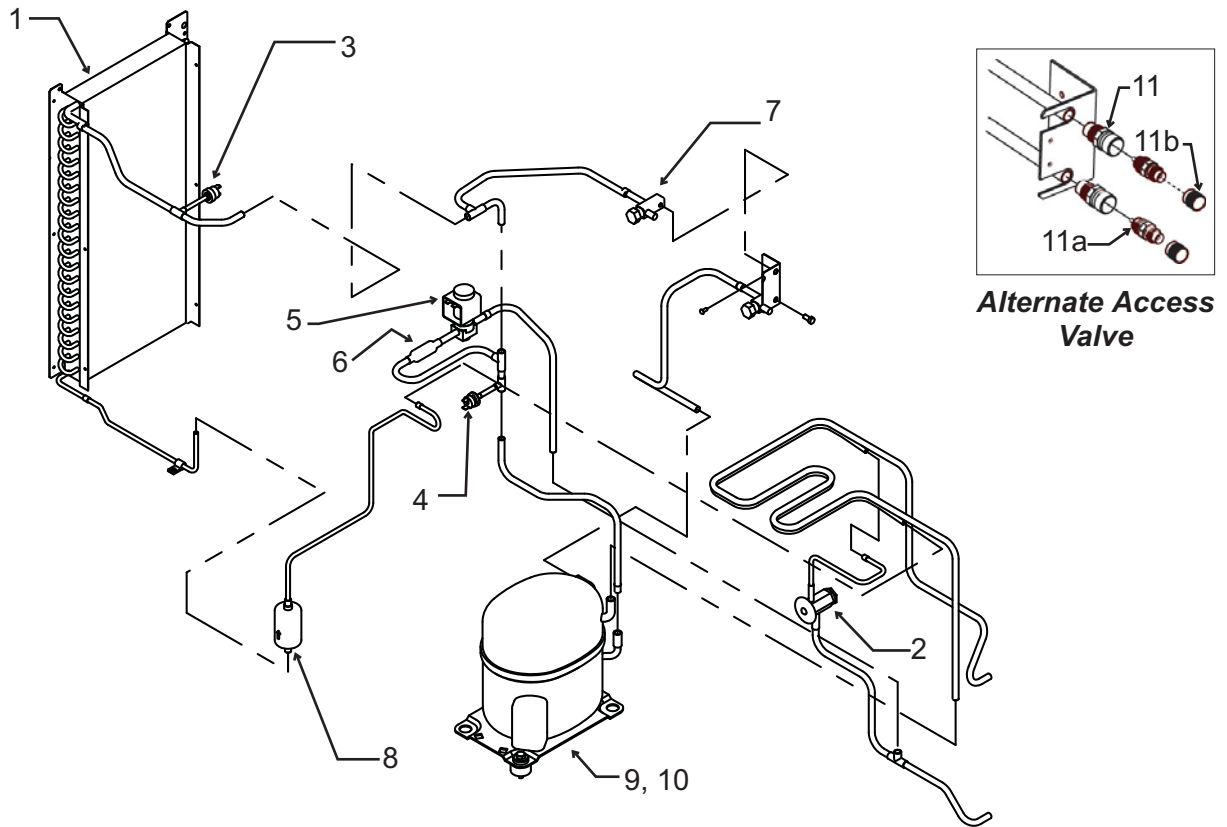

Item Number	Part Number	Description	Item Number	Part Number	Description
1	18-8890-01	Condenser, AC	7	16-0832-20	Access valve
2	16-1117-21	TXV, C0522		16-0832-03	Port cap
	16-1117-23	TXV, C0322		16-0832-02	Stem cap
	02-3792-01	Insulation for Alco TXV	8	02-3319-01	Dryer
3	11-0566-21	Fan cycle pressure sw.	9	see page 12	Compressors
4	11-0501-05	Hi pressure cut out	10	see page 12	Compressor mounting hdw
5	11-0493-02	Hot gas valve w/coil, 115 volt		Alternate Access Valve, use began 4/08	
	12-2719-21	115 volt coil only	11	16-1137-01	Valve body
	11-0493-01	Hot gas valve w/coil, 230 volt	11a	16-1139-01	Core
	12-2719-22	230 volt coil only	11b	16-1140-01	Cap
	12-2733-30	HGV rebuild kit			
6	16-1063-01	Strainer			

C0322 and C0522 Service Parts

Air Cooled Mechanical & Electrical - C0322

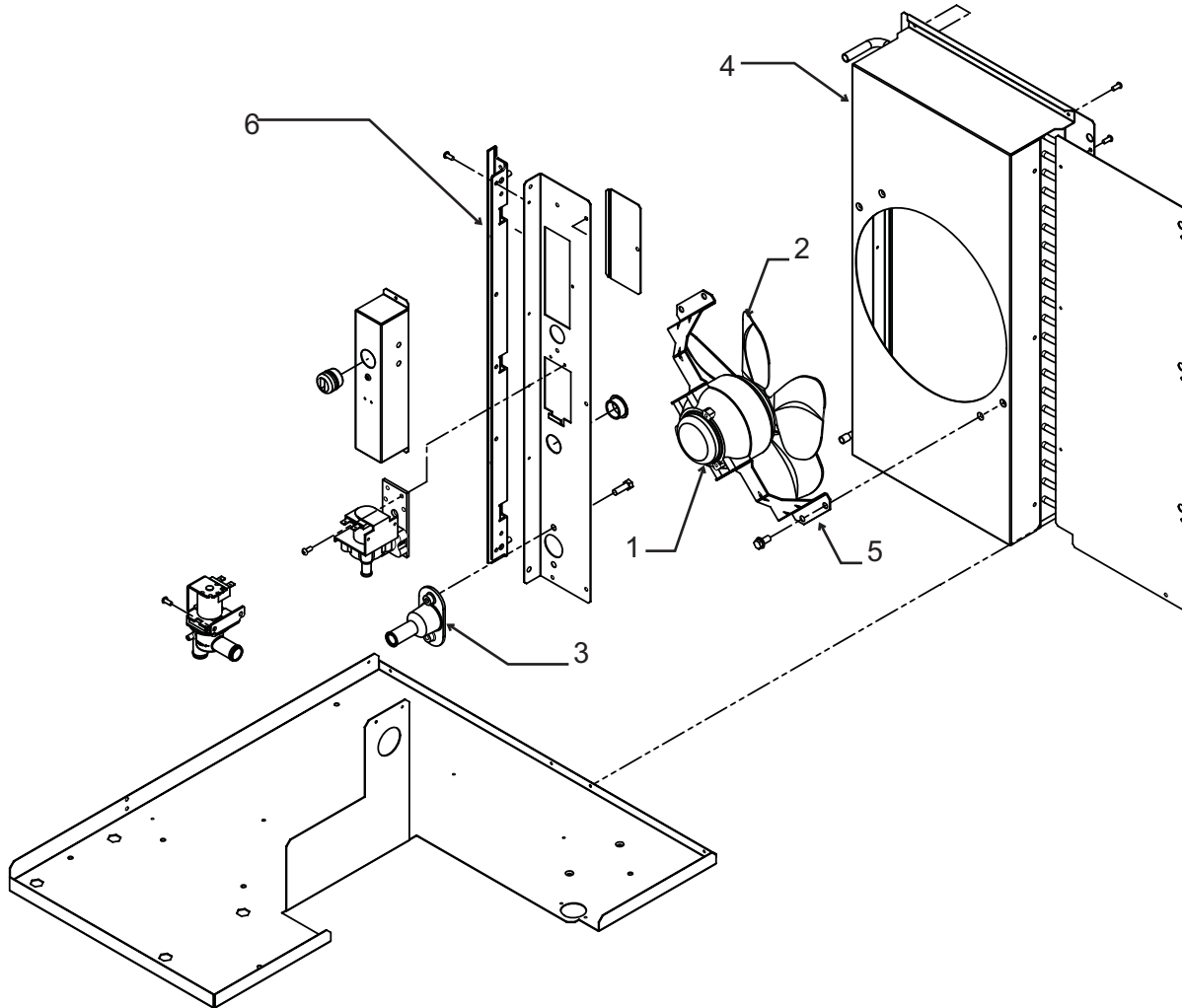

Item Number	Part Number	Description
1	12-1681-23	Fan motor, C0322, 115 volt
	12-1681-04	Fan motor, C0322, 230 volt
2	18-8836-01	Fan blade, C0322
3	02-3692-21	Drain adapter - also for WC and RC
4	A38841-001	Fan shroud, C0322
5	A38480-001	Fan motor bracket, C0322
6	02-4067-02	Side panel support

C0322 and C0522 Service Parts

Air Cooled Mechanical & Electrical - C0522

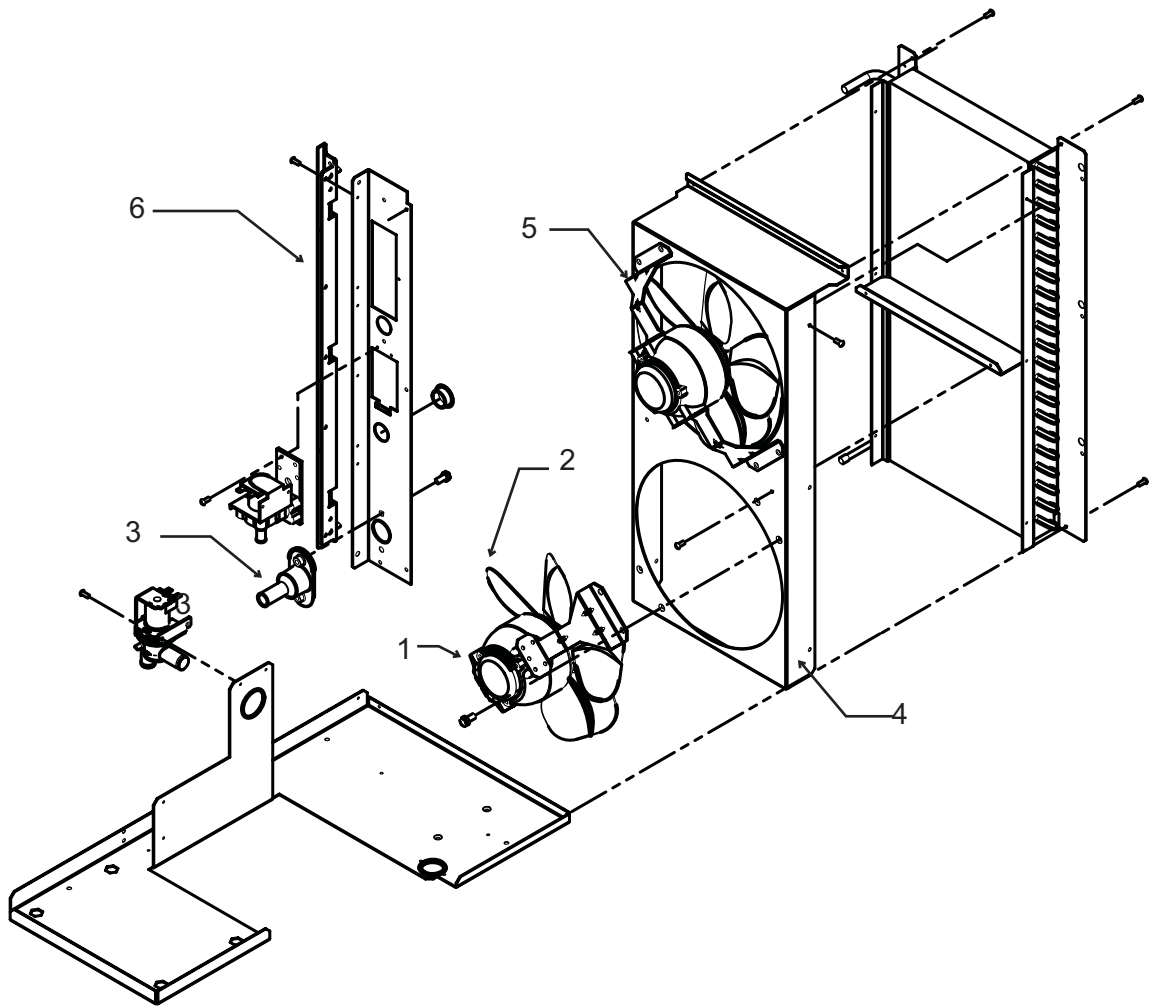

Item Number	Part Number	Description
1	12-1681-23	Fan motor, C0522 115 v
	18-1681-04	Fan motor, C0522 230 volt
2	18-8836-01	Fan blade, C0522
3	02-3692-21	Drain adapter - also for WC and RC
4	A38605-001	Fan shroud - C0522
5	A38480-001	Fan motor bracket, C0522
6	02-4067-02	Side panel support

C0322 and C0522 Service Parts

Water Cooled Refrigeration System

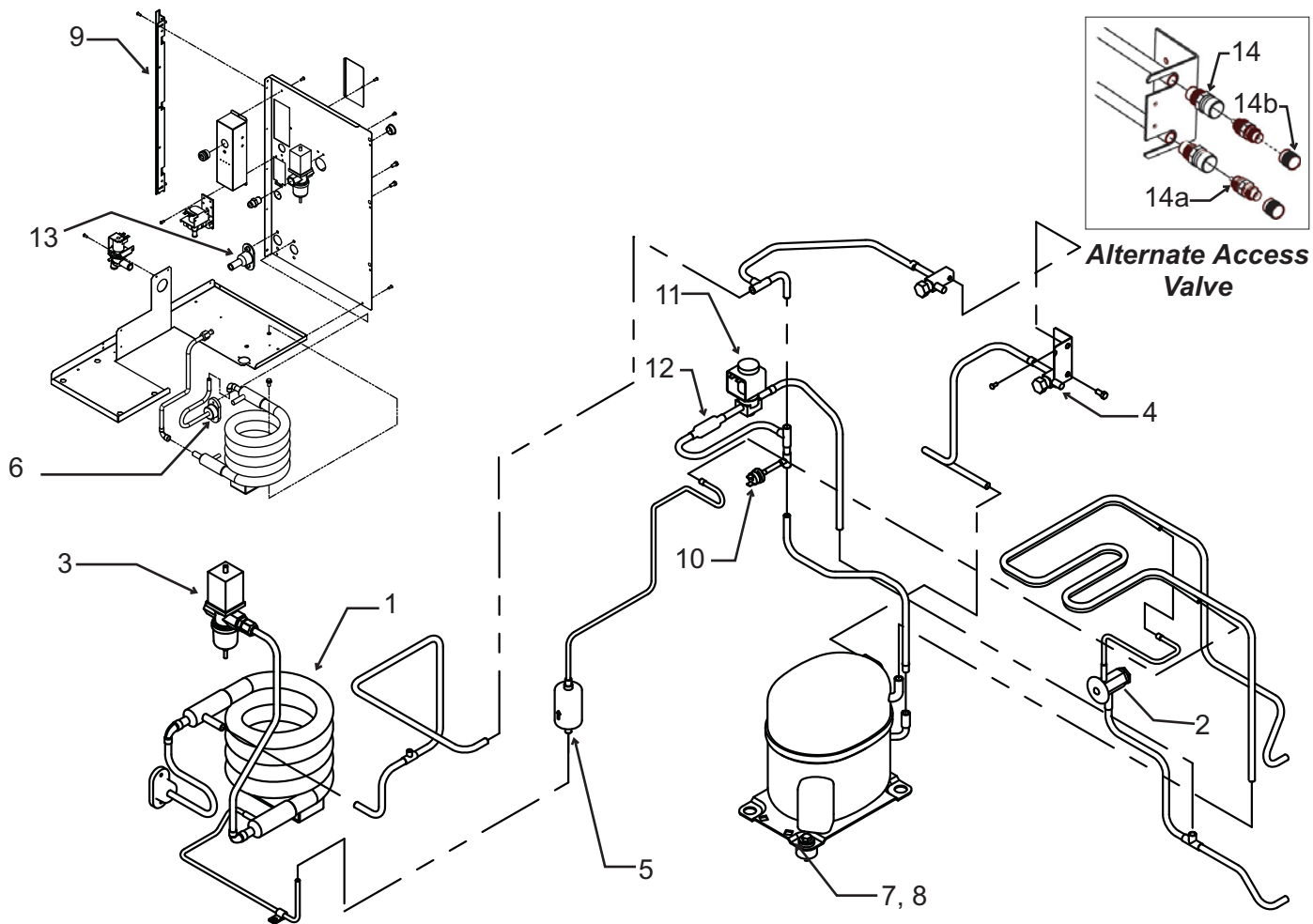

Item Number	Part Number	Description	Item Number	Part Number	Description
1	18-8871-21	Condenser	10	11-0501-21	High pressure cut out
2	16-1117-21	TXV, C0522	11	11-0493-02	Hot gas valve, 115 volt
	16-1117-23	TXV, C0322		12-2719-21	115 volt coil
	02-3792-01	Insulation for Alco TXV		11-0493-01	Hot gas valve & coil, 230 volt
3	11-0478-01	Water regulating valve		12-2719-22	230 volt coil only
4	16-0832-20	Access valve		12-2733-30	HGV rebuild kit
	16-0832-03	Port cap	12	16-1063-01	Strainer
	16-0832-02	Stem cap	13	02-3692-21	Drain adapter
5	02-3319-01	Drier		Alternate Access Valve, use began 4/08	
6	A31828-002	Condenser drain	14	16-1137-01	Valve body
7	see page 12	Compressors	14a	16-1139-01	Core
8	see page 12	Compressor mounting hdw	14b	16-1140-01	Cap
9	02-4067-01	Side panel support			

C0322 and C0522 Service Parts

C0522 Remote Refrigeration System

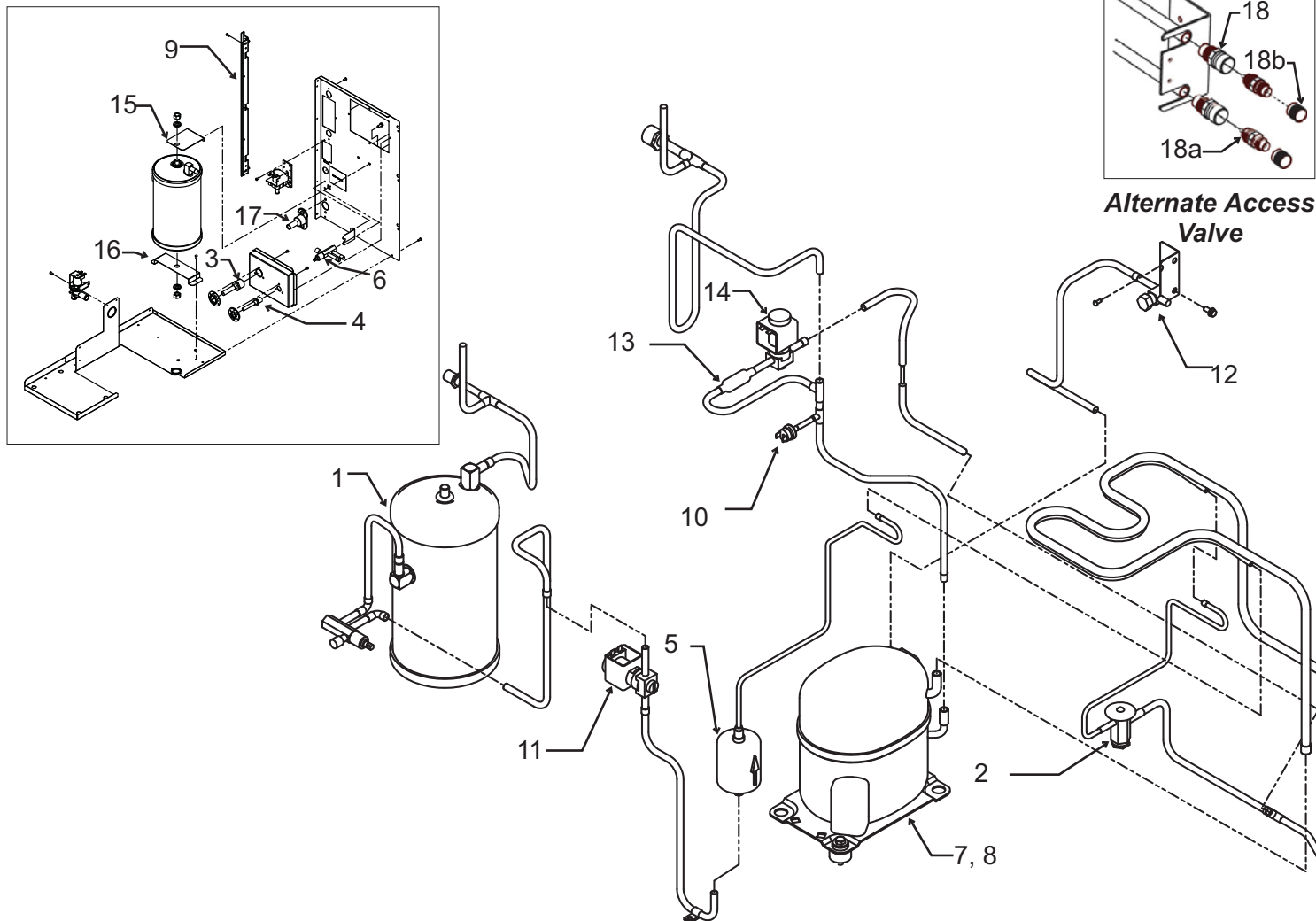

Item Number	Part Number	Description	Item Number	Part Number	Description
1	16-1121-01	Receiver	11	11-0493-02	Liquid line valve or HGV, 115 volt
2	16-1117-21	TXV	12	16-0832-20	Access valve
	02-3792-01	Insulation for Alco TXV		16-0832-03	Port cap
3	16-0850-01	Discharge quick connect		16-0832-02	Stem cap
4	16-0850-03	Liquid quick connect	13	16-1063-01	Strainer
5	02-3319-02	Drier	14	11-0493-02	Hot gas valve
6	16-1030-01	Liquid line access valve	15	A37211-001	Top receiver bracket
7	see page 12	Compressors	16	A37212-001	Bottom receiver bracket
7a	12-2942-01	Crankcase heater	17	02-3692-21	Drain adapter
8	see page 12	Compressor mounting hdw	Alternate Access Valve, use began 4/08		
9	02-4067-01	Side panel support	18	16-1137-01	Valve body
10	11-0501-22	High pressure cut out	18a	16-1139-01	Core
			18b	16-1140-01	Cap

C0322 and C0522 Service Parts

Electrical & Control Box

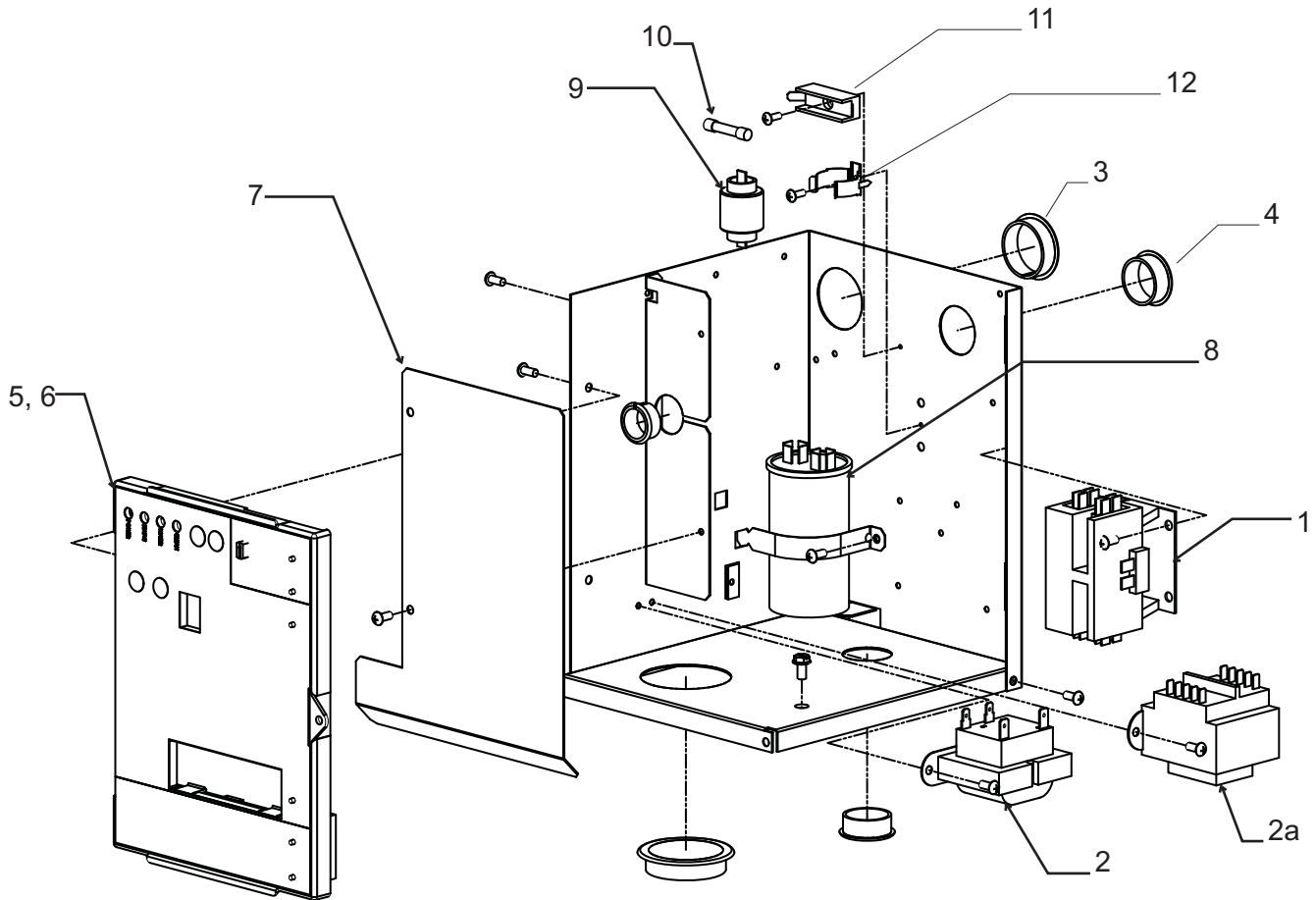

Item Number	Part Number	Description	Item Number	Part Number	Description
1	12-2469-03	Contactor, 115 volt	9	see next page	PTCR -
	12-2469-02	Contactor, 230, single ph	10	12-2686-01	Fuse, 50 Hz only
2	12-2924-01	Transformer, 115 volt	11	12-2687-01	Fuse holder
	12-2924-02	Transformer, 230 volt	12	18-8835-02	Bracket
2a	12-2369-01	Transformer, 50 Hz	Wiring Harnesses (not illustrated)		
3	12-1213-11	Snap bushing	13	12-2931-01	Power harness, A & W
4	12-1213-15	Snap bushing		12-2931-02	Power harness, Remote
5	11-0550-25	Service controller, fits all Prodigy cubers	Power harness connects to J1 on controller		
6	02-4076-01	Control box door	14	12-2932-01	Hi voltage harness, A & W
	02-4189-01	Overlay label		12-2933-01	Hi voltage harness, Rem
7	A39216-001	Barrier		12-2971-01	Hi voltage, 50 Hz A & W
8	see next page	Run capacitor	Hi voltage harness has the 8 pin connector		
			15	12-2928-01	WLS harness

C0322 and C0522 Service Parts

Compressors

Model	Electrical	Compressor	Overload	Run Capacitor	PTCR
C0322-1	115/60/1	18-8897-21	18-8897-23	18-1902-53	18-8835-01
C0322-6	230/50	18-8897-26	18-8897-28	18-1902-57	18-8835-01
C0322-32	208-230/60/1	18-8897-22	18-8897-27	18-1902-57	18-8835-01
C0522-1	115/60/1	18-8921-21	18-8921-23	18-1902-45	18-8835-01
C0522-6	230/50	18-8921-26	18-8774-27	18-1902-52	18-8835-01
C0522-32	208-230/60/1	18-8921-22	18-8774-28	18-1902-52	18-8835-01

Note: Service compressors include run capacitor, overload, PTCR and drier.

Compressor Mounting Hardware

Model	Bolt	Washer	Grommet	Sleeve
C0322	03-1405-20	03-1407-07	18-4700-28	18-0108-41
C0522	03-1405-20	03-1407-07	18-4700-28	18-0108-41

C0322 and C0522 Service Parts

Remote Condenser, ERC111, ERC211

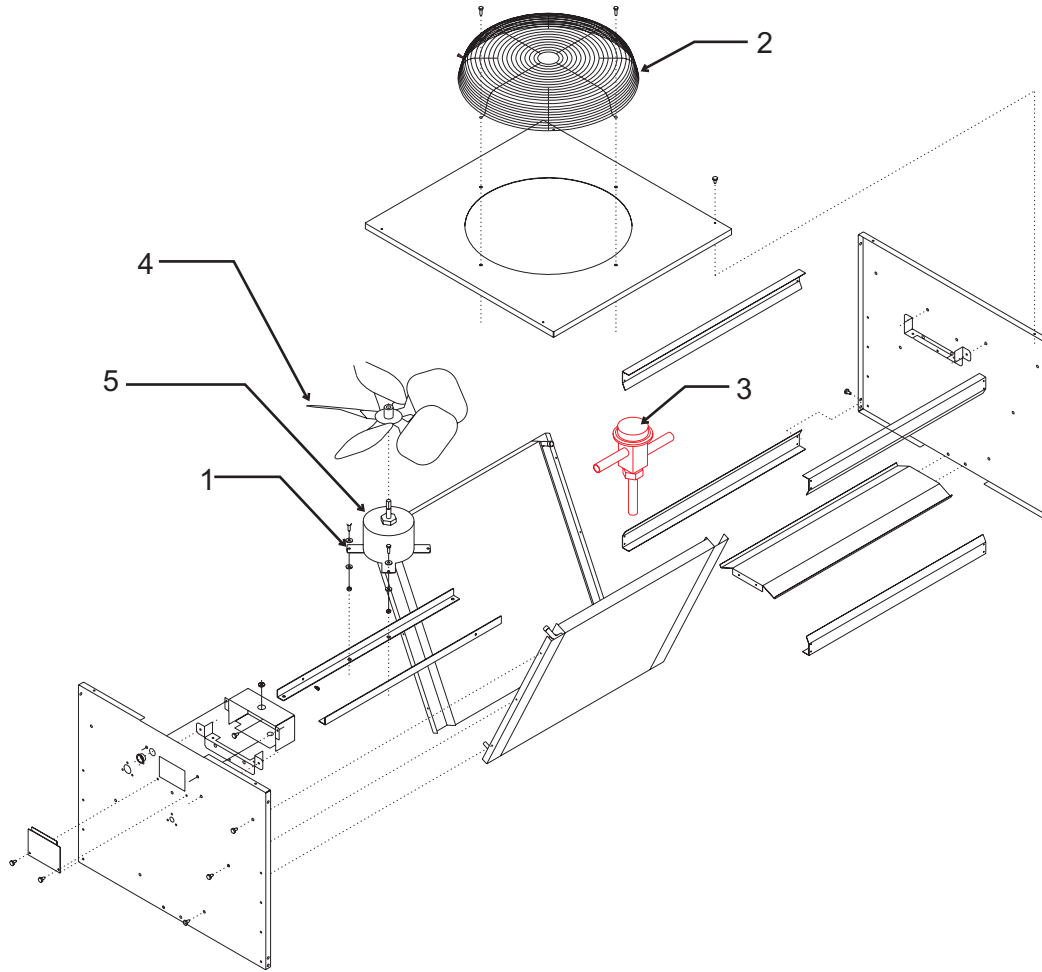

Item Number	Part Number	Description
1	03-1405-08	Screw
2	02-3575-01	Fan guard
3	16-1044-01	Headmaster
4	18-8816-01	Fan blade
5	12-2651-02	Fan motor - 115 volt (ERC111 and ERC211)

Not Shown:

A37169-001	Leg
A37170-001	Leg brace
03-1645-01	Screw for legs
16-0850-01	Quick connect, discharge
16-0850-03	Quick connect, liquid