



ISO 9001
BUREAU VERITAS
Certification



ISO 14001
BUREAU VERITAS
Certification



Applus®
LGA1
Organismo
Notificado
0370

AENOR
Organismo
Notificado
0099

FUNDADA EN 1878
MASBAGA
GRANDES COCINAS

EURAST

mac-fini

TOLERANCIAS GENERALES: ±0.5 mm

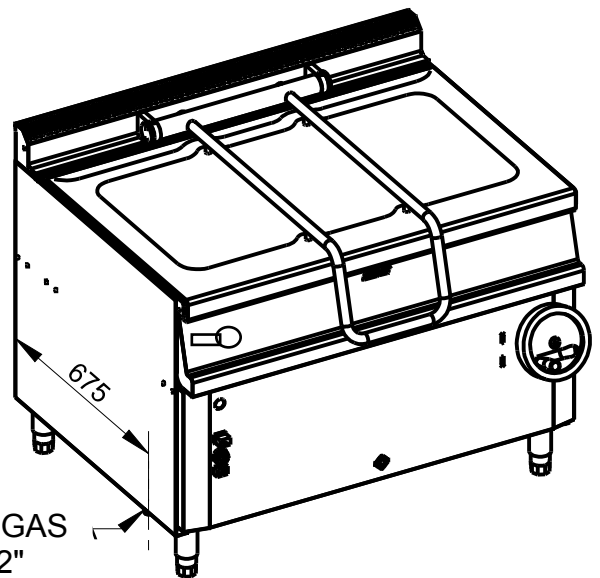
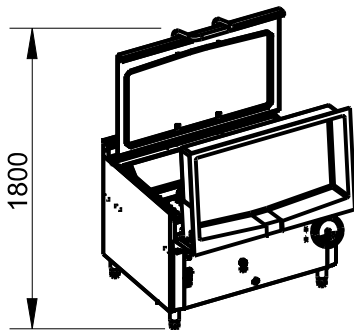
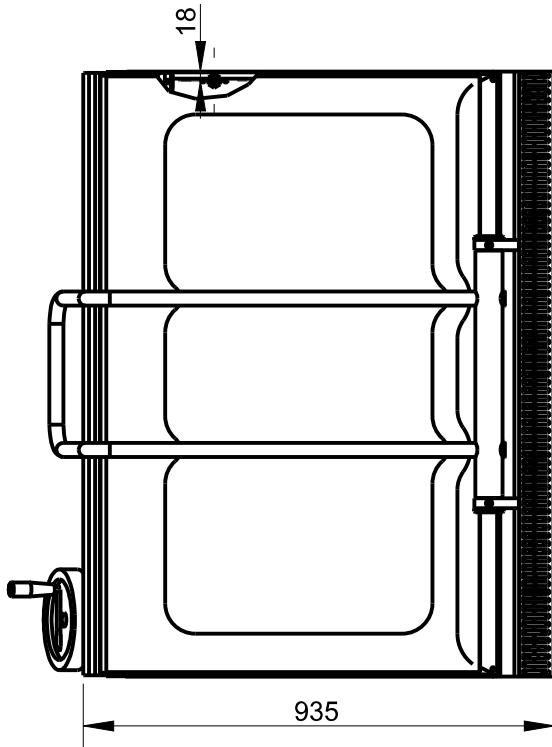
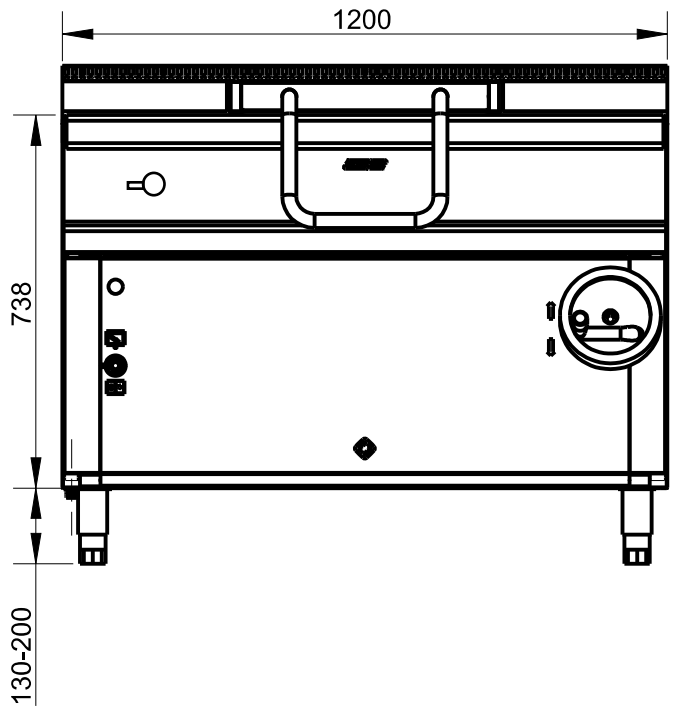
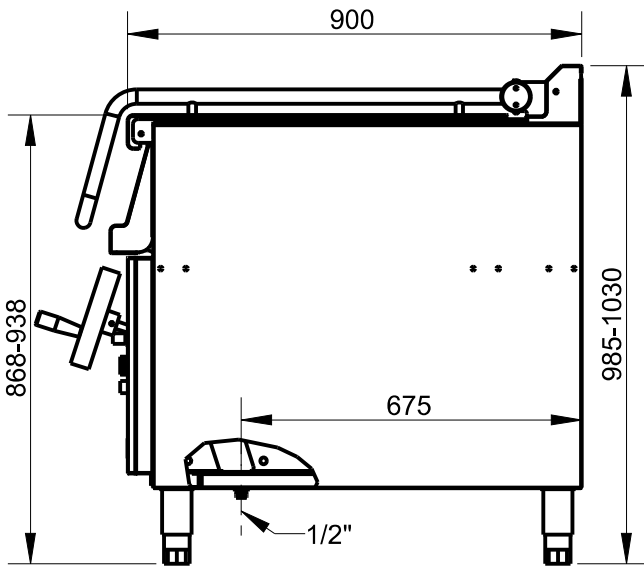

POTENCIA: 32,5 KW



FAMILIA: COCINAS 2008

FECHA: 10/02/11

MODELO: 4817 - HSB120 - ST120G

PESO(Kg): 174.858

DENOMINACION:
SARTEN BASCULANTE 1200x900 GAS

ESCALA:
1/15

MATERIAL:
INOX

CODIGO:
4817



Applus®
LGA1
Organismo
Notificado
0370

AENOR
Organismo
Notificado
0099



TOLERANCIAS GENERALES: ± 0.5 mm

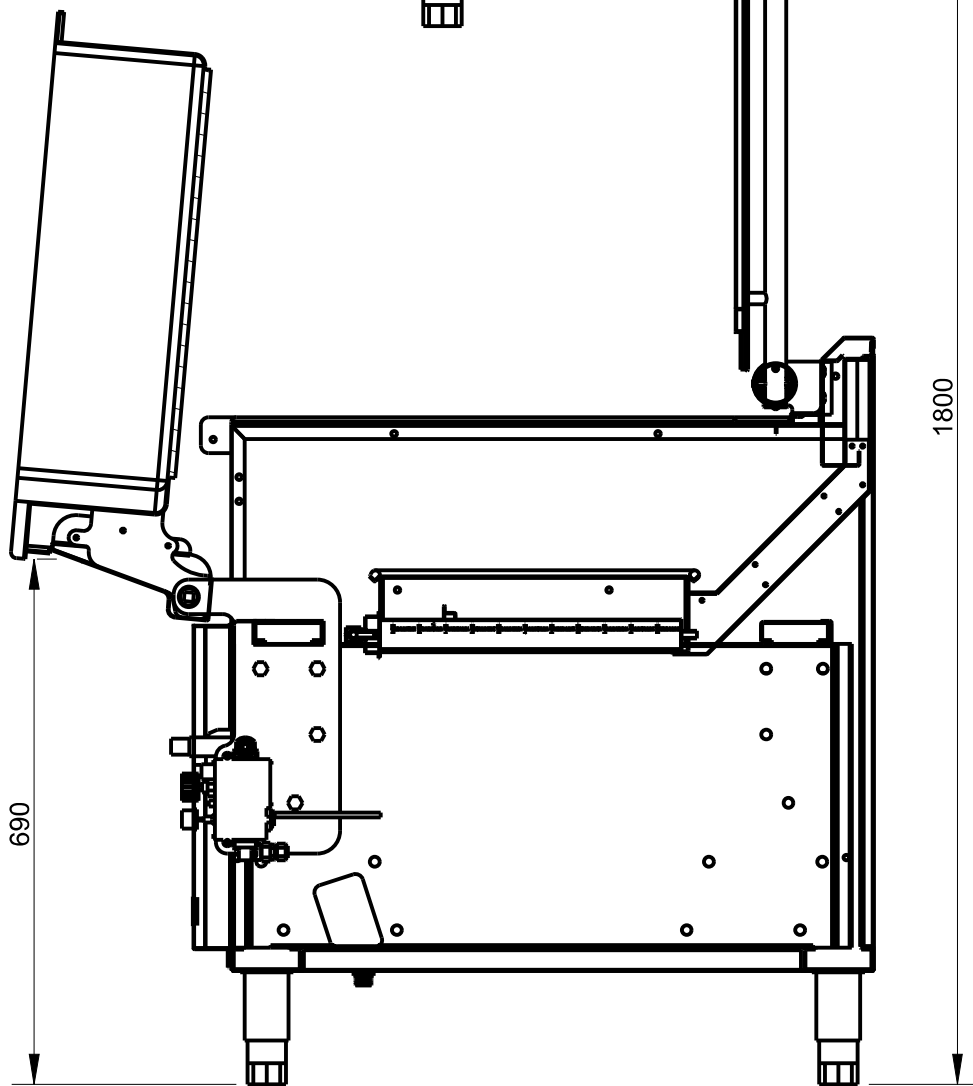
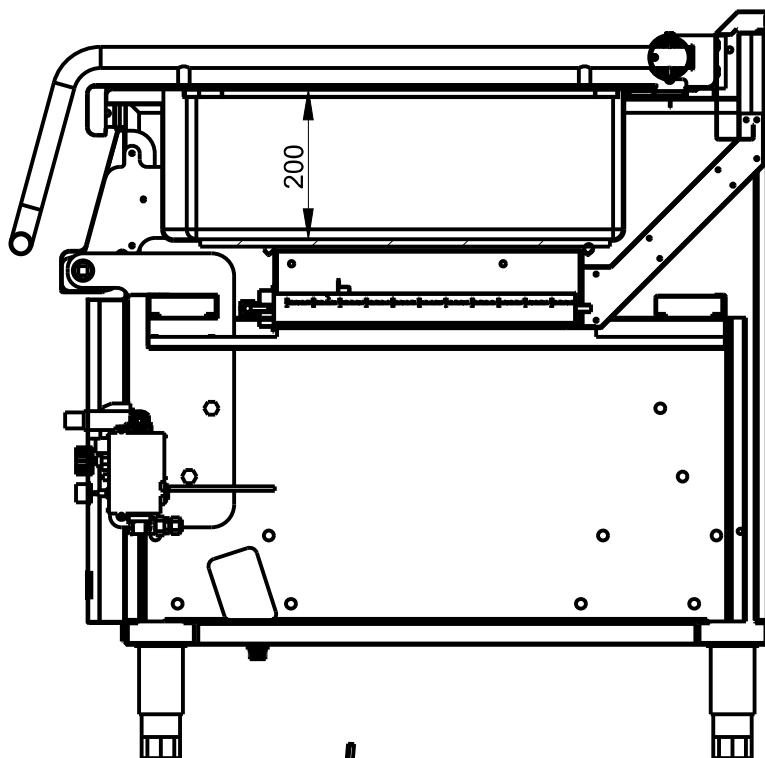

FAMILIA: COCINAS 2008

FECHA: 10/02/11

MODELO: 4817 - HSB120 - ST120G

PESO(Kg): 173.350

DENOMINACION:
SARTEN BASCULANTE 1200x900 GAS

ESCALA:
1/10

MATERIAL:
INOX

CODIGO:
4817



Applus®
LGA1
Organismo
Notificado
0370

AENOR
Organismo
Notificado
0099



TOLERANCIAS GENERALES: ±0.5 mm

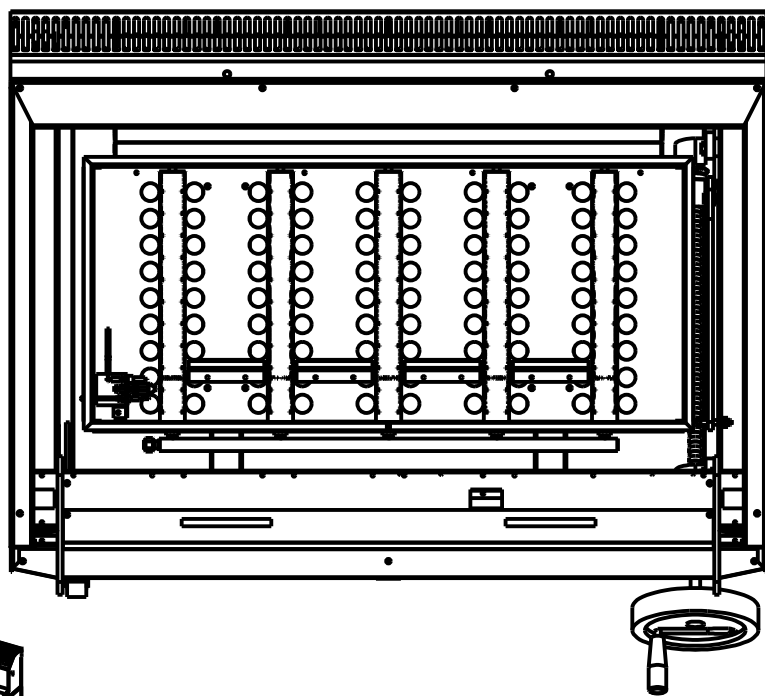
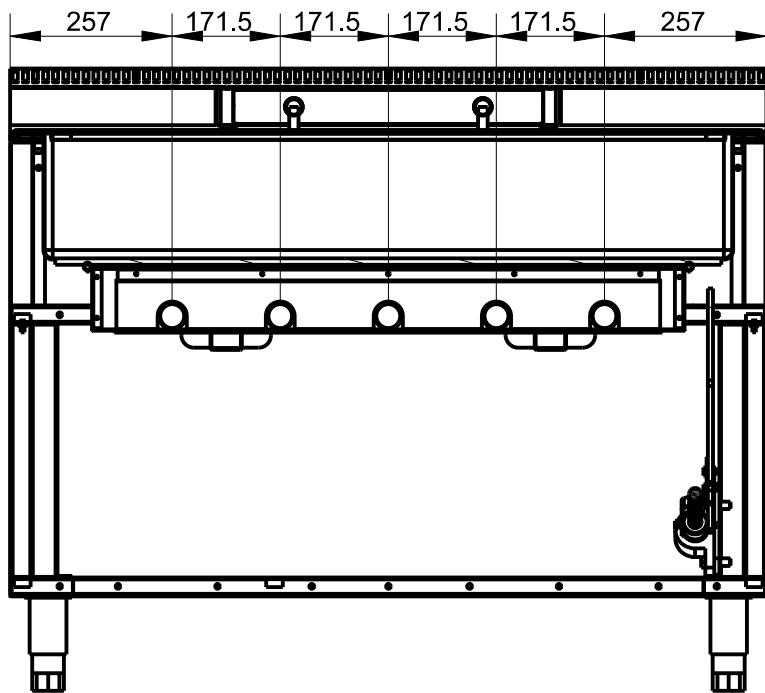
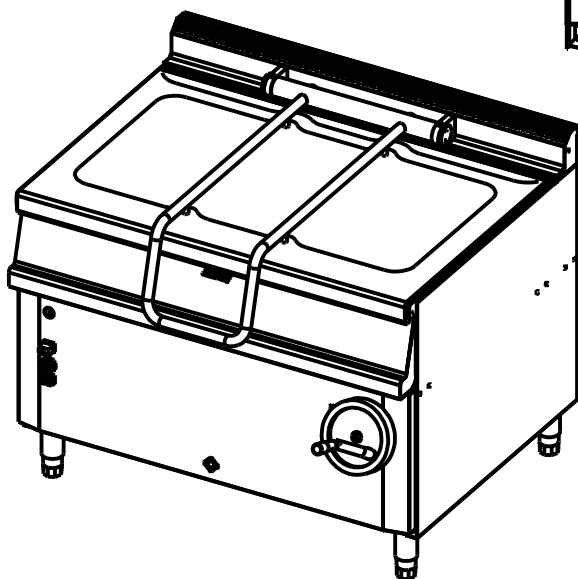

FAMILIA: COCINAS 2008

FECHA: 10/02/11

MODELO: 4817 - HSB120 - ST120G

PESO(Kg): 174.858

DENOMINACION:
SARTEN BASCULANTE 1200x900 GAS

ESCALA:
1/12

MATERIAL:
INOX

CODIGO:
4817



Applus®
LGA1
Organismo
Notificado
0370

AENOR
Organismo
Notificado
0099



TOLERANCIAS GENERALES: ±0.5 mm

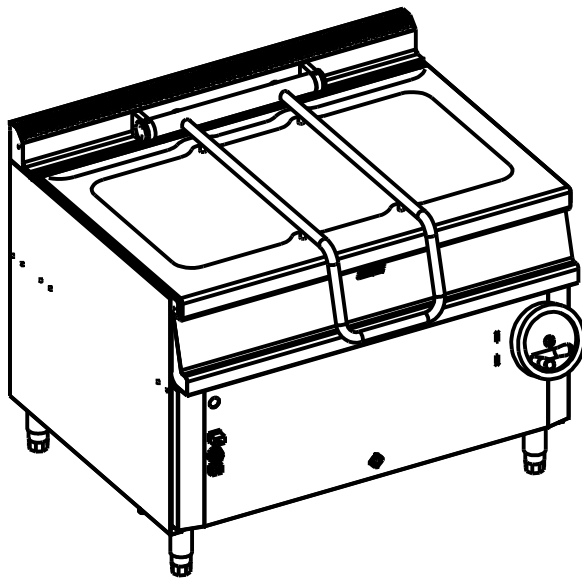

QT	COD	DESCRIPCION
1	3242	TUERCA LATON 1/2"
1	3747	PIEZO ELECTRICO SIT
1	3781	TUERCA M16X1.5 D.10
1	3782	BICONO D.10 LATON
1	330113	TRASERO 1200X600
1	340508	LATERAL DERECHO 900
1	340509	LATERAL IZQUIERDO 900
2	350204	OMEGA COCINA 1200
1	481275	REFUERZO ASA SARTEN 800
1	481705	FRONTAL INFERIOR SARTEN 1200
1	3103M	VALVULA SIT COMPLETA
1	481289P	MACHON D.10 - 1/2" - M16X1.5
1	481293PM	CONJ. ASA SARTEN 900
1	481701M	CONJUNTO CUBA MONTADA 1200x900
1	481716M	DEFLECTOR MONTADO SARTEN 1200
1	481722C	CONJUNTO PETO SARTEN 1200
1	481725M	ARMAZON SARTEN 1200x900
1	481732C	CONJ. TAPA SARTEN 1200X900
1	481749C	CANAL ENCIMERA SARTEN 1200
4	C6260511	PATA INOX 130-200 (S_F)
1	C6262619	VOLANTE MACIZO PLEGABLE D.200
1	T06045	TUBO AL D.6 L.450
1	T10030	TUBO AL D.10 L.300

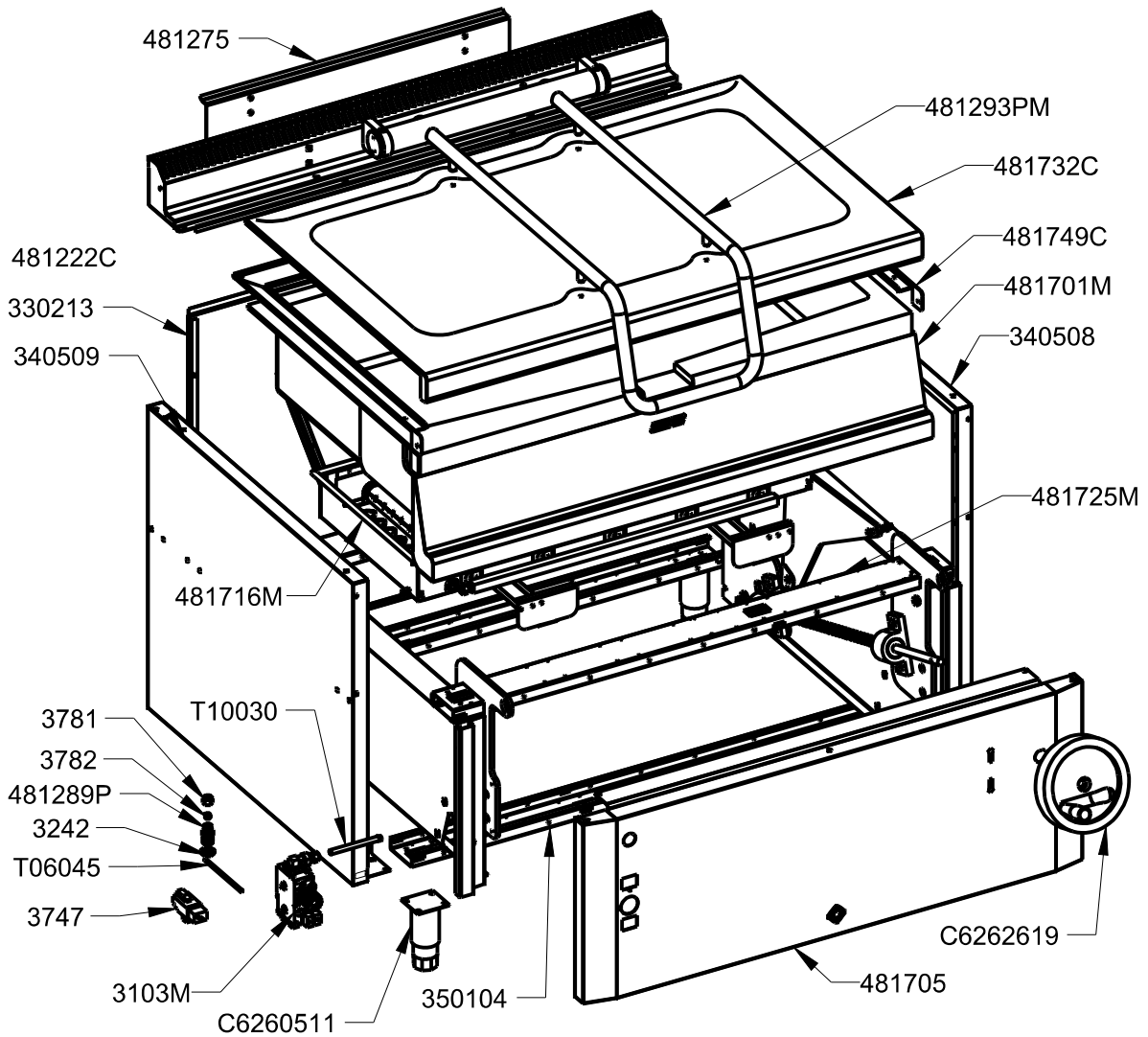

FAMILIA: COCINAS 2008

FECHA: 10/02/11

MODELO: 4817 - HSB120 - ST120G

PESO(Kg): 174.858

DENOMINACION:
SARTEN BASCULANTE 1200x900 GAS

ESCALA:
1/15

MATERIAL:
INOX

CODIGO:
4817



Applus®
LGA1
Organismo
Notificado
0370

AENOR
Organismo
Notificado
0099



TOLERANCIAS GENERALES: ±0.5 mm

QT	COD	DESCRIPCION	FAB.	MATERIAL	DATA	PESO
4	300388	CORRELLAMAS	SÍ	INOFER 0.8	05/02/09	0.106
1	300399	TAPA 20X20 C/AGUJERO D.12	SÍ	FE 1.2	02/09/08	0.003
1	301399	TAPA 20X20	SÍ	FE 1.2	02/09/08	0.004
1	330113	TRASERO 1200X600	SÍ	INOFER 0.8	10/01/08	6.214
1	340178	TAPETA DERECHA PETO 750/900	SÍ	INOFER 1.2	30/11/07	0.135
1	340179	TAPETA IZQ. PETO 750/900	SÍ	INOFER 1.2	30/11/07	0.135
1	340508	LATERAL DERECHO 900	SÍ	INOFER 0.8	20/10/10	5.303
1	340509	LATERAL IZQUIERDO 900	SÍ	INOFER 0.8	20/10/10	5.303
4	350204	OMEGA COCINA 1200	SÍ	GALVA 1.5	17/02/09	2.249
1	481275	REFUERZO ASA SARTEN 800	SÍ	GALVA 1.5	03/02/11	1.675
1	481276	SOPORTE BIELA SARTEN B.	SÍ	INOX 2	04/02/11	0.099
2	481278	TAPETA LATERAL DEFLECTOR	SÍ	GALVA 0.8	22/04/09	0.101
1	481705	FRONTAL INFERIOR SARTEN 1200	SÍ	INOX 0.8	23/04/09	4.626
1	481716	DEFLECTOR SARTEN 1200	SÍ	INOFER 1.2	22/04/09	5.334
1	481722	PETO SOBRE SARTEN 1200	SÍ	INOX 1.2	10/02/11	2.407
2	481725	LATERAL INTERIOR SARTEN 900	SÍ	GALVA 1.5	08/06/09	5.340
1	481726	BURL.CERAM.SARTEN 1200x900-C6580	SÍ	FIBRA	10/02/11	0.311
1	481732	TAPA SARTEN 1200x900	SÍ	INOX 1.2	10/02/11	9.558
1	481739	FRONTAL MANDOS SARTEN 1200	SÍ	INOX 1.2	21/10/10	3.554
1	481740	CANAL IZQ.SARTEN	SÍ	INOX 2	20/04/09	0.558
1	481741	CANAL DCHA.SARTEN	SÍ	INOX 2	20/04/09	0.558
2	481748	OMEGA FIJACIÓN DEFLECTOR	SÍ	GALVA 1.5	07/02/11	1.202
1	481749	CANAL SARTEN 1200	SÍ	INOX 2	20/04/09	1.584
1	481752	SALIDA VAHOS SARTEN 1200	SÍ	GALVA 0.8	22/04/09	5.414
1	481778	TAPETA LATERAL DERECHA FRONTAL	SÍ	INOFER 1.2	20/04/09	0.134
1	481779	TAPETA LATERAL IZQ. FRONTAL	SÍ	INOX 1.2	20/04/09	0.134
1	4817321	CONTRATAPA SARTEN 1200X900	SÍ	INOX 0.8	13/05/11	0.858
1	481701M	CONJUNTO CUBA MONTADA 1200x900	SÍ	INOX	10/02/11	71.309
1	481716M	DEFLECTOR MONTADO SARTEN 1200	SÍ	INOX	10/02/11	16.886
1	481722C	CONJUNTO PETO SARTEN 1200	SÍ	INOX	10/02/11	2.703
1	481725M	ARMAZON SARTEN 1200x900	SÍ	GALVA	10/02/11	31.250
1	481732C	CONJ.TAPA SARTEN 1200X900	SÍ	INOX	13/05/11	10.416
1	481739C	CONJ.FRONTAL M.SARTEN 1200	SÍ	INOX	21/10/10	3.853
1	481749C	CANAL ENCIMERA SARTEN 1200	SÍ	INOX 2	21/04/09	2.700
2	481789P	CENTRADOR MUELLE ASA SARTEN	SÍ	INOX D.28x1.5	07/02/11	0.090
6	TESTA35	ANGULO TESTATINA 35	SÍ	INOX 0.6	29/08/07	0.004
4	TESTA70	ANGULO TESTATINA 70	SÍ	INOX 0.6	29/08/07	0.008
12	1014	REMACHE ROSCADO M-10	NO	ZN	17/12/09	0.008
8	1042	TORNILLO M-10X25 DIN933 ZN	NO	ZN	17/12/09	0.029
2	1050	TORNILLO ALLEN M5X12 DIN912	NO	INOX	22/05/09	0.004
8	1051	TORNILLO ZN M4X15 DIN 84	NO	FE ZN	01/01/09	0.003
6	1094	TORNILLO M-5X20 TLR INOX	NO	INOX	01/01/01	0.004
1	2193	CABLE PIEZO L=370	NO	FIBRA/CU	01/01/09	0.003
1	3103	VALVULA MINI SIT	NO	AL	01/01/09	0.700
1	3242	TUERCA LATON 1/2"	NO	INOX	27/11/00	0.009
1	3275	CASQUILLO ELEVACIÓN	NO	BRONCE	05/05/09	0.209
1	3747	PIEZO ELECTRICO SIT	NO	PLAST	05/09/08	0.076
1	3765	MANDO VALV. SIT	NO	PLASTICO	01/01/09	0.014



FAMILIA: COCINAS 2008

FECHA: 10/02/11

MODELO: 4817 - HSB120 - ST120G

PESO(Kg): 174.858

DENOMINACION:
SARTEN BASCULANTE 1200x900 GAS

ESCALA:
1/10

MATERIAL:
INOX

CODIGO:
4817



Applus®
LGA1
Organismo
Notificado
0370

AENOR
Organismo
Notificado
0099



TOLERANCIAS GENERALES: ±0.5 mm

4	3781	TUERCA M16X1.5 D.10	NO	LATON	05/09/08	0.015
4	3782	BICONO D.10 LATON	NO	LATON	01/01/09	0.001
2	3785	JUNTA VALVULA MINISIT	NO	GOMA	01/01/09	0.000
1	330189	MANGUITO M16X1.5 TUBO D.10	NO	FE	22/09/08	0.007
2	70430502	CAZOLETA PIÑON 2ª ESP.	NO	FE ZN	01/01/01	0.196
5	300187P	QUEMADOR TUBULAR D.40 L.400	NO	INOX	05/08/09	0.424
1	3103M	VALVULA SIT COMPLETA	NO	AL	05/09/08	0.940
2	362489P	MACHON D.10 - 3/8" - M16X1.5	NO	LATON	01/10/08	0.029
1	480322P	EJE BISAGRA	NO	INOX	25/08/09	1.199
2	480389P	TERMINAL TUBO BISAGRA	NO	FE CR	22/07/09	0.221
1	480393P	ASA MARMITA-SARTEN 900	NO	INOX	18/11/09	2.490
2	481240P	SOPORTE BISAGRA SARTEN	NO	FE 20 CR	20/11/09	0.467
1	481289P	MACHON D.10 - 1/2" - M16X1.5	NO	LATON	15/12/09	0.026
1	481293PM	CONJ.ASA SARTEN 900	NO	INOX	07/02/11	6.440
1	481701C	CONJUNTO CUBA SOLDADA 1200X900	NO	INOX	10/02/11	66.992
1	481701P	CUBA SARTEN 1200X900	NO	INOX 2.5	10/02/11	60.437
1	481703P	EJE ELEVACION SARTEN	NO	FE	05/06/10	1.351
2	481715P	COSTILLA BISAGRA CUBA	NO	FE 8 PAV	18/05/09	3.278
1	481724P	COSTILLA TRASERA	NO	FE 8 PAV	08/06/09	2.165
2	481725P	COSTILLA BISAGRA MUEBLE	NO	FE 8 PAV	08/06/09	3.266
1	481786P	COLECTOR 5 SALIDAS	NO	FE	27/03/09	0.428
1	481786PC	COLECTOR 5 SALIDAS	NO	FE ZINCADO	27/03/09	0.441
1	4817931P	BIELA ELEVACION PLANA	NO	FE 8 PAV	25/01/11	3.697
1	A1018996	RACORD BUJIA	NO	LATON	01/01/09	0.004
1	A1018997	RACORD PILOTO	NO	LATON	01/01/09	0.004
1	A1018998	RACORD TERMOPAR	NO	LATON	01/01/09	0.004
1	A1018999	BICONO PILOTO	NO	LATON	01/01/09	0.002
6	C1061459	TORNILLO M-6X10 TLR INOX	NO	INOX	20/05/09	0.004
2	C1062003	TORNILLO M-5X15 DIN933 ZN	NO	FE ZN	03/02/09	0.003
6	C1063259	TORNILLO M-8X20 TLR INOX	NO	INOX	22/07/09	0.012
8	C1064063	TORNILLO M-6X15 DIN933 ZN	NO	FE ZN	17/12/09	0.006
2	C1064343	TORNILLO M-6X40 DIN 963 INOX	NO	INOX	22/07/09	0.011
1	C1065128	TORNILLO M-8x500 DIN931 R.PAR.	NO	INOX	07/02/11	0.026
4	C1065499	TORNILLO M-8X16 DIN933 INOX	NO	INOX	16/12/09	0.012
4	C1066269	TORNILLO M-10X40 DIN933 ZN	NO	ZN	17/12/09	0.038
8	C1160063	TUERCA M-6 DIN934	NO	FE ZN	17/12/09	0.002
4	C1160103	TUERCA M-8 DIN934	NO	FE ZN	17/12/09	0.004
2	C1160543	TUERCA M-18X1.5 DIN 936	NO	FE ZN	01/01/01	0.023
2	C1660061	REMACHE ROSCADO M-5	NO	Fe ZN	24/03/11	0.002
1	C5810129	PILOTO POLIDORO	NO	FE	01/01/09	0.053
1	C5810129M	PILOTO POLIDORO COMPLETO	NO	FE	28/01/11	0.074
1	C5810139	BUJIA	NO	CER	01/01/09	0.004
1	C5810159	INY.PILOTO GN (27.2) 2 AGUJ.	NO	LATON	01/01/09	0.002
1	C5810169	INY.PILOTO GLP (22) 1 AGUJ.	NO	LATON	01/01/09	0.002
2	C5810419	CODO 90° -3/8" SIT S/R.0906252	NO	AL	01/01/09	0.054
5	C5812649	INY. D.110 GLP QUEM. L.400	NO	LATON	01/01/09	0.012
5	C5812669	INY. D.160 GN QUEM.L.400	NO	LATON	01/01/09	0.012
1	C5815359	TUERCA+BICONO D.6 M10X1	NO	LATON	01/01/09	0.006
1	C5820049	TERMOPAR LISO M9X1 L 320	NO	CU	01/01/09	0.018



FAMILIA: COCINAS 2008

FECHA: 10/02/11

MODELO: 4817 - HSB120 - ST120G

PESO(Kg): 174.858

DENOMINACION:
SARTEN BASCULANTE 1200x900 GAS

ESCALA:
1/10

MATERIAL:
INOX

CODIGO:
4817



Applus[®]
LGAI
Organismo
Notificado
0370

AENOR
Organismo
Notificado
0099



TOLERANCIAS GENERALES: ±0.5 mm

2	C6060209	COJINETE UCP-202-FK	NO	FE	16/04/09	0.690
2	C6260239	CUERPO SOPORTE BISAGRA D.50	NO	FE	22/07/09	0.381
1	C6260339	MUELLE DCHO.L.85 D.42.5 E.5	NO	FE	22/07/09	0.154
1	C6260349	MUELLE IZQ.L.85 D.42.5 E.5	NO	FE	22/07/09	0.154
4	C6260511	PATA INOX 130-200 (S_F)	NO	INOX	01/01/09	0.320
1	C6262619	VOLANTE MACIZO PLEGABLE D.200	NO	INOX	23/11/09	3.144
1	T06045	TUBO AL D.6 L.450	NO	AL 99.7%	13/05/09	0.015
1	T10030	TUBO AL D.10 L.300	NO	AL 99.7%	13/05/09	0.031



FAMILIA: COCINAS 2008

FECHA: 10/02/11

MODELO: 4817 - HSB120 - ST120G

PESO(Kg): 174.858

DENOMINACION:
SARTEN BASCULANTE 1200x900 GAS

ESCALA:
1/15

MATERIAL:
INOX

CODIGO:
4817



ISO 9001
BUREAU VERITAS
Certification



ISO 14001
BUREAU VERITAS
Certification



Applus®
LGAI
Organismo
Notificado
0370

AENOR
Organismo
Notificado
0099

FUNDADA EN 1878
MASBAGA
GRANDES COCINAS

EURAST

mag-Tin

TOLERANCIAS GENERALES: ±0.5 mm

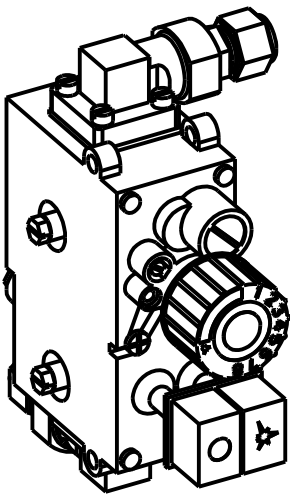

QT	COD	DESCRIPCION
8	1051	TORNILLO ZN M4X15 DIN 84
1	3103	VALVULA MINI SIT
1	3765	MANDO VALV. SIT
2	3781	TUERCA M16X1.5 D.10
2	3782	BICONO D.10 LATON
2	3785	JUNTA VALVULA MINISIT
2	362489P	MACHON D.10 - 3/8" - M16X1.5
2	C5810419	CODO 90° -3/8" SIT S/R.0906252
1	C5815359	TUERCA+BICONO D.6 M10X1

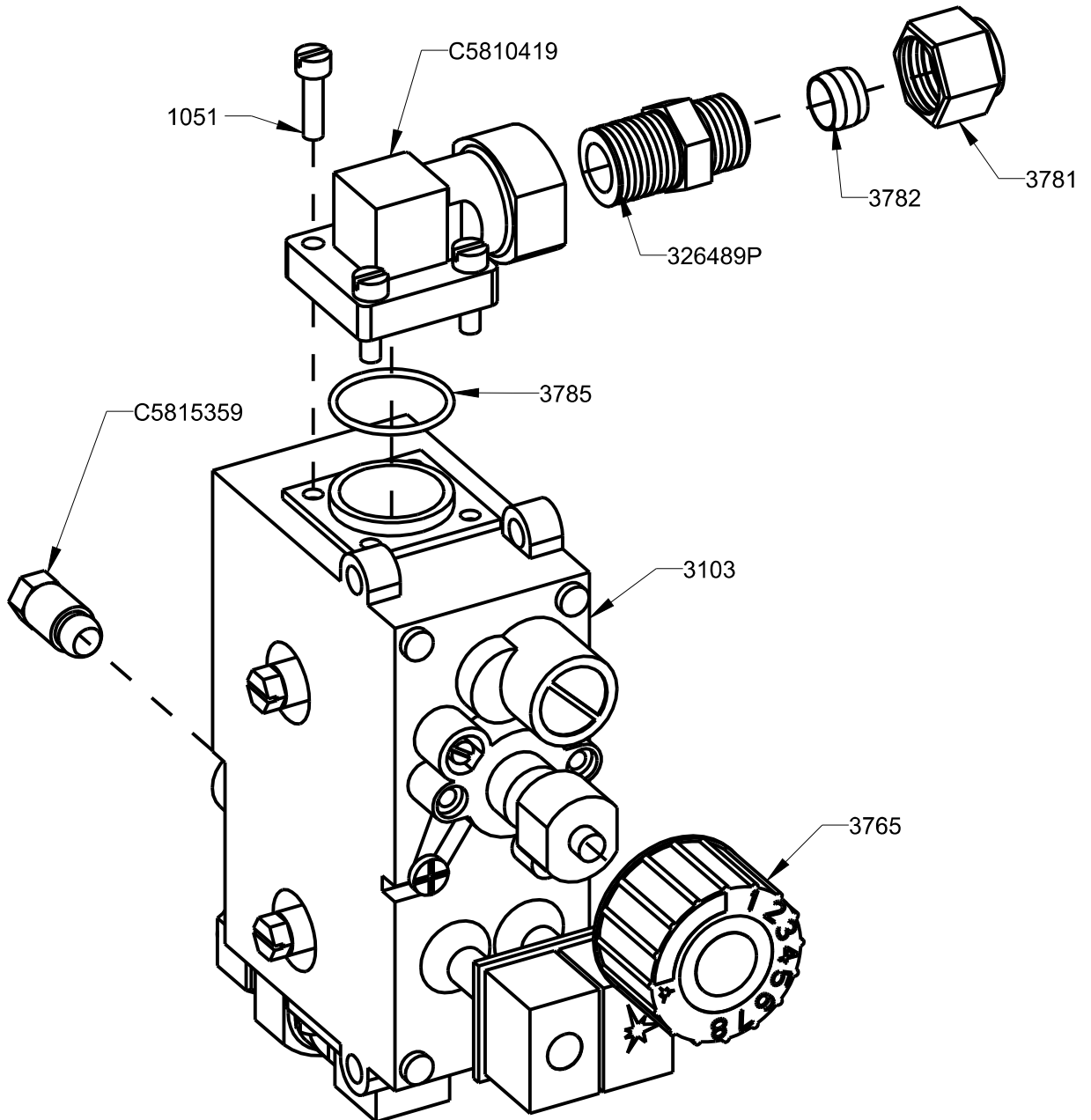

FAMILIA: COCINAS 2008

FECHA: 05/09/08

MODELO: 3611

PESO(Kg): 0.940

DENOMINACION:
VALVULA SIT COMPLETA

ESCALA:
1/2

MATERIAL:
AL

CODIGO:
3103M



Applus®
LGA1
Organismo Notificado
0370

AENOR
Organismo Notificado
0099

FUNDADA EN 1878
MASBAGA
GRANDES COCINAS

EURAST

mac-fini

TOLERANCIAS GENERALES: ±0.5 mm

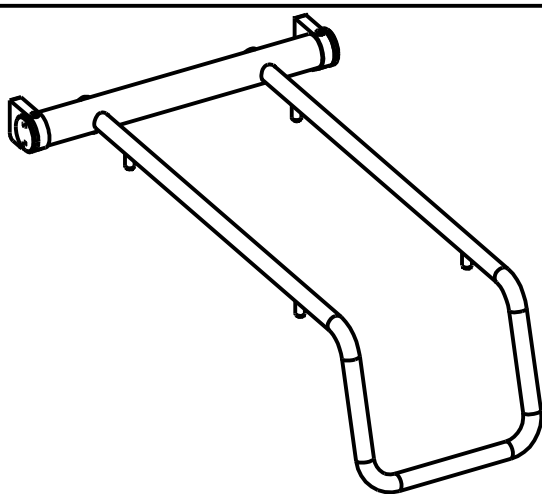

QT	COD	DESCRIPCION
2	1050	TORNILLO ALLEN M5X12 DIN912
1	480322P	EJE BISAGRA
2	480389P	TERMINAL TUBO BISAGRA
1	480393P	ASA MARMITA-SARTEN 900
2	481240P	SOPORTE BISAGRA SARTEN
2	481789P	CENTRADOR MUELLE ASA SARTEN
6	C1061459	TORNILLO M-6X10 TLR INOX
6	C1063259	TORNILLO M-8X20 TLR INOX
2	C1064343	TORNILLO M-6X40 DIN 963 INOX
2	C6260239	CUERPO SOPORTE BISAGRA D.50
1	C6260339	MUELLE DCHO.L.85 D.42.5 E.5
1	C6260349	MUELLE IZQ.L.85 D.42.5 E.5

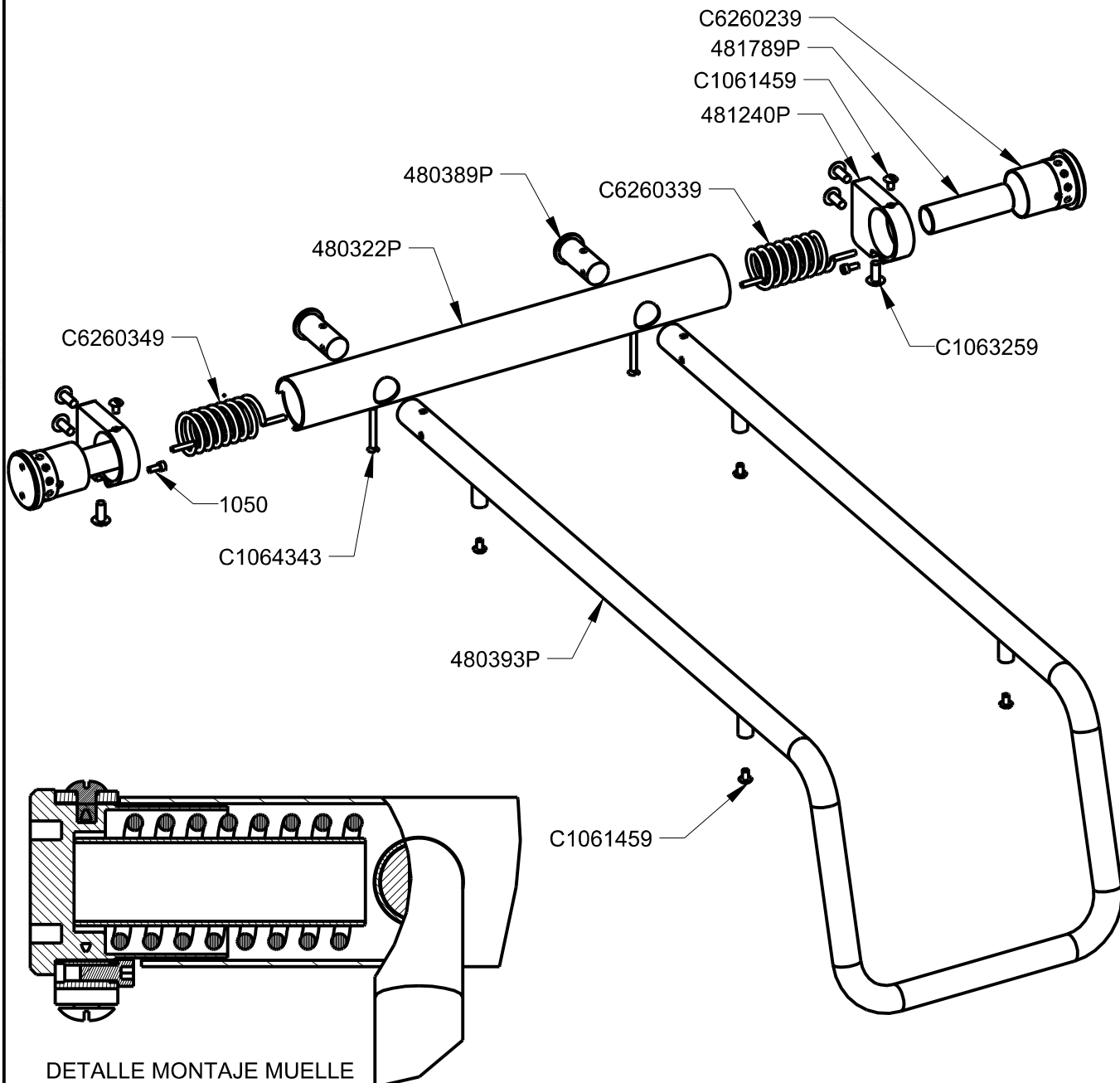

FAMILIA: COCINAS 2008

FECHA: 07/02/11

MODELO: 4812

PESO(Kg): 6.440

DENOMINACION:
CONJ.ASA SARTEN 900

ESCALA:
1/8

MATERIAL:
INOX

CODIGO:
481293PM



Applus®
LGA1
Organismo
Notificado
0370

AENOR
Organismo
Notificado
0099



TOLERANCIAS GENERALES: ± 0.5 mm

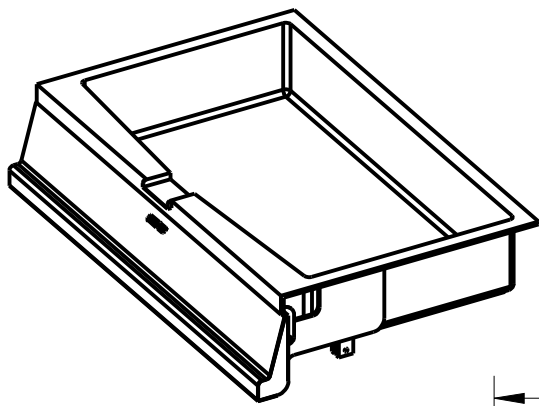

QT	COD	DESCRIPCION
6	1094	TORNILLO M-5X20 TLR INOX
2	70430502	CAZOLETA PIÑON 2ª ESP.
1	481701C	CONJUNTO CUBA SOLDADA 1200X900
1	481739C	CONJ.FRONTAL M.SARTEN 1200
2	C1160543	TUERCA M-18X1.5 DIN 936

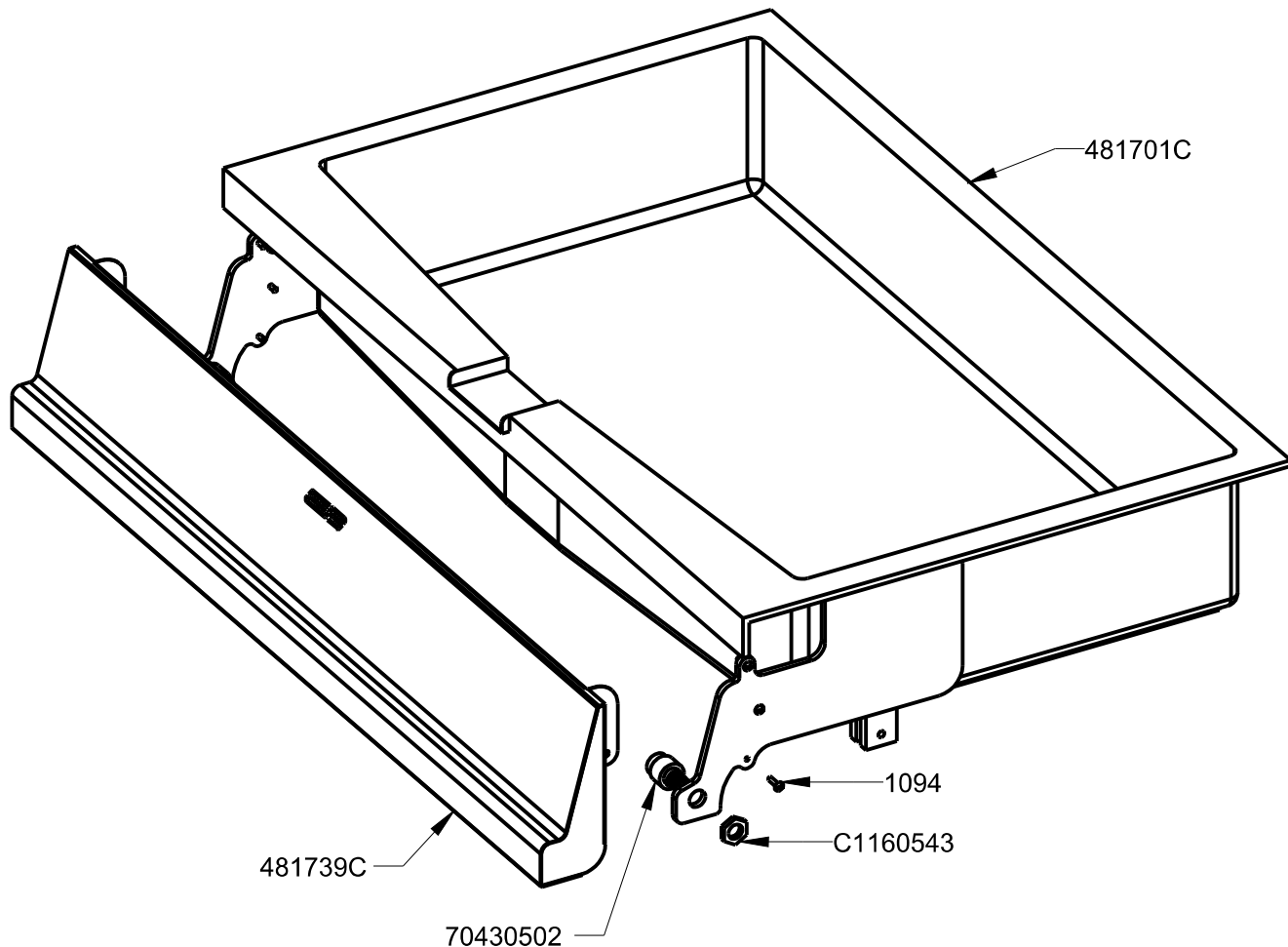
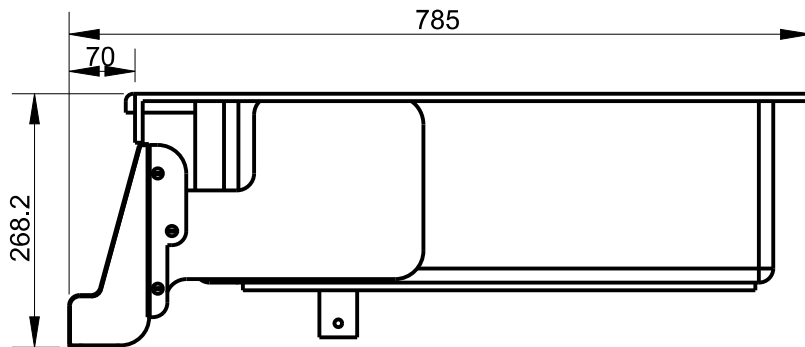

FAMILIA: COCINAS 2008

FECHA: 10/02/11

MODELO: 4817

PESO(Kg): 71.309

DENOMINACION:
CONJUNTO CUBA MONTADA 1200x900

ESCALA:
1/8

MATERIAL:
INOX

CODIGO:
481701M



Applus®
LGA1
Organismo
Notificado
0370

AENOR
Organismo
Notificado
0099



TOLERANCIAS GENERALES: ±0.5 mm

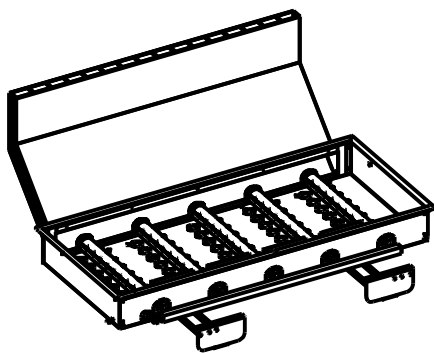

QT	COD	DESCRIPCION
1	2193	CABLE PIEZO L=370
1	3781	TUERCA M16X1.5 D.10
1	3782	BICONO D.10 LATON
4	300388	CORRELLAMAS
2	481278	TAPETA LATERAL DEFLECTOR
1	481716	DEFLECTOR SARTEN 1200
1	481726	BURL.CERAM.SARTEN 1200x900-C6580179
2	481748	OMEGA FIJACIÓN DEFLECTOR
1	481752	SALIDA VAHOS SARTEN 1200
5	300187P	QUEMADOR TUBULAR D.40 L.400
1	481786PC	COLECTOR 5 SALIDAS
1	C5810129M	PILOTO POLIDORO COMPLETO
5	C5812649	INY. D.110 GLP QUEM. L.400
5	C5812669	INY. D.160 GN QUEM.L.400
1	C5820049	TERMOPAR LISO M9X1 L 320

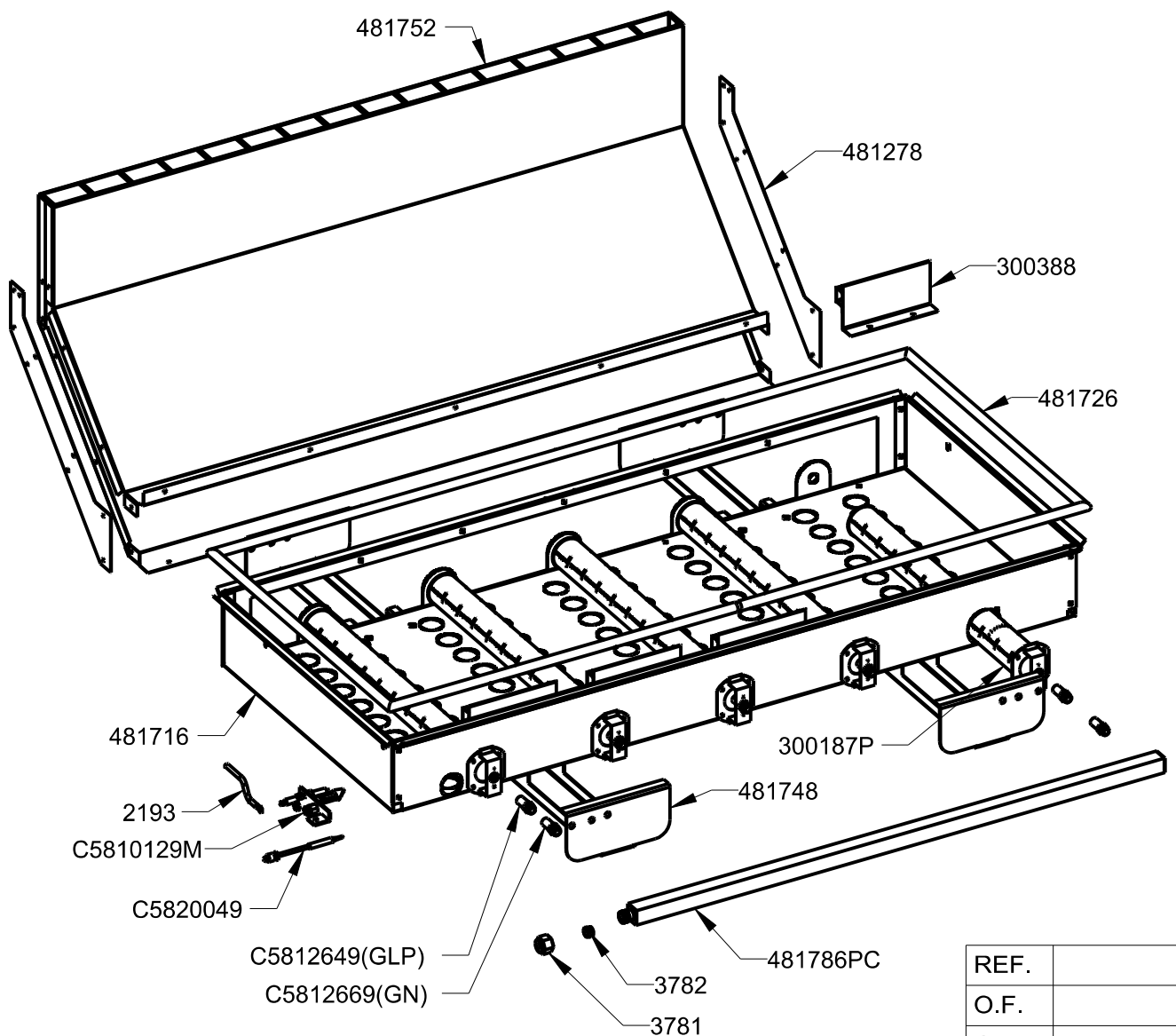

REF.	
O.F.	
QT.	
DEST.	



FAMILIA: COCINAS 2008

FECHA: 10/02/11

MODELO: 4817

PESO(Kg): 16.886

DENOMINACION:
DEFLECTOR MONTADO SARTEN 1200

ESCALA:
1/8

MATERIAL:
INOX

CODIGO:
481716M



Applus®
LGA1
Organismo
Notificado
0370

AENOR
Organismo
Notificado
0099



TOLERANCIAS GENERALES: ±0.5 mm

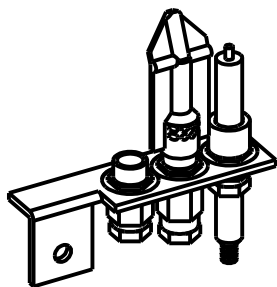

ESCALA 1/2

QT	COD	DESCRIPCION
1	A1018999	BICONO PILOTO
1	C5810139	BUJIA
1	C5810169	INY.PILOTO GLP (22) 1 AGUJ.
1	C5810159	INY.PILOTO GN (27.2) 2 AGUJ.
1	C5810129	PILOTO POLIDORO
1	A1018996	RACORD BUJIA
1	A1018997	RACORD PILOTO
1	A1018998	RACORD TERMOPAR

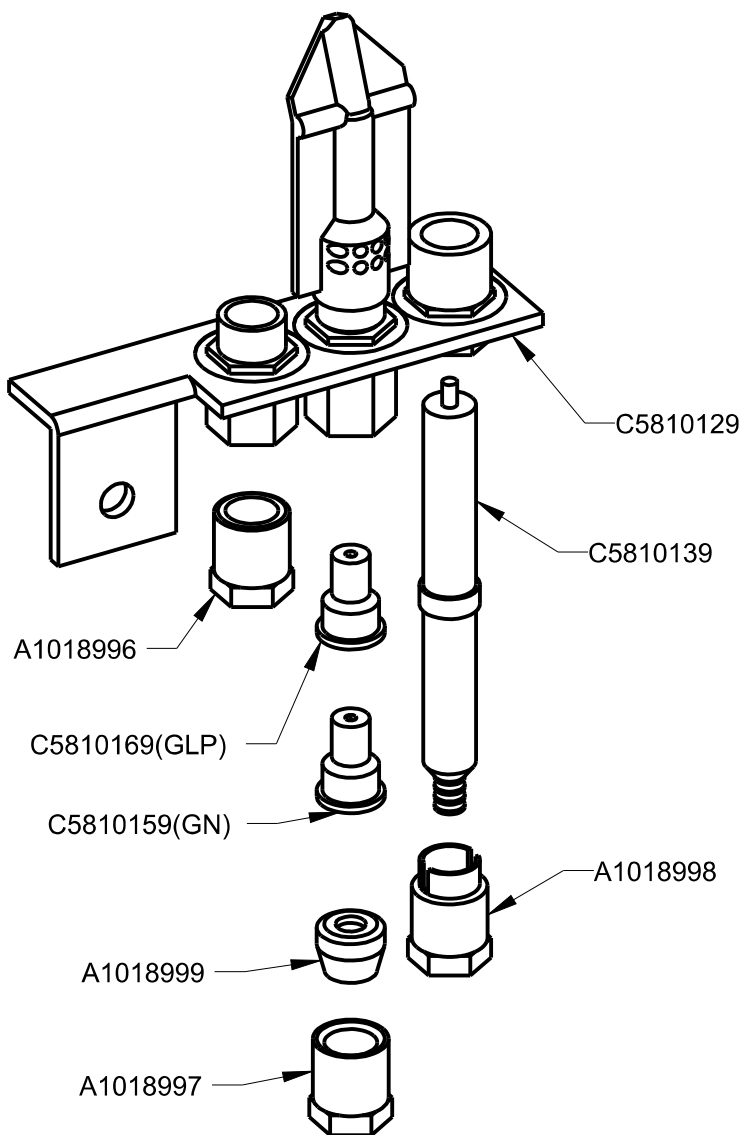

FAMILIA: COCINAS 2008

FECHA: 28/01/11

MODELO: 3611

PESO(Kg): 0.074

DENOMINACION:
PILOTO POLIDORO COMPLETO

ESCALA:
1/1

MATERIAL:
FE

CODIGO:
C5810129M



Applus®
LGA1
Organismo
Notificado
0370

AENOR
Organismo
Notificado
0099



TOLERANCIAS GENERALES: ±0.5 mm

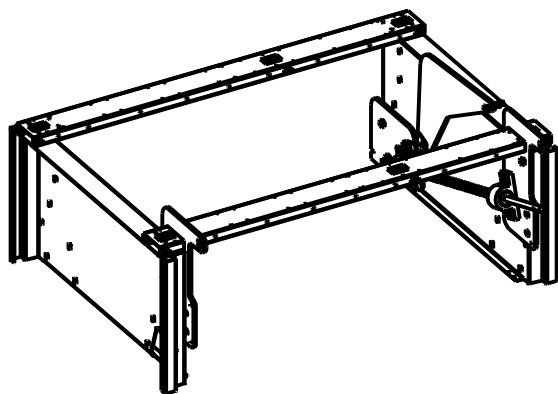

QT	COD	DESCRIPCION
12	1014	REMACHE ROSCADO M-10
8	1042	TORNILLO M-10X25 DIN933 ZN
1	3275	CASQUILLO ELEVACIÓN
2	350204	OMEGA COCINA 1200
1	481276	SOPORTE BIELA SARTEN B.
2	481725	LATERAL INTERIOR SARTEN 900
1	481703P	EJE ELEVACION SARTEN
1	481724P	COSTILLA TRASERA
2	481725P	COSTILLA BISAGRA MUEBLE
1	4817931P	BIELA ELEVACION PLANA
2	C1062003	TORNILLO M-5X15 DIN933 ZN
8	C1064063	TORNILLO M-6X15 DIN933 ZN
1	C1065128	TORNILLO M-8x500 DIN931 R.PAR.
4	C1065499	TORNILLO M-8X16 DIN933 INOX
4	C1066269	TORNILLO M-10X40 DIN933 ZN
8	C1160063	TUERCA M-6 DIN934
4	C1160103	TUERCA M-8 DIN934
2	C1660061	REMACHE ROSCADO M-5
2	C6060209	COJINETE UCP-202-FK

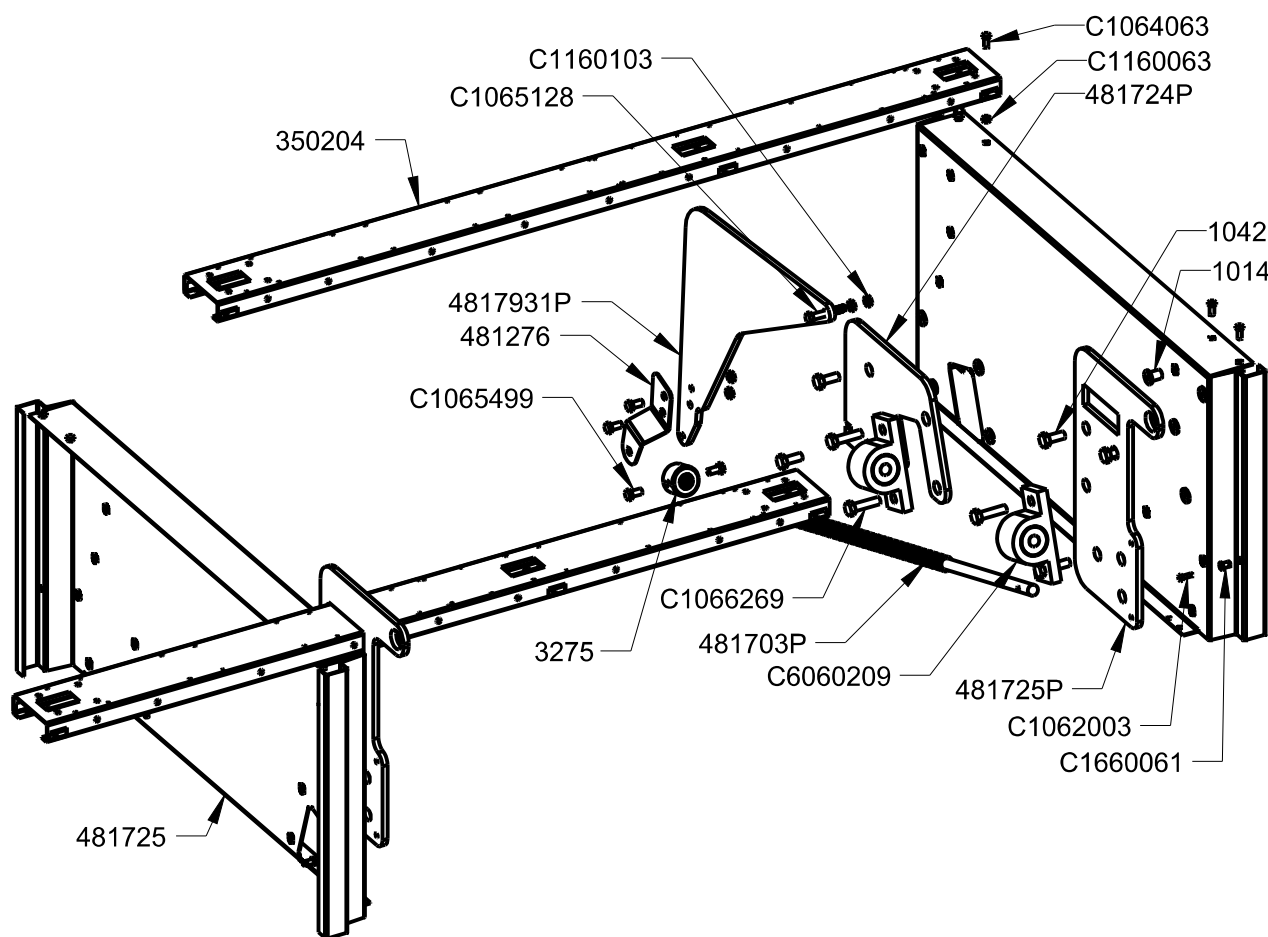

FAMILIA: COCINAS 2008

FECHA: 10/02/11

MODELO: 4817

PESO(Kg): 31.250

DENOMINACION:
ARMAZON SARTEN 1200x900

ESCALA:
1/10

MATERIAL:
GALVA

CODIGO:
481725M