

# NME650 & FME800 SERVICE PARTS

This parts list contains the service parts and wiring diagrams for this model. Check the model number in question to be sure that it is applicable to this parts list.

Caution: This model ice maker has been manufactured in two voltages: 115/60/1 and 230/50/1.

The model numbers for the 115/60/1 include:

FME800AE-1A and FME800WE-1A

NME650AE-1A and NME650WE-1A

The model numbers for the 230/50/1 include:

FME800AE-6A and FME800WE-6A

FME800AE-6B and FME800WE-6B

NME650AE-6A and NME650WE-6A

NME650AE-6B and NME650WE-6B

For electrical components, check to be certain that the part is the correct voltage for the machine.

**Note: The liquid line filter drier listed in this parts list is designed for this refrigeration system. Premature refrigeration system failure may result if the wrong drier is used.**

## TABLE OF CONTENTS

|                                      |    |
|--------------------------------------|----|
| Cabinet . . . . .                    | 2  |
| Air Cooled Refrigeration . . . . .   | 3  |
| Water Cooled Refrigeration . . . . . | 4  |
| Water System . . . . .               | 5  |
| Gearmotor . . . . .                  | 6  |
| FME800 Evaporator . . . . .          | 7  |
| NME650 Evaporator . . . . .          | 8  |
| Control Box . . . . .                | 9  |
| Wiring Diagrams . . . . .            | 10 |

# NME650 & FME800 SERVICE PARTS

## Cabinet Assembly

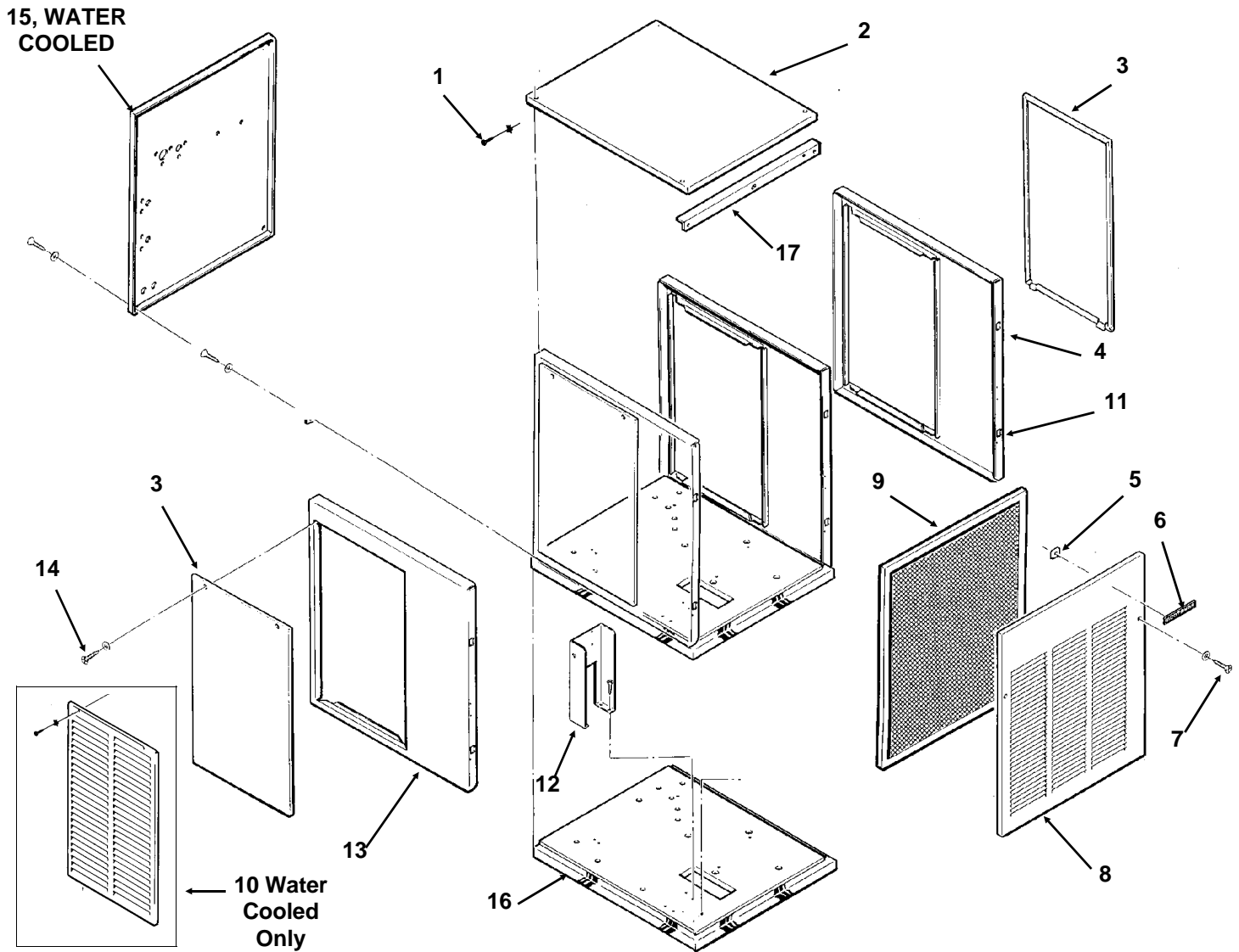

| ITEM NUMBER | PART NUMBER | DESCRIPTION                     | ITEM NUMBER | PART NUMBER                                   | DESCRIPTION                     |
|-------------|-------------|---------------------------------|-------------|---|---------------------------------|
| 1           | 03-1531-01  | Screw                           | 10          | Only for water cooled models (left or right): |                                 |
| 2           | A33256-001  | Top panel, sandalwood           | A33946-032  | Louvered panel, for SS                        |                                 |
|             | A33256-002  | Top panel, S.S.                 | A32161-001  | Louvered panel, for s-wood                    |                                 |
| 3           | A34038-001  | Air cooled srcv pnl, sandalwood | A32161-015  | Louvered panel for gray                       |                                 |
|             | A34038-015  | Air cooled service panel, gray  | 11          | 02-0836-00                                    | Catch                           |
|             | A34038-002  | Air cooled service panel, S.S.  |             | 15-0411-00                                    | Strike                          |
| 4           | A33292-001  | Right side panel, sandalwood    |             | 03-1406-04                                    | Nut                             |
|             | A33292-002  | Right side panel, S.S.          | 12          | A34039-001                                    | Control Box Support             |
| 5           | 03-0271-00  | Speed Clip                      | 13          | A32435-001                                    | Left side panel, sandalwood     |
| 6           | 15-0808-01  | Emblem                          |             | A32435-015                                    | Left side panel, gray           |
| 7           | 03-1419-22  | Screw                           |             | A32435-002                                    | Left side panel, S.S.           |
| 8           | A33255-001  | Front panel, sandalwood         | 14          | 03-1404-12                                    | Screw                           |
|             | A33255-015  | Front panel, gray               | 15          | A35924-001                                    | Rear panel, water cooled s-wood |
|             | A33255-002  | Front panel, S.S.               |             | A35924-002                                    | Rear panel, water cooled, SS    |
| 9           | 02-2976-01  | Air Filter (air cooled only)    |             | A35924-015                                    | Rear panel, gray                |
|             | 03-1660-01  | Filter clip                     | 16.         | A35890-020                                    | Base                            |
|             |             |                                 | 17          | A34348-001                                    | Front Brace, Air Cooled         |

# NME650 & FME800 SERVICE PARTS

## Air Cooled Refrigeration

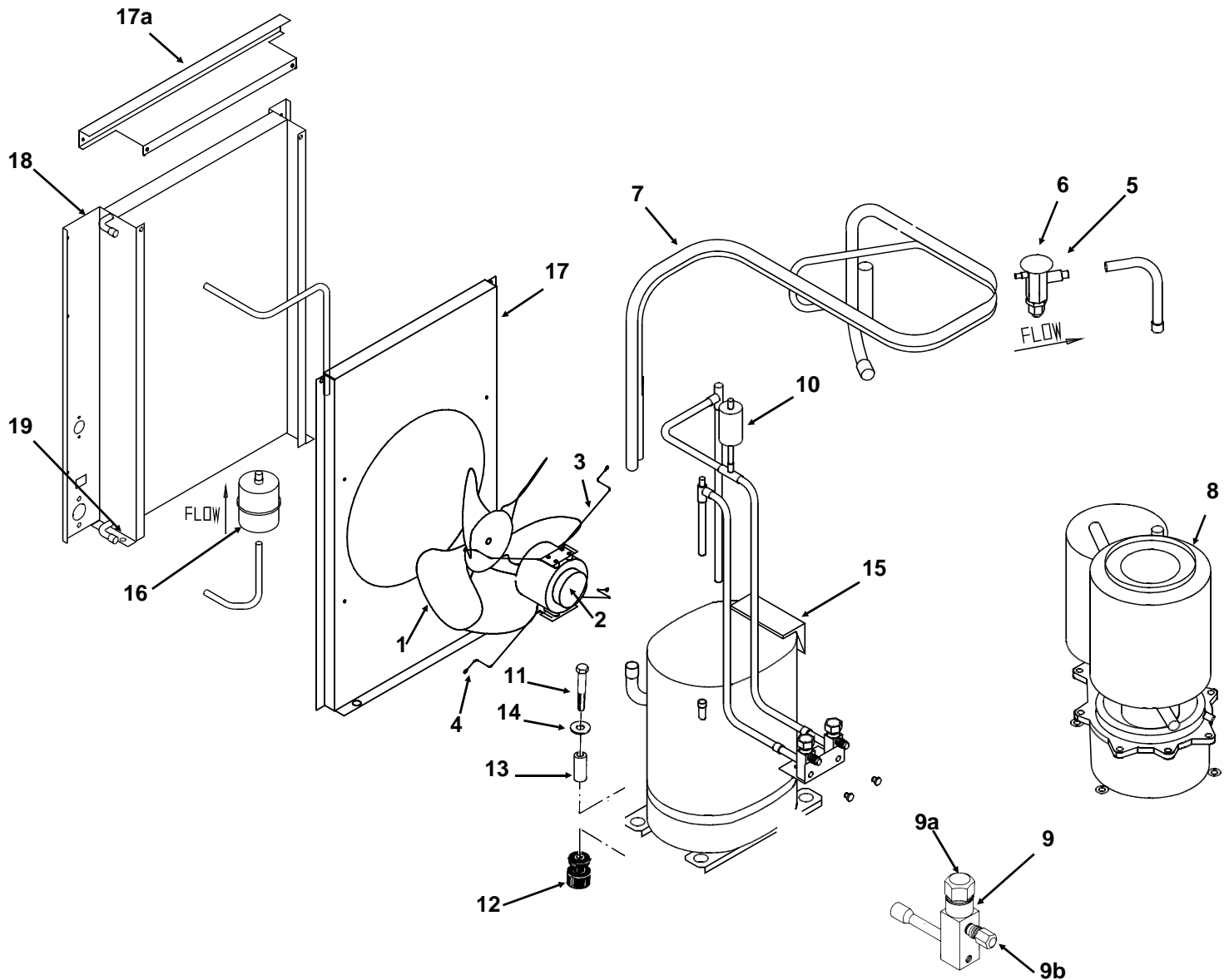

| ITEM NUMBER | PART NUMBER | DESCRIPTION              | ITEM NUMBER                     | PART NUMBER | DESCRIPTION                   |
|-------------|-------------|--------------------------|---------------------------------|-------------|-------------------------------|
| 1           | 18-8747-01  | Fan blade                | 12                              | 18-2200-28  | Grommet                       |
| 2           | 18-8736-01  | Fan motor, 115v/60 Hz    | 13                              | 18-2200-27  | Sleeve                        |
|             | 18-8736-04  | Fan motor, 230v/50 Hz    | 14                              | 03-1407-07  | Washer                        |
| 3           | 02-2378-02  | Fan Bracket              | 15                              | 18-8721-21  | Compressor 115v/60 Hz         |
| 4           | 03-1531-01  | Screw                    |                                 | 18-8711-50  | Overload for 115 v            |
| 5           | A32961-020  | Insulation Kit (3 piece) |                                 | 18-8721-22  | Compressor 230v/50 Hz         |
| 6           | 11-0488-21  | Thermo Expansion Valve   |                                 | 18-8721-50  | Overload for 50 Hz compressor |
| 7           | A35870-001  | Suction Line             | 16                              | 02-3319-02  | Dryer                         |
| 8           | A33194-020  | Evaporator - see page 7  | 17                              | A35886-001  | Fan Shroud                    |
| 9           | 16-0832-20  | Access valve             | 17a                             | A35582-001  | Fan shroud cover              |
| 9a          | 16-0832-02  | Stem cap                 | 18                              | 18-8734-01  | Condenser                     |
| 9b          | 16-0832-03  | Core cap                 | 19                              | 03-1645-01  | Screw                         |
| 10          | 11-0485-21  | Hi Pressure Cut Out      | NME650 -6B or FME800 - 6B only: |             |                               |
| 11          | 03-1645-01  | Screw                    | 21                              | 11-0512-01  | Low pressure cut out switch   |

# NME650 & FME800 SERVICE PARTS

## Water Cooled Refrigeration

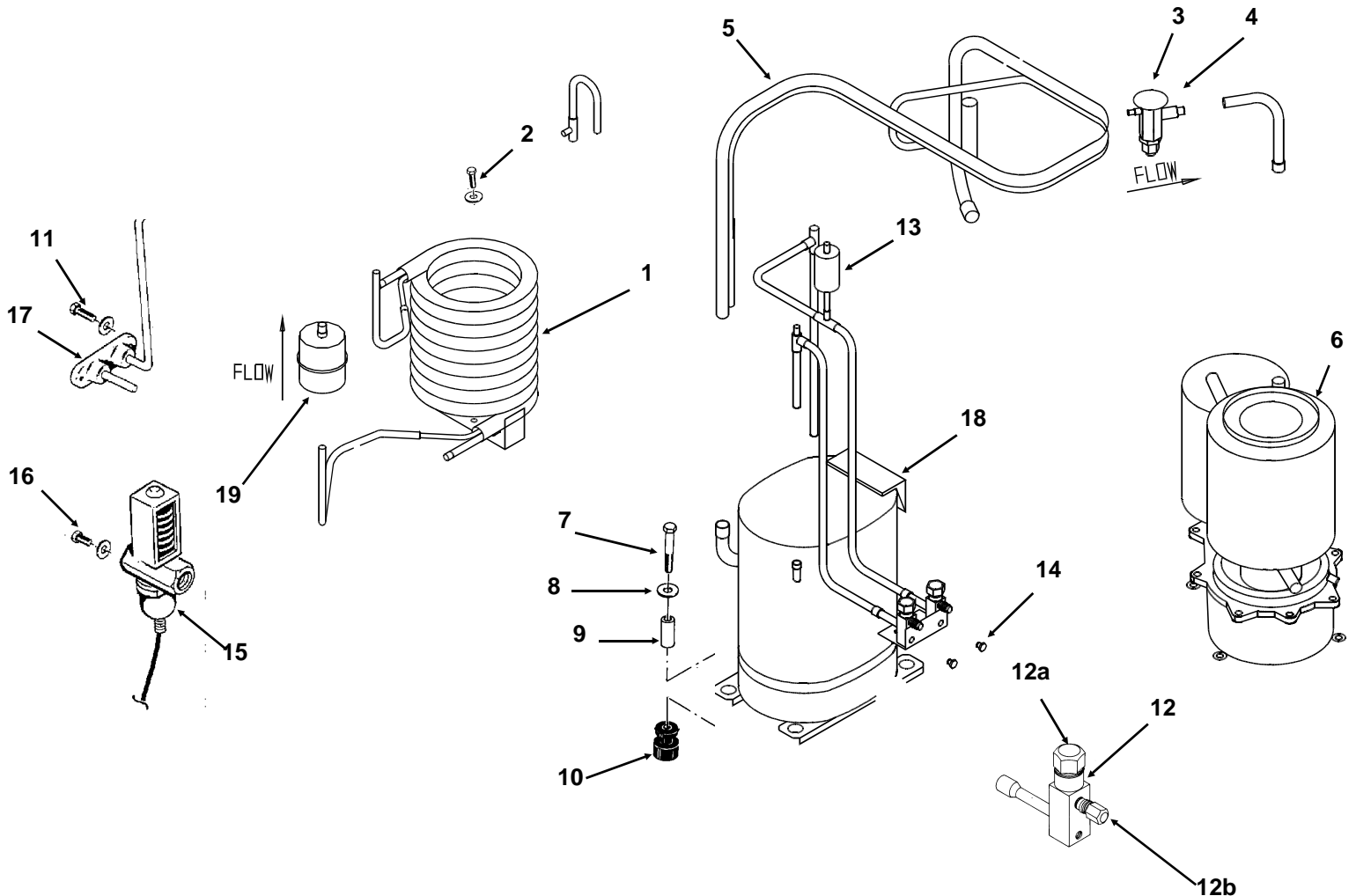

| ITEM NUMBER | PART NUMBER | DESCRIPTION              |
|-------------|-------------|--------------------------|
| 1           | 18-3306-25  | Condenser                |
| 2           | 03-1645-01  | Screw                    |
| 3           | 11-0488-21  | Thermo Expansion Valve   |
| 4           | A32961-020  | Insulation Kit (3 piece) |
| 5           | A35870-001  | Suction Line             |
| 6           | A33194-020  | Evaporator - see page 7  |
| 7           | 03-1405-20  | Cap Screw                |
| 8           | 03-1407-07  | Washer                   |
| 9           | 18-2200-27  | Sleeve                   |
| 10          | 18-2200-28  | Grommet                  |
| 11          | 03-1645-01  | Screw                    |
| 12          | 16-0832-20  | Access valve             |
| 12a         | 16-0832-02  | Stem cap                 |
| 12b         | 16-0832-03  | Core cap                 |

| ITEM NUMBER                     | PART NUMBER | DESCRIPTION                   |
|---------------------------------|-------------|-------------------------------|
| 13                              | 11-0485-21  | Hi Pressure Cut Out           |
| 14                              | 03-0571-02  | Screw                         |
| 15                              | 11-0478-01  | Water Reg. Valve              |
| 16                              | 03-1403-14  | Screw                         |
| 17                              | A34543-001  | Drain Assembly (WC)           |
| 18                              | 18-8721-21  | Compressor 115/60/1           |
|                                 | 18-8711-50  | Overload 115v                 |
|                                 | 18-8721-22  | Compressor 230v/50 Hz         |
|                                 | 18-8721-50  | Overload for 50 Hz compressor |
| 19                              | 02-3319-02  | Dryer                         |
| NME650 -6B or FME800 - 6B only: |             |                               |
| 20                              | 11-0512-01  | Low pressure cut out switch   |

# NME650 & FME800 SERVICE PARTS

## Water System

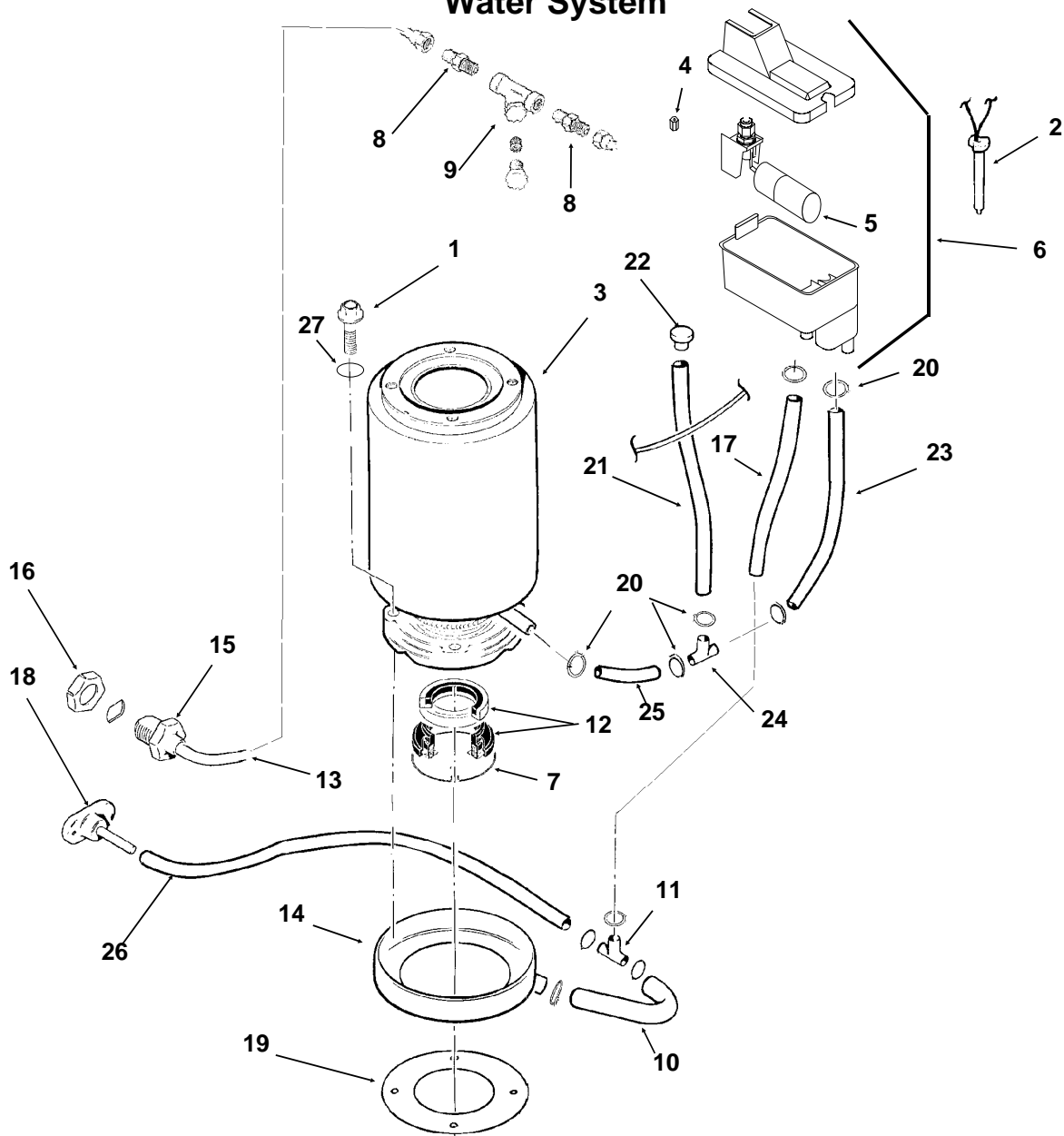

| ITEM NUMBER | PART NUMBER | DESCRIPTION                   | ITEM NUMBER | PART NUMBER | DESCRIPTION                |
|-------------|-------------|-------------------------------|-------------|-------------|----------------------------|
| 1           | 03-1420-03  | Cap Screw                     | 14          | 02-3837-01  | Drip Pan                   |
| 2           | A33101-022  | Water Level Sensor            | 15          | A27318-001  | Water Inlet Fitting        |
| 3           | A33194-020  | Evaporator                    | 16          | 03-1394-01  | Pal Nut                    |
| 4           | 02-3266-03  | Valve Seat                    | 17          | 13-0079-03  | Res. Overflow, 11" req.    |
| 5           | 02-3266-21  | Float valve & valve seat      | 18          | A32282-004  | Drain Casting, air cooled  |
| 6           | 02-3266-20  | Reservoir Assy Complete       | 19          | 13-0704-00  | Gasket                     |
|             | A36078-001  | Reservoir bracket (not shown) | 20          | 02-2814-08  | Clamps                     |
| 7           | A32777-001  | Retaining Ring for seal       | 21          | 13-0674-06  | Evap. Drain, 20" req.      |
| 8           | 16-0791-01  | Half Union                    | 22          | 13-0840-01  | Plug                       |
| 9           | 16-0162-00  | Strainer                      | 23          | 13-0674-06  | Evap. Inlet Tube, 10" req. |
| 10          | 13-0079-03  | Tube, 6" req.                 | 24          | 16-0670-01  | Tee                        |
| 11          | 16-0670-02  | Tee                           | 25          | A33203-001  | Tube, Preformed            |
| 12          | 02-0929-23  | Water Seal                    | 26          | 13-0079-03  | Drain Tube, 27" req.       |
| 13          | no number   | Water Inlet Tube              | 27.         | 03-1417-13  | Lockwasher                 |

# NME650 & FME800 SERVICE PARTS

## Gearmotor

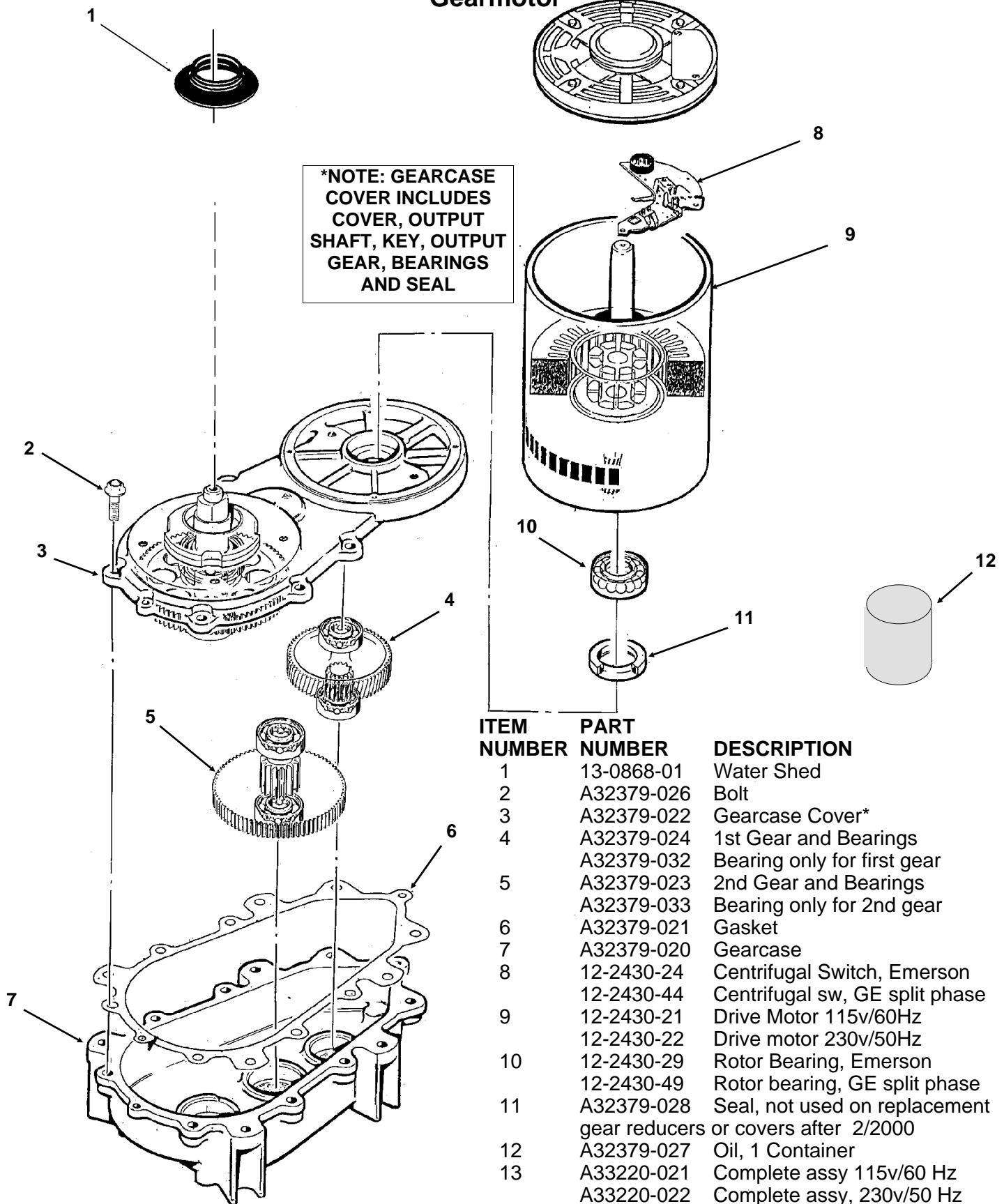

**\*NOTE: GEARCASE COVER INCLUDES COVER, OUTPUT SHAFT, KEY, OUTPUT GEAR, BEARINGS AND SEAL**

| ITEM NUMBER | PART NUMBER | DESCRIPTION  |
|-------------|-------------|--|
| 1           | 13-0868-01  | Water Shed   |
| 2           | A32379-026  | Bolt   |
| 3           | A32379-022  | Gearcase Cover*  |
| 4           | A32379-024  | 1st Gear and Bearings  |
|             | A32379-032  | Bearing only for first gear  |
| 5           | A32379-023  | 2nd Gear and Bearings  |
|             | A32379-033  | Bearing only for 2nd gear  |
| 6           | A32379-021  | Gasket   |
| 7           | A32379-020  | Gearcase   |
| 8           | 12-2430-24  | Centrifugal Switch, Emerson  |
|             | 12-2430-44  | Centrifugal sw, GE split phase                                     |
| 9           | 12-2430-21  | Drive Motor 115v/60Hz  |
|             | 12-2430-22  | Drive motor 230v/50Hz  |
| 10          | 12-2430-29  | Rotor Bearing, Emerson   |
|             | 12-2430-49  | Rotor bearing, GE split phase                                      |
| 11          | A32379-028  | Seal, not used on replacement gear reducers or covers after 2/2000 |
| 12          | A32379-027  | Oil, 1 Container   |
| 13          | A33220-021  | Complete assy 115v/60 Hz   |
|             | A33220-022  | Complete assy, 230v/50 Hz  |

The complete assembly includes the water shed and drip pan gasket.

A33220-030 Gears, oil & cases, no motor

# NME650 & FME800 SERVICE PARTS

## FME Evaporator

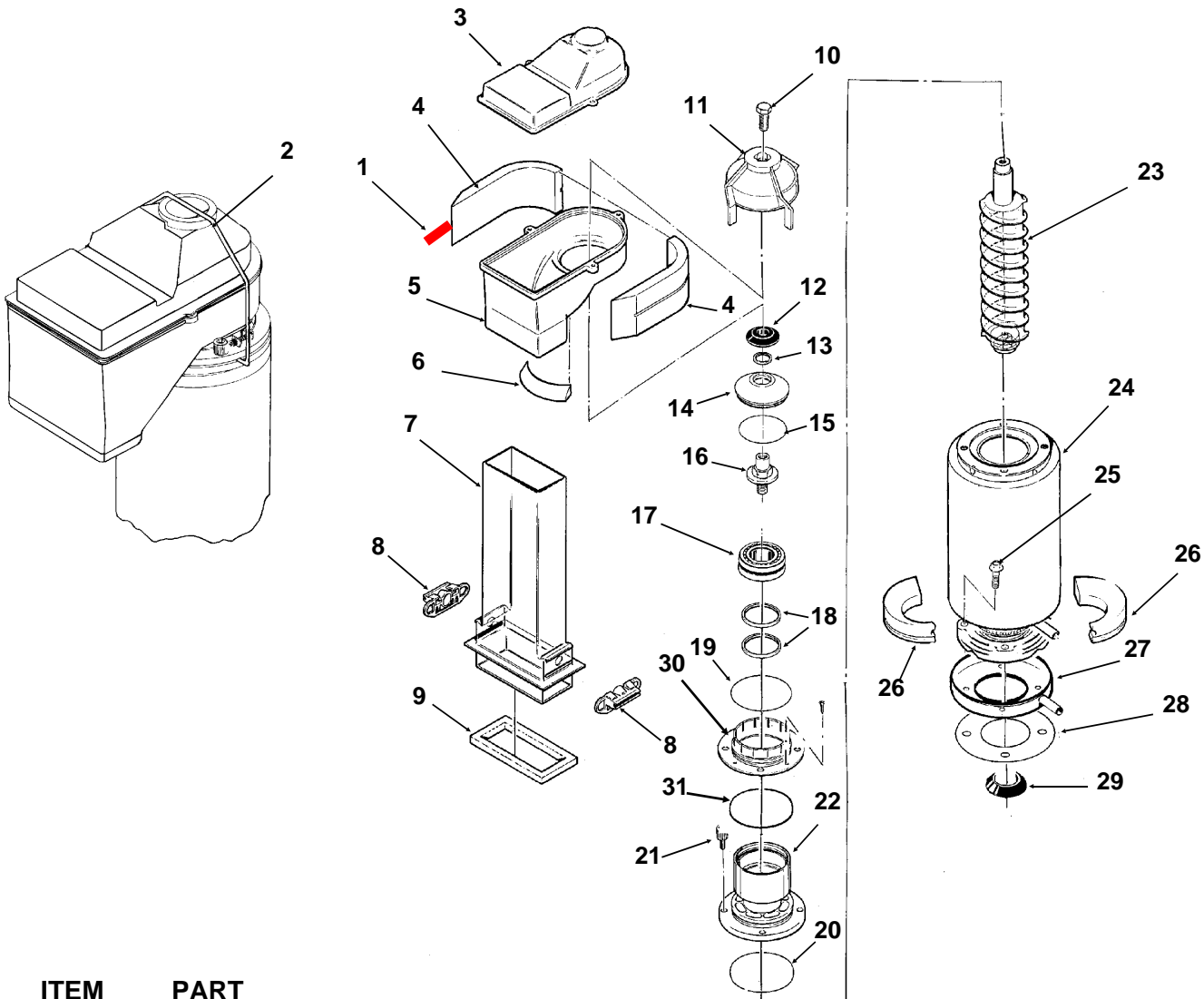

| ITEM NUMBER | PART NUMBER | DESCRIPTION                                |
|-------------|-------------|--|
| 1.          | A35419-020  | Strap kit                                  |
| 2.          | A34969-001  | Bail clamp                                 |
| 3.          | 02-2930-04  | Ice Chute Cover                            |
| 4.          | A32963-001  | Insulation Top (half)                      |
| 5.          | 02-3841-01  | Ice Chute Body                             |
| 6.          | A33102-001  | Insulation Collar Inside                   |
| 7.          | 02-2929-03  | Ice Chute Lower                            |
| 8.          | A37708-021  | Bin Controls Assy. (set of 2)              |
| 9.          | A32930-001  | Chute Gasket                               |
| 10.         | 03-1405-52  | Hex Cap Screw                              |
| 11.         | 02-3001-01  | Ice Sweep                                  |
| 12.         | 13-0871-01  | Water Shed                                 |
| 13.         | 02-2978-01  | Lip Seal                                   |
| 14.         | 02-3128-20  | Breaker Cover                              |
| 15.         | 13-0617-54  | O-Ring                                     |
| 16.         | 08-0660-01  | Auger Stud                                 |
| 17.         | A34559-020  | Bearing                                    |
| 18.         | 02-2977-01  | Lip Seal                                   |
| 19.         | 13-0617-52  | O-Ring                                     |
| 20.         | 13-0617-45  | O-Ring                                     |
| 21.         | 03-1544-08  | Soc. Head Screw                            |
| 22.         | A34505-020  | Breaker (includes 13, 14, 15, 17, 18 & 20) |
| 23.         | A38071-021  | Auger                                      |
| 24.         | A33194-020  | Evaporator                                 |
| 25.         | 03-1405-41  | Cap Screw                                  |
| 26.         | A32962-001  | Insulation Bot. (half)                     |
|             | A32962-002  | Insulation half                            |
| 27.         | A32050-001  | Drip Pan                                   |
| 28.         | 13-0704-00  | Drip Pan Gasket                            |
| 29.         | 13-0868-01  | Water Shed                                 |
| 30.         | 02-2916-01  | Slotted collar                             |
| 31.         | 13-0617-49  | O-Ring                                     |

# NME650 & FME800 SERVICE PARTS

## NME Evaporator

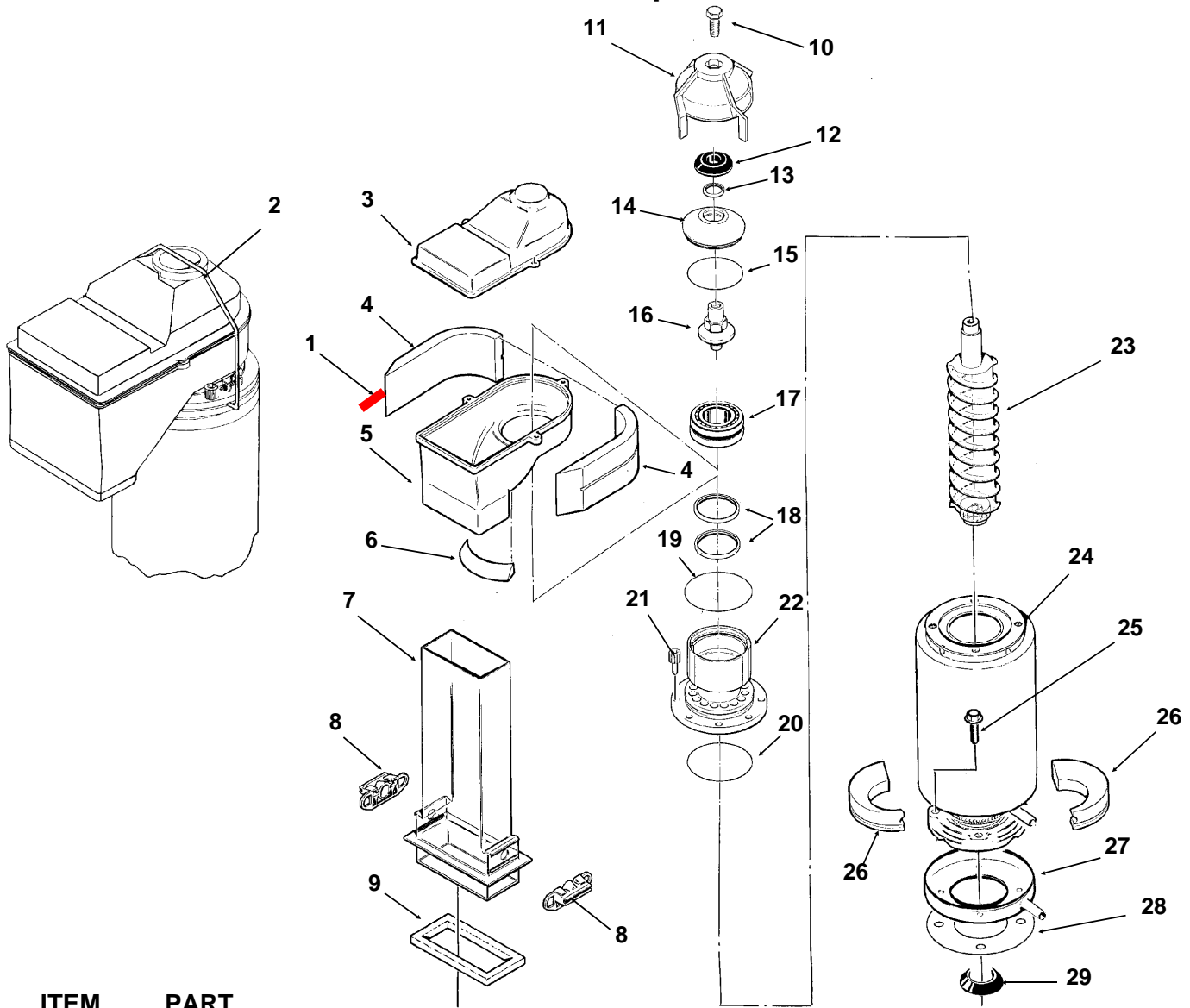

| ITEM NUMBER | PART NUMBER | DESCRIPTION                             |
|-------------|-------------|---|
| 1.          | A35419-020  | Strap kit                               |
| 2.          | A34969-001  | Bail clamp                              |
| 3.          | 02-2930-04  | Ice Chute Cover                         |
| 4.          | A32963-001  | Insulation Top (half)                   |
| 5.          | 02-3841-01  | Ice Chute Body                          |
| 6.          | A33102-001  | Insulation Collar Inside                |
| 7.          | 02-2929-03  | Ice Chute Lower                         |
| 8.          | A37708-021  | Bin Controls Assy. (set of 2)           |
| 9.          | A32930-001  | Chute Gasket                            |
| 10.         | 03-1405-52  | Hex Cap Screw                           |
| 11.         | 02-3001-01  | Ice Sweep                               |
| 12.         | 13-0871-01  | Water Shed                              |
| 13.         | 02-2978-01  | Lip Seal                                |
| 14.         | 02-3128-20  | Breaker Cover                           |
| 15.         | 13-0617-54  | O-Ring                                  |
| 16.         | 08-0660-01  | Auger Stud                              |
| 17.         | A34559-020  | Bearing                                 |
| 18.         | 02-2977-01  | Lip Seal                                |
| 19.         | 13-0617-52  | O-Ring                                  |
| 20.         | 13-0617-45  | O-Ring                                  |
| 21.         | 03-1544-08  | Soc. Head Screw                         |
| 22.         | A32900-020  | Breaker (includes 13,14,15,17, 18 & 20) |
| 23.         | A38071-021  | Auger                                   |
| 24.         | A33194-020  | Evaporator                              |
| 25.         | 03-1405-41  | Cap Screw                               |
| 26.         | A32962-001  | Insulation Bot. (half)                  |
|             | A32962-002  | Insulation half                         |
| 27.         | A32050-001  | Drip Pan                                |
| 28.         | 13-0704-00  | Drip Pan Gasket                         |
| 29.         | 13-0868-01  | Water Shed                              |



# NME650 & FME800 SERVICE PARTS

## Control Box

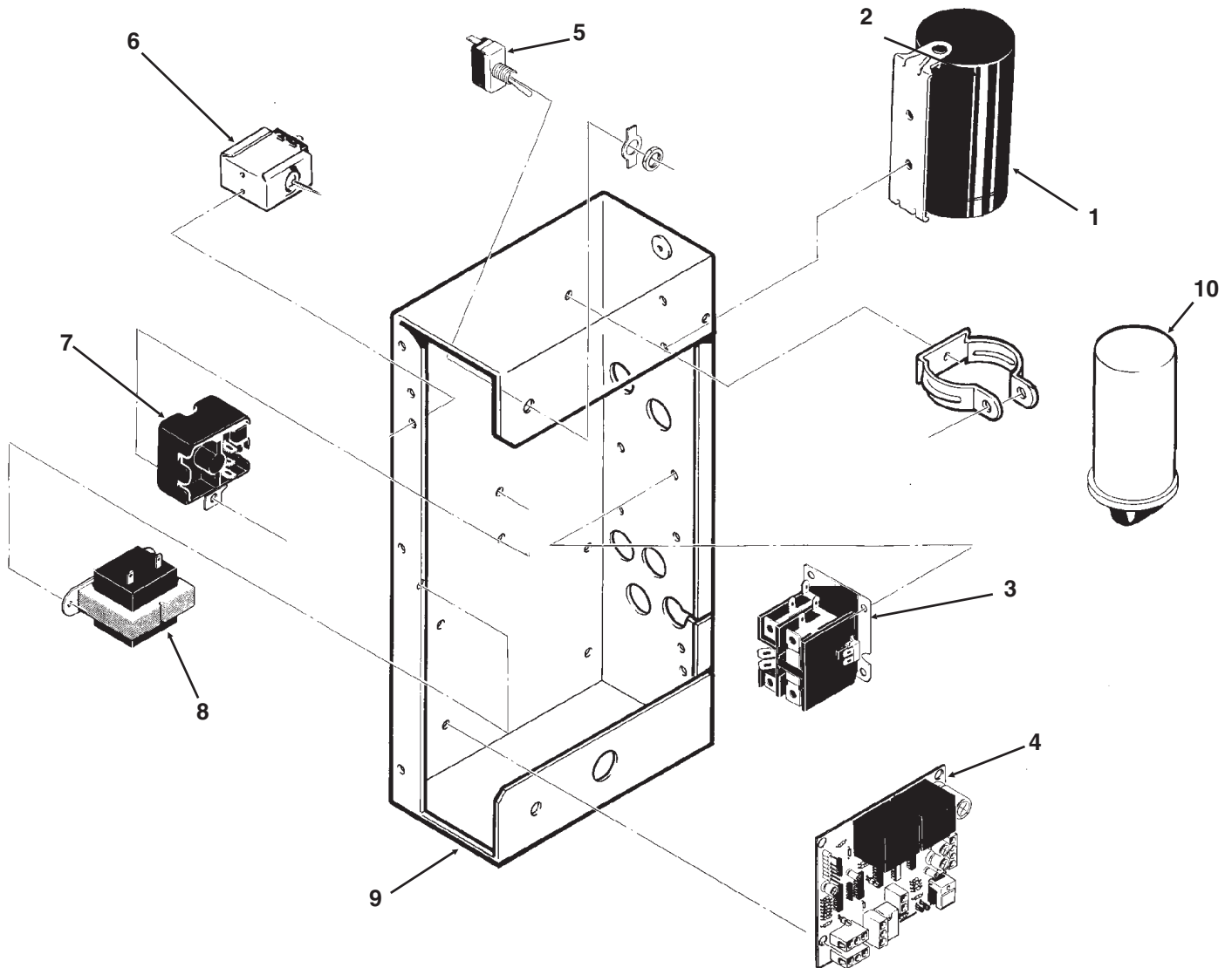

| ITEM NUMBER | PART NUMBER | DESCRIPTION                |
|-------------|-------------|----------------------------|
| 1*          | 18-1901-03  | Start Capacitor 115 v      |
|             | 18-1901-43  | Start Capacitor 230v/50 Hz |
|             | 18-2200-38  | Start Capacitor Cap.       |
| 2.          | 18-2200-39  | Start Capacitor Bracket    |
|             | 03-1638-04  | Screw                      |
|             | 03-1417-24  | Lockwasher                 |
| 3.*         | 12-2469-03  | Contactor 115v/60 Hz       |
|             | 12-2469-02  | Contactor 230v/50 Hz       |

NME-6B or FME800-6B only:  
 12-2649-02 Contactor 230v/50 Hz

4 A37750-021 Circuit Board  
 5. 12-0426-01 Master Switch

NME650 -6B or FME800 - 6B only:  
 12-2637-01 Toggle switch

6. 11-0447-20 Low Pressure Control - all but NME650-6B or FME800-6B

| ITEM NUMBER | PART NUMBER | DESCRIPTION                |
|-------------|-------------|----------------------------|
| 7*          | 18-1903-50  | Potential relay 115 volt   |
|             | 18-1903-56  | Potential relay 230v/50 Hz |
| 8.*         | 12-2285-21  | Transformer 115v/60 Hz     |
|             | 12-2285-22  | Transformer 230v/50 Hz     |

NME650 -6B or FME800 - 6B only:  
 12-2639-01 Transformer

9 no number Control Box  
 10\* 18-1902-45 Run capacitor, 115v/60 Hz  
 18-1902-30 Run capacitor, 230v/50 Hz

NOT ILLUSTRATED  
 11. 12-2337-05 2 Pin Plug Assy (Safety Circuit to Circuit Board)  
 12. 12-2340-01 4 Pin Plug Assy (Transformer to Circuit Board)  
 13. A34055-001 Control Box Cover

NME650 -6B or FME800 - 6B only:  
 14 12-2687-01 Fuse block  
 15 12-2686-02 2A Fuse

\* Match part voltage to machine voltage.

# NME650 & FME800 SERVICE PARTS

## Component Layout Diagram

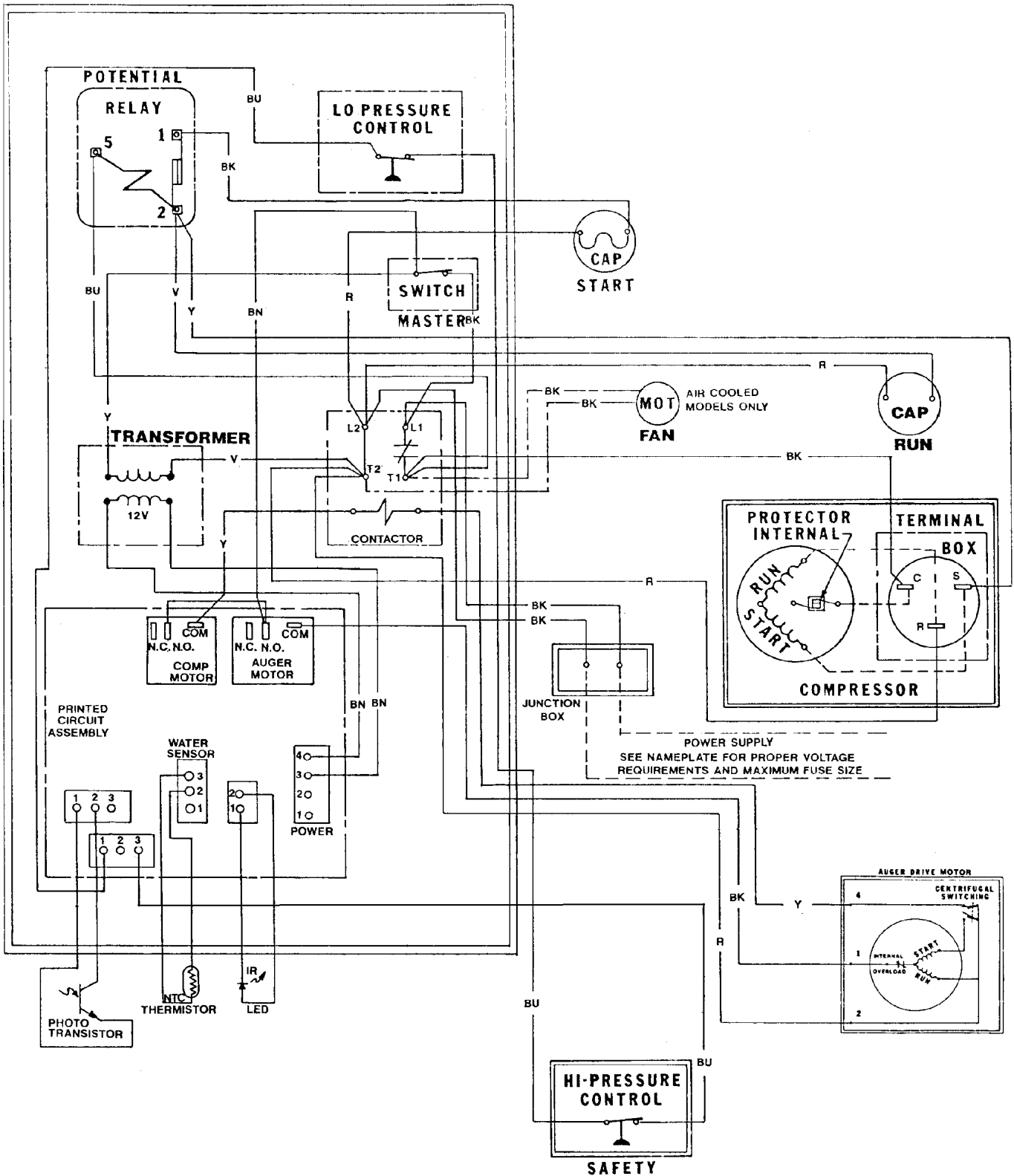

# NME650 & FME800 SERVICE PARTS

## Schematic Diagram

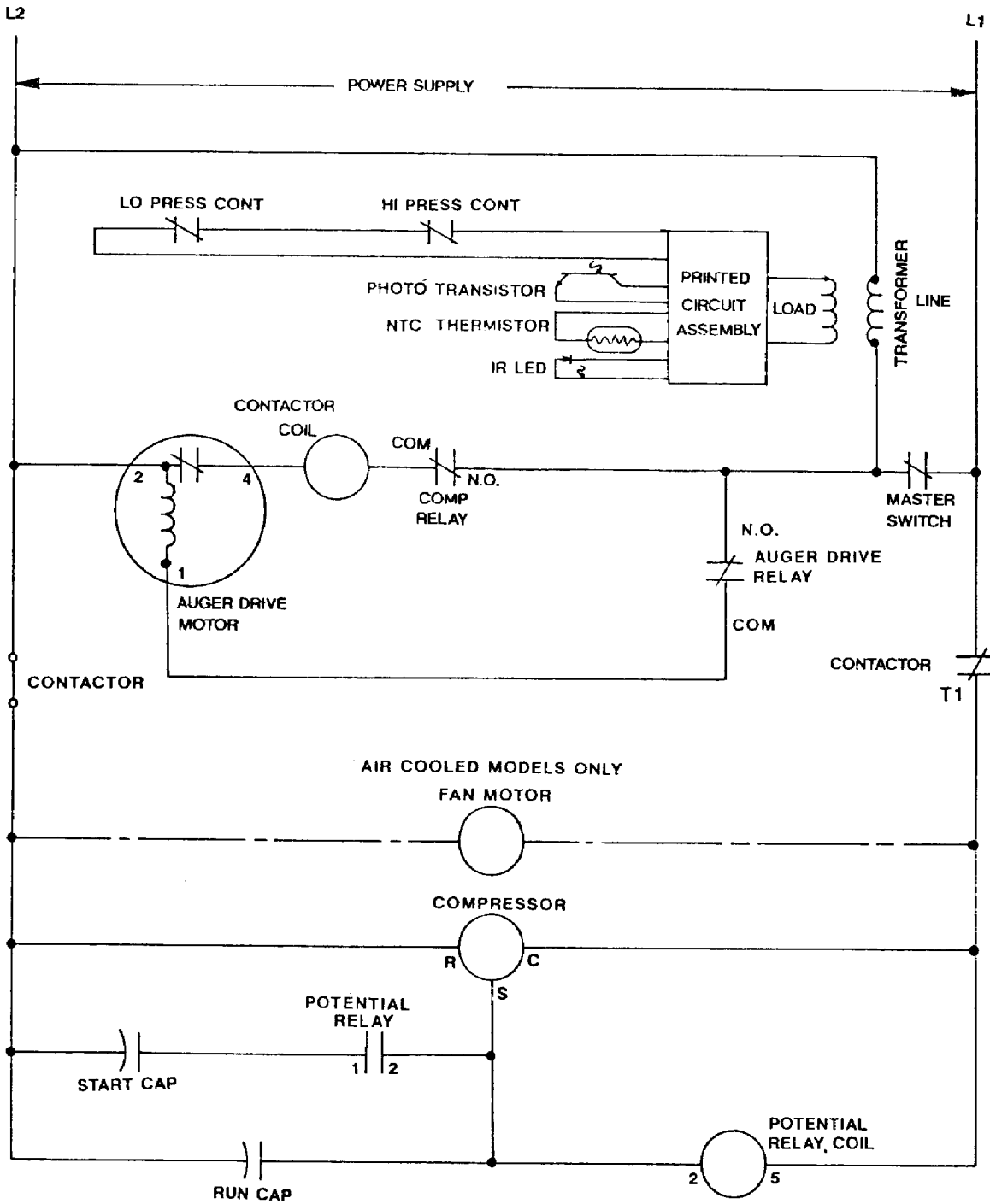

# NME650 & FME800 SERVICE PARTS

## NME650 or FME800 -6B

17-2559-01

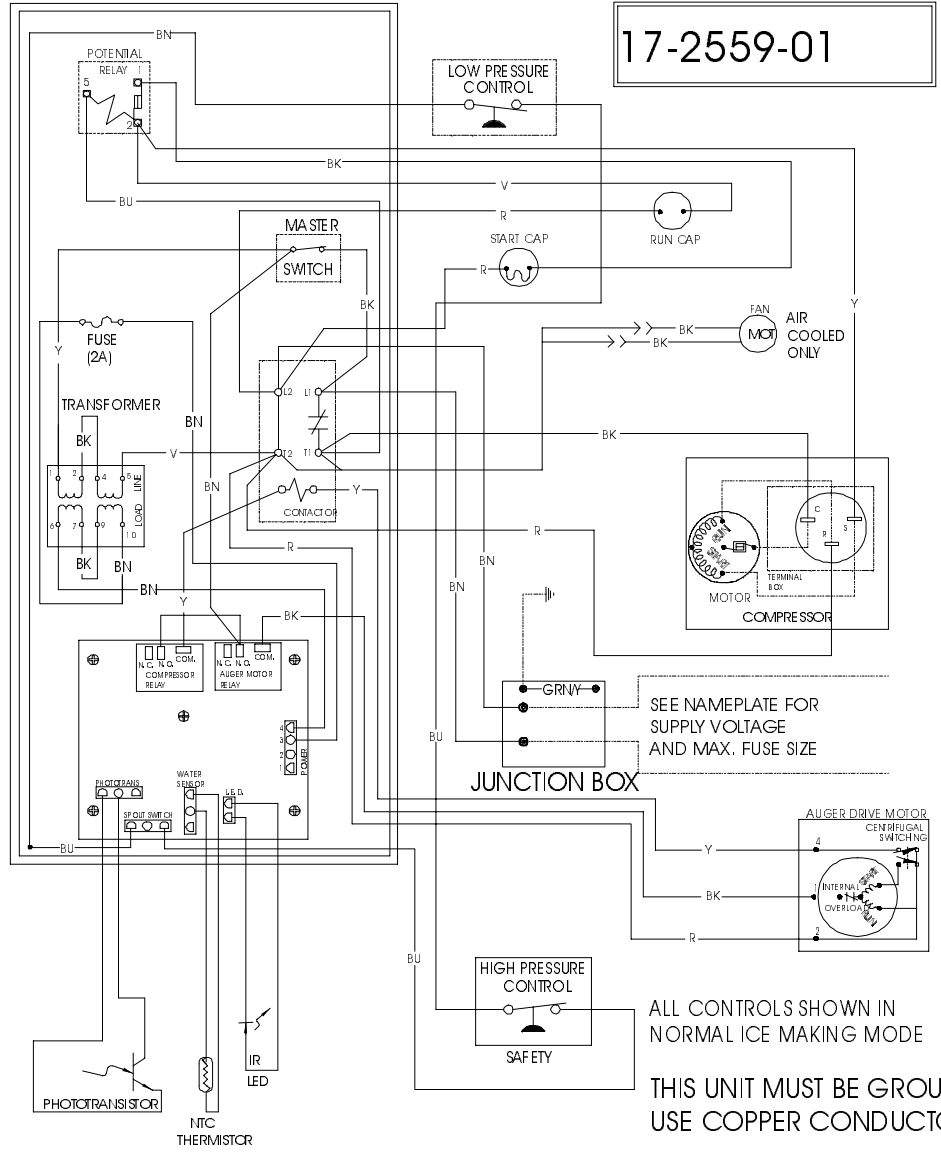

SEE NAMEPLATE FOR  
SUPPLY VOLTAGE  
AND MAX. FUSE SIZE

ALL CONTROLS SHOWN IN  
NORMAL ICE MAKING MODE

THIS UNIT MUST BE GROUNDED  
USE COPPER CONDUCTORS ONLY

