

FMPE-20≤07111017 FMPE-25 FMPE-30≤0711

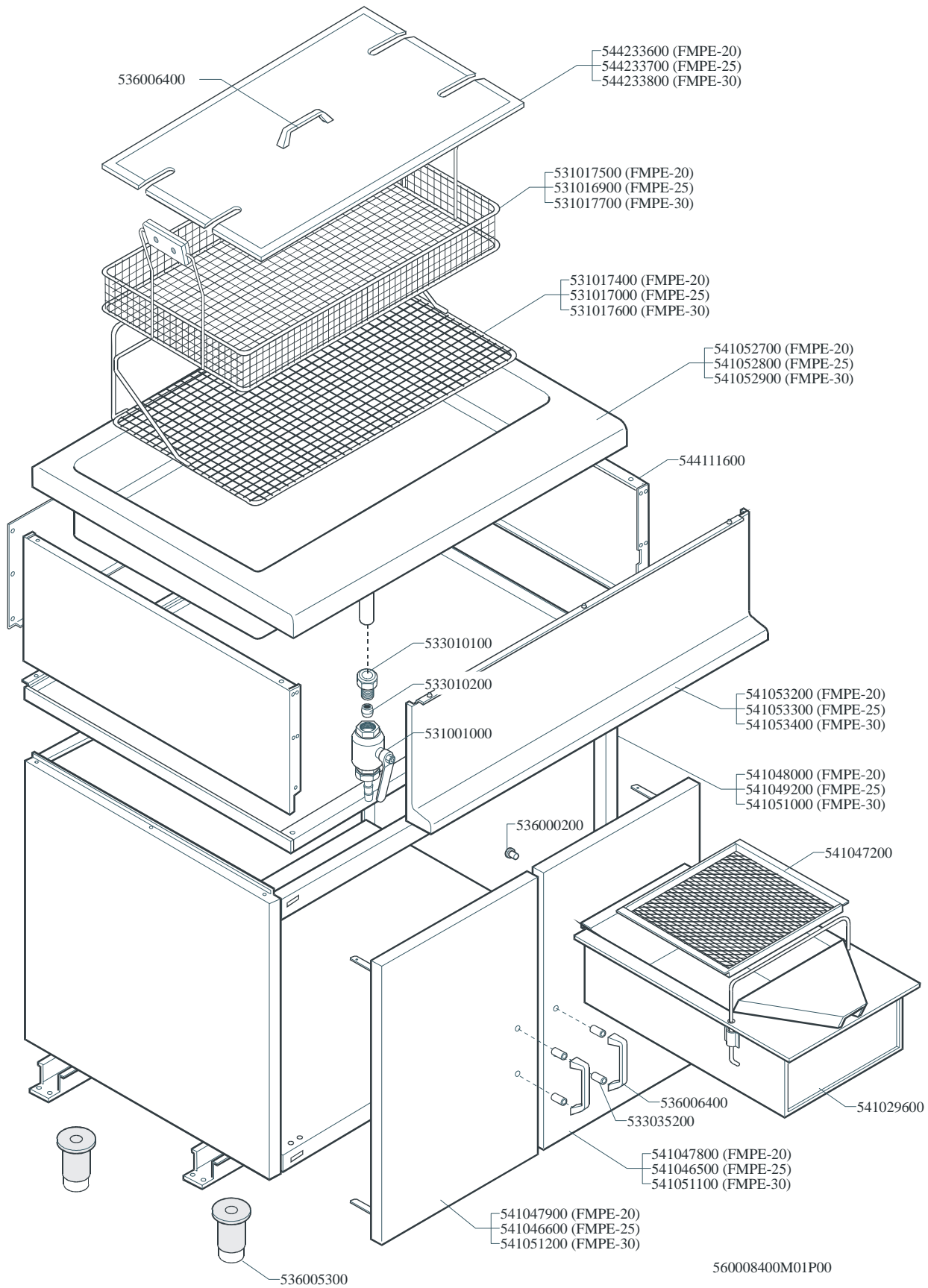

FMPE-20≤07111017 FMPE-25 FMPE-30≤0711

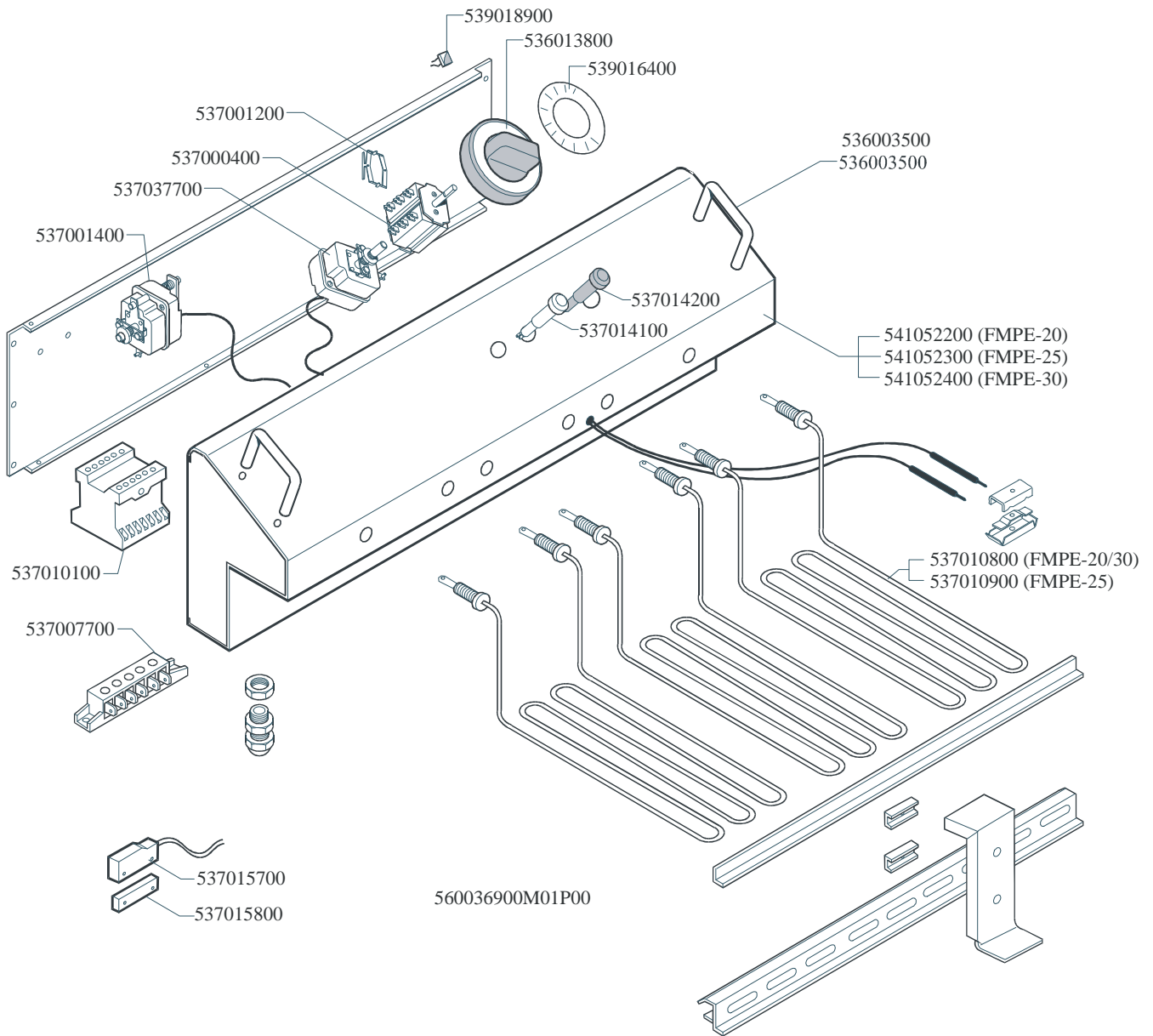

Page	Pos	Code	Description
001		536006400	BLACK HANDLE 65/FE/FG
001		544233800	TANK LID FMPE-30
001		531017700	FRYER BASKET 100 865X350X80H FMPE30
001		531017600	TANK FILTER/BASKET SUPPORT FPE-30
001		541052900	UPPER PLATE FMPE-30
001		544111600	SIDE PANEL 700
001		533010100	3/4 D. 18 PIPE UNION
001		533010200	BICONE 18S
001		531001000	DRAIN COCK 3/4" + HANDLE
001		541053400	CONTROL PANEL FMPE-30
001		541051000	1000 CABINET MP-100
001		541047200	FILTER FOR DRIP TRAY
001		536000200	D.12 H.4 BUMPER
001		541029600	DRIP TRAY 40L
001		533035200	
001		541051100	RIGHT DOOR 50
001		541051200	LEFT DOOR 50
001		536005300	PLASTIC LED 2"
002		539018900	INDEX FOR KNOB
002		536013800	KNOB D.70 BLACK 6*5 WITH SPRING
002		539016400	ADHESIVE GRADUATED DISC FOR KNOB
002		536003500	RED HANDLE 60/SK
002		537001200	FIXING BRACKET FOR THERMOSTAT/COMM.
002		537000400	COMMUTATOR 1POS.SINGLEPHASE S49 16A
002		537037700	THERMOSTAT MONOPHASE 104-192°C
002		537001400	SAFETY THERMOSTAT 235°C THREEPHASE
002		537014200	GREEN WARNING LIGHT 250V
002		537014100	WHITE WARNING LIGHT 250V
002		537010100	REMOTE CONTROL SWITCH 20A 230V
002		537007700	TERMINAL BLOCK THREEPHASE 40A
002		541052400	CONTROL PANEL UNIT FMPE-30
002		537010800	HEATING ELEMENT W1800 V230 FP20/30
002		537015700	MAGNETIC SENSOR (SWITCH)
002		537015800	MAGNETIC UNIT FOR SENSOR