

# CME865W & CME1002W SERVICE PARTS

This parts list contains the parts for the **CME865W** and the **CME1002W**. The model number of the machine is located on the ice machine in two places: on the back panel, and behind the front panel below the control box.

Check the model number to be certain of obtaining the correct parts. Some machines are 50 Hz. They have a "-6" at the end of the model number, such as CME1002WE-6A

**The major differences are in the timer, the compressor and its starting components. The two models also have different Hot Gas Valves.**

## TABLE OF CONTENTS

Cabinet . . . . .	Page 2
Interior Cabinet Components . . . . .	Page 3
Refrigeration System . . . . .	Page 4
Water System . . . . .	Page 5
Control Box . . . . .	Page 6
Ice Storage Bin . . . . .	Page 7
Wiring Diagrams . . . . .	Page 8

# CME865W & CME1002W SERVICE PARTS

## CABINET

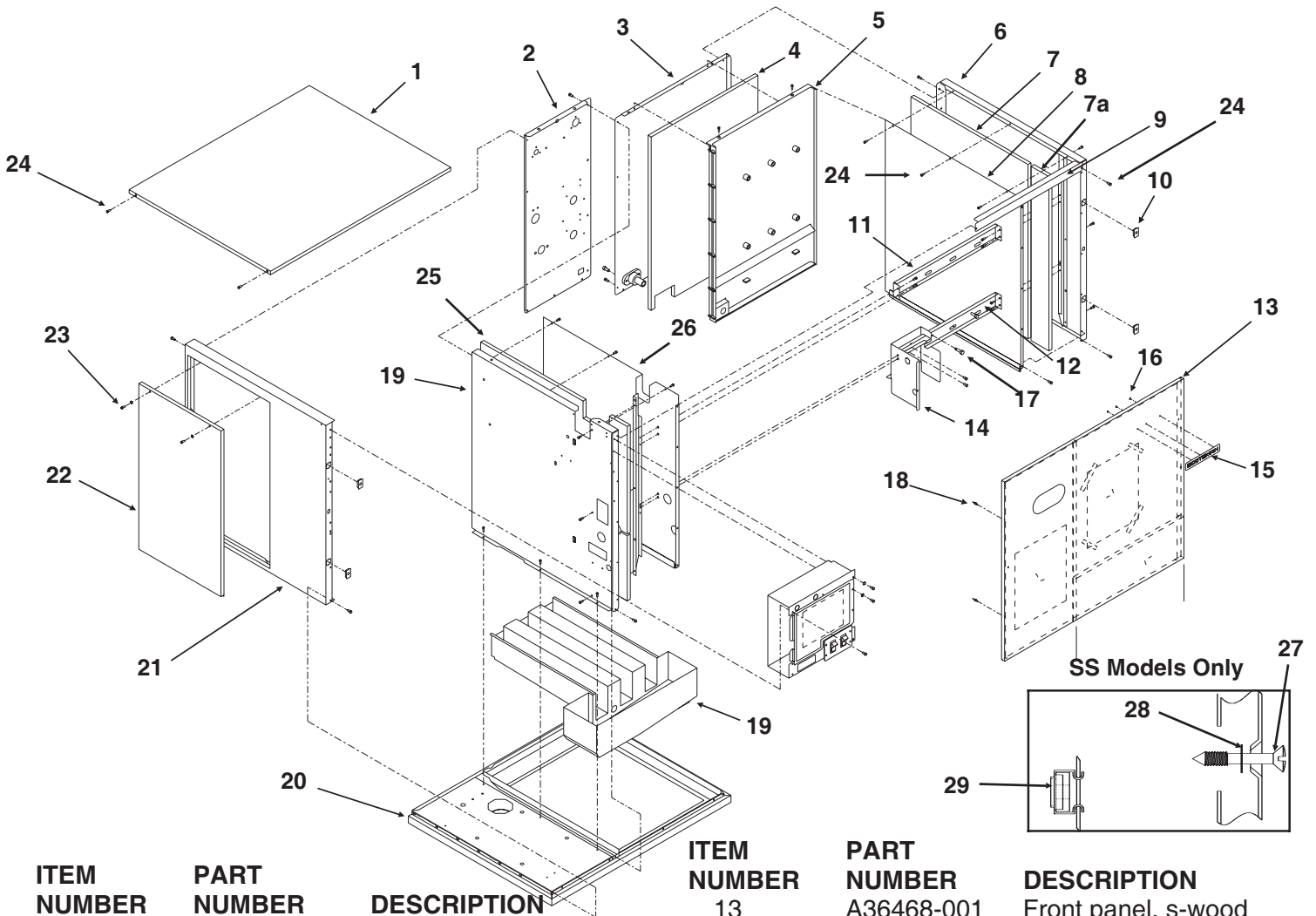

ITEM NUMBER	PART NUMBER	DESCRIPTION	ITEM NUMBER	PART NUMBER	DESCRIPTION
1	A32159-002	Top Panel, SS	13	A36468-001	Front panel, s-wood
	A32159-001	Top Panel, sandalwood		A36468-015	Front panel, gray
2	A32159-015	Top panel, gray	14	A36468-002	Front panel, SS
	A36317-003	Small back panel, s-wood	15	A36308-001	Pump housing
	A36317-015	Small back panel, gray	16	15-0711-01	Emblem for sandalwood
3	A36317-003	Small back panel, SS	17	15-0808-03	Emblem, for SS or gray
	A32452-003	Right back panel, s-wood	18	03-0271-00	Clip for emblem
	A32452-015	Right back panel, gray	19	A32464-001	Stand off for curtain
	A32452-003	Right back panel, SS	20	15-0411-00	Strike
4	A32458-002	Back insulation	21	A35861-001	Reservoir
5	02-2888-01	Back Liner	22	A34861-002	Base Assembly
6	A35453-001	Right side panel, sandalwood		A32435-002	Left Side Panel, SS
	A35453-015	Right side panel, gray		A32435-015	Left side panel, gray
	A35453-002	Right side panel, SS		A32435-001	Left Side Panel, s-wood
7	A32458-004	Right side insulation		A34038-002	Service Panel, SS
7a	A32458-005	Small insulation		A34038-015	Service panel, gray
8	02-2887-01	Right side liner		A34038-001	Service Panel, s-wood
9	A32469-001	Brace	23	03-1404-12	Screw
10	02-0836-00	Catch	24	03-1531-01	Screw
11	A32587-001	Upper Evap. Brace	25	A32458-003	Insulation
12	A32467-002	Lower Evap. Brace	26	02-2885-01	Left side liner
			27	03-1702-01	Screw
			28	03-1702-02	Washer
			29	03-1703-01	Retaining nut

# CME865W & CME1002W SERVICE PARTS

## INTERIOR CABINET COMPONENTS

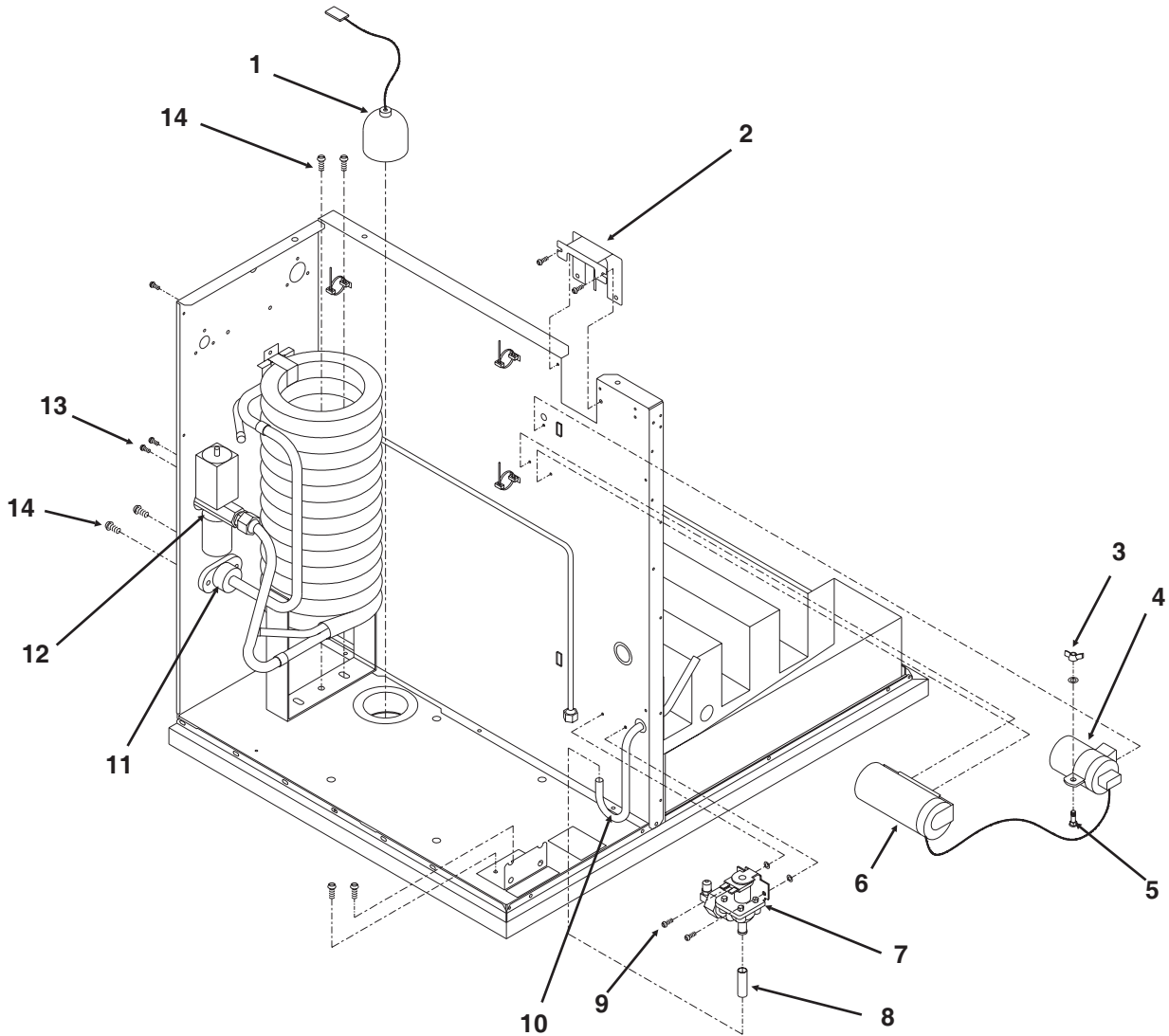

ITEM NUMBER	PART NUMBER	DESCRIPTION	ITEM NUMBER	PART NUMBER	DESCRIPTION
1	A34908-021	Transducer	9	03-1531-01	Screw
2	02-3404-01	Flange retainer	10	A36293-001	Tube
3	03-0255-04	Wing nut	11	A31828-003	Drain adapter
4	18-1902-55	Run capacitor, for all except	12	11-0478-01	Water reg .valve
	18-1902-57	CME1002-6 (50 Hz)	13	03-1645-01	Screw
		Run capacitor for	14	03-1405-15	Screw
		CME1002-6 (50 Hz)			
5	03-1652-02	Bolt			
6	18-1901-48	Start capacitor			
	A35328-001	Capacitor cover			
7	12-2446-26	Inlet water valve			
8	13-0674-02	Tubing, 1.5" req.			

# CME865W & CME1002W SERVICE PARTS

## REFRIGERATION SYSTEM

ITEM NUMBER	PART NUMBER	DESCRIPTION	ITEM NUMBER	PART NUMBER	DESCRIPTION
1	16-0876-01	Distributor and tubes	11	03-1405-20	Screw
2	16-0875-01	Suction line header	12	18-8749-22	Compressor* for CME865 60 Hz
3	16-0878-21	TXV for 60 Hz models	18-8749-27	Compressor* for CME865 50 Hz	
	16-1022-21	TXV for 50 Hz models	18-8750-22	Compressor* for CME1002 60 Hz, single phase	
4	02-3396-01	Insulation for TXV (half)	18-8750-24	Compressor* for CME1002 60 Hz, 3 phase	
5	A30296-020	Evaporator	18-8750-27	Compressor* for CME1002 50 Hz	
6	16-0877-01	Hot gas manifold	Replacement compressors include a crankcase heater, not used on this model. It may be disconnected or used upon installation.		
7	11-0493-21	Hot gas valve for CME865			
	11-0491-21	Hot gas valve for CME1002	13	12-2300-07	Hi temp cut out
8	11-0486-21	Hi pressure control switch	14	02-3319-02	Filter drier
9	16-0832-20	Access valve	15	11-0478-01	Water reg. valve
	16-0832-03	Port/core cap	16	16-0874-01	Receiver
	16-0832-02	Stem cap	17	18-8200-25	Water cooled condenser
10	18-2200-27	Sleeve			
	18-2200-28	Grommet			

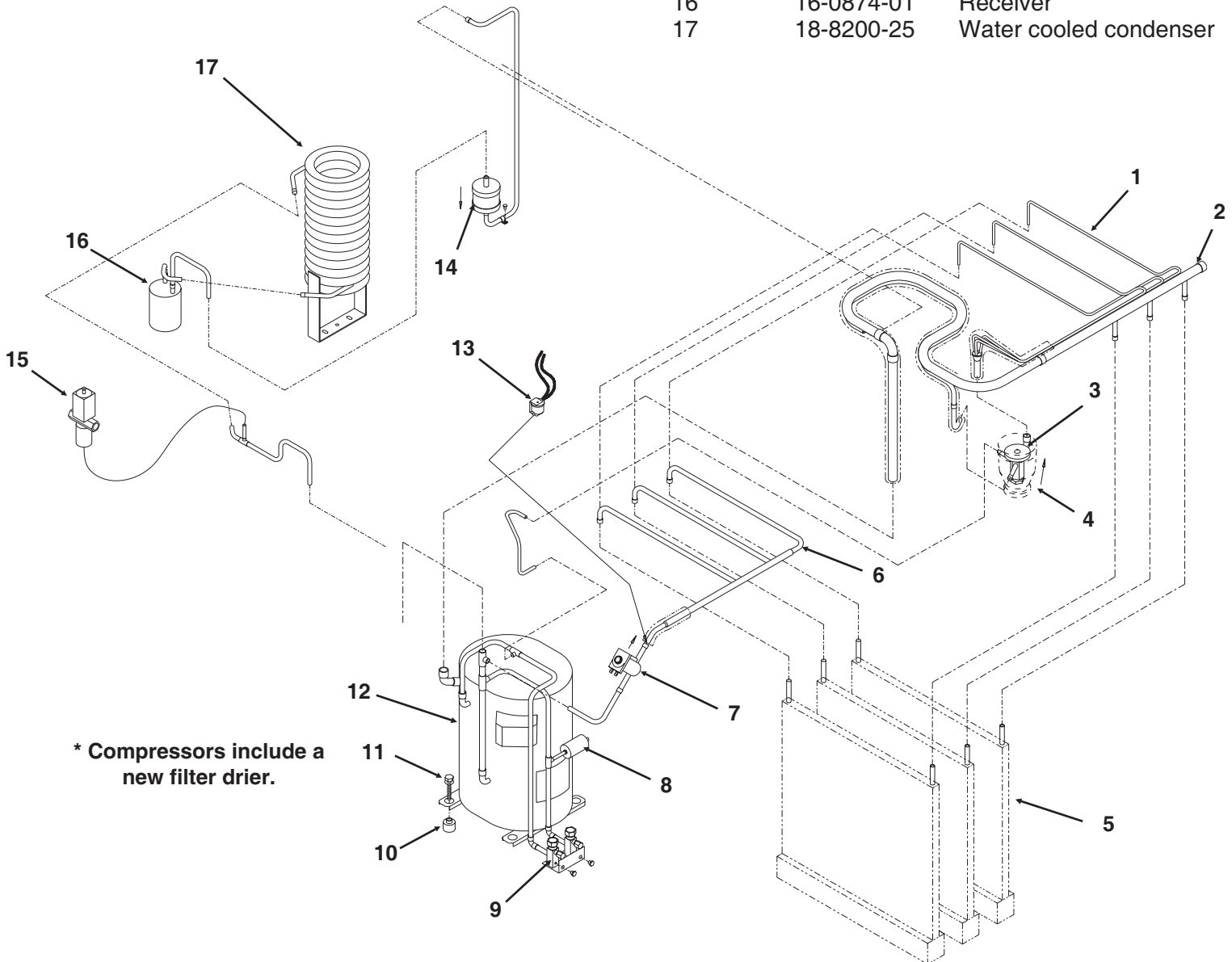

\* Compressors include a new filter drier.

# CME865W & CME1002W SERVICE PARTS

## WATER SYSTEM

ITEM NUMBER	PART NUMBER	DESCRIPTION	ITEM NUMBER	PART NUMBER	DESCRIPTION
1	02-2527-01	Water Distributor Tube	15	03-1403-27	Screw
2	02-2521-01	Water Manifold, long	16	A34982-001	Drain fitting
3	13-0617-48	O-Ring	17	13-0796-01	Reservoir Drain Cap
4	A29703-001	Water Manifold, short	18	02-3094-01	Hose clamp
5	02-2895-01	Water Restrictor	19	13-0674-07	Drain hose (16.5" needed)
6	13-0674-07	Tube (need 30")	20	02-2606-01	Drain tube
7	02-3094-01	Hose clamp	21	13-0617-02	O-ring
8	02-2878-01	End cover			
9	02-2890-03	Evaporator Cover			
10	A35861-001	Reservoir			
11	03-1404-10	Screw			
12	13-0674-02	Hose (12" needed)			
13	12-2419-62	Water Pump			
14	A36308-001	Housing, pump			

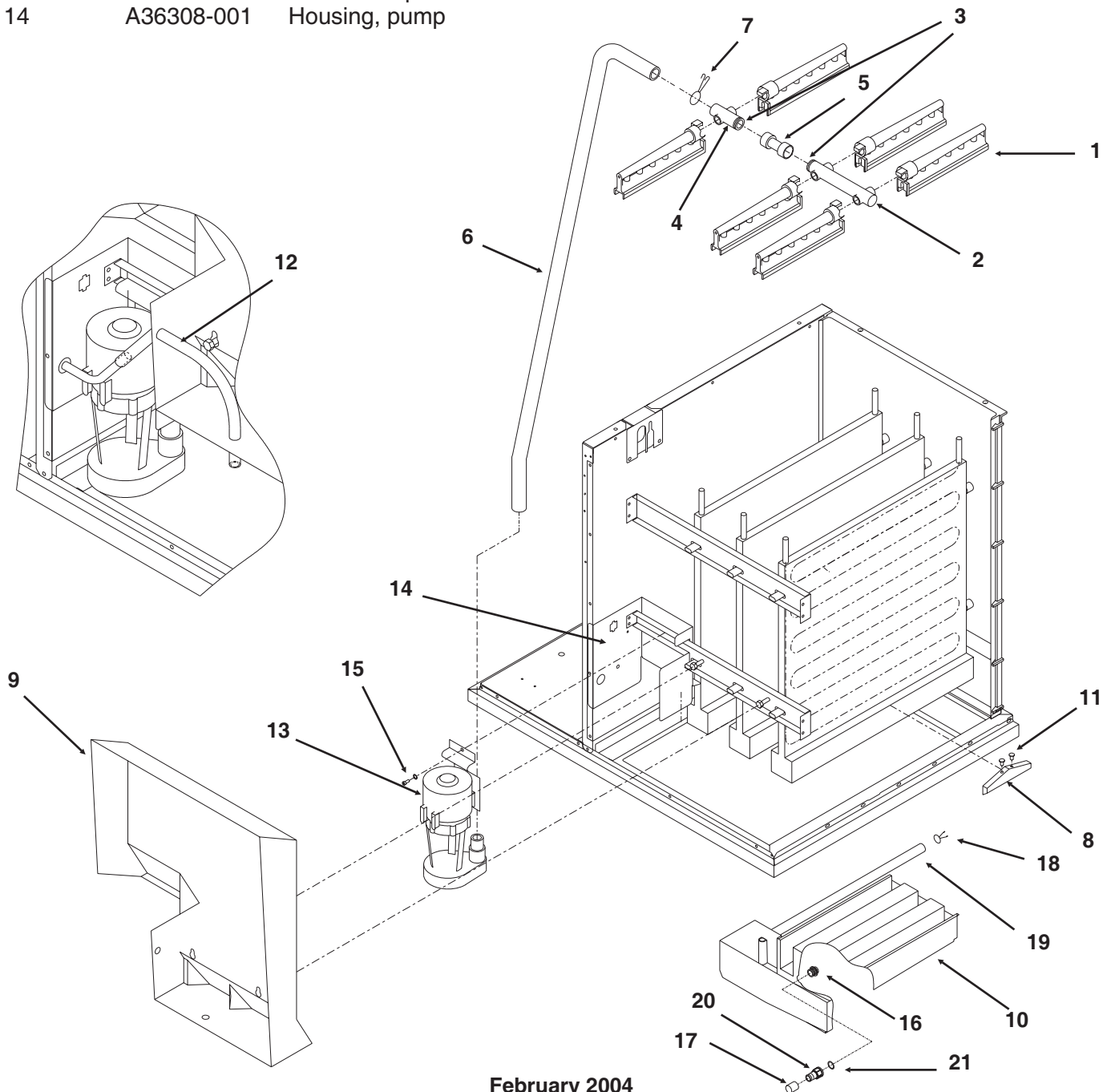

# CME865W & CME1002W SERVICE PARTS

## CONTROL BOX

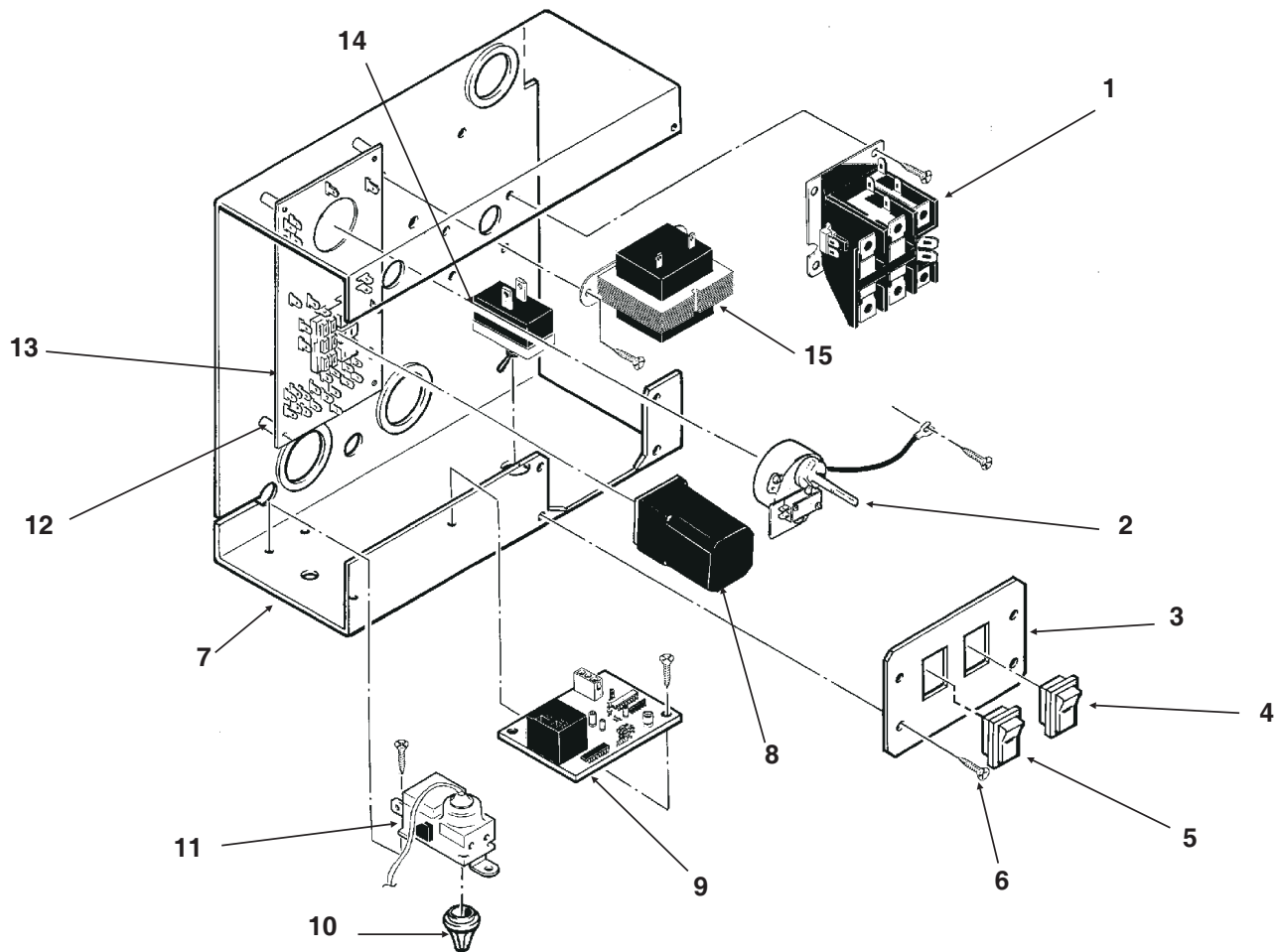

ITEM NUMBER	PART NUMBER	DESCRIPTION	ITEM NUMBER	PART NUMBER	DESCRIPTION
1	12-0739-02	Contactors 3 phase	13	12-1912-01	Circuit board
	12-2469-02	Contactors, single phase	14	12-0426-01	Compressor on off switch
2	12-2107-22	Timer for 60 Hz	15	12-2285-22	Transformer
	12-2107-26	Timer for 50 Hz			
3	02-3173-01	Cover plate	<b>Not Shown</b>		
4	12-2414-01	ON/OFF/WASH switch	16	A34845-015	Control Box Cover
	12-2402-01	Wire harness, bin level switch to board	18	18-1903-46	Potential relay, 60 Hz and CME1002 50 Hz
5	12-2411-01	Bin ice level switch		18-1903-33	Potential relay, for CME865 50 Hz
6	03-1638-03	Screw			
7	no number	Control box			
8	12-1879-03	Relay			
9	12-2376-21	Bin level control board			
10	no number	Knob, part of item 11			
11	11-0436-21	Cube size control, includes knob			
12	02-2242-02	Stand off			

# CME865W & CME1002W SERVICE PARTS

## ICE STORAGE BIN SERVICE PARTS

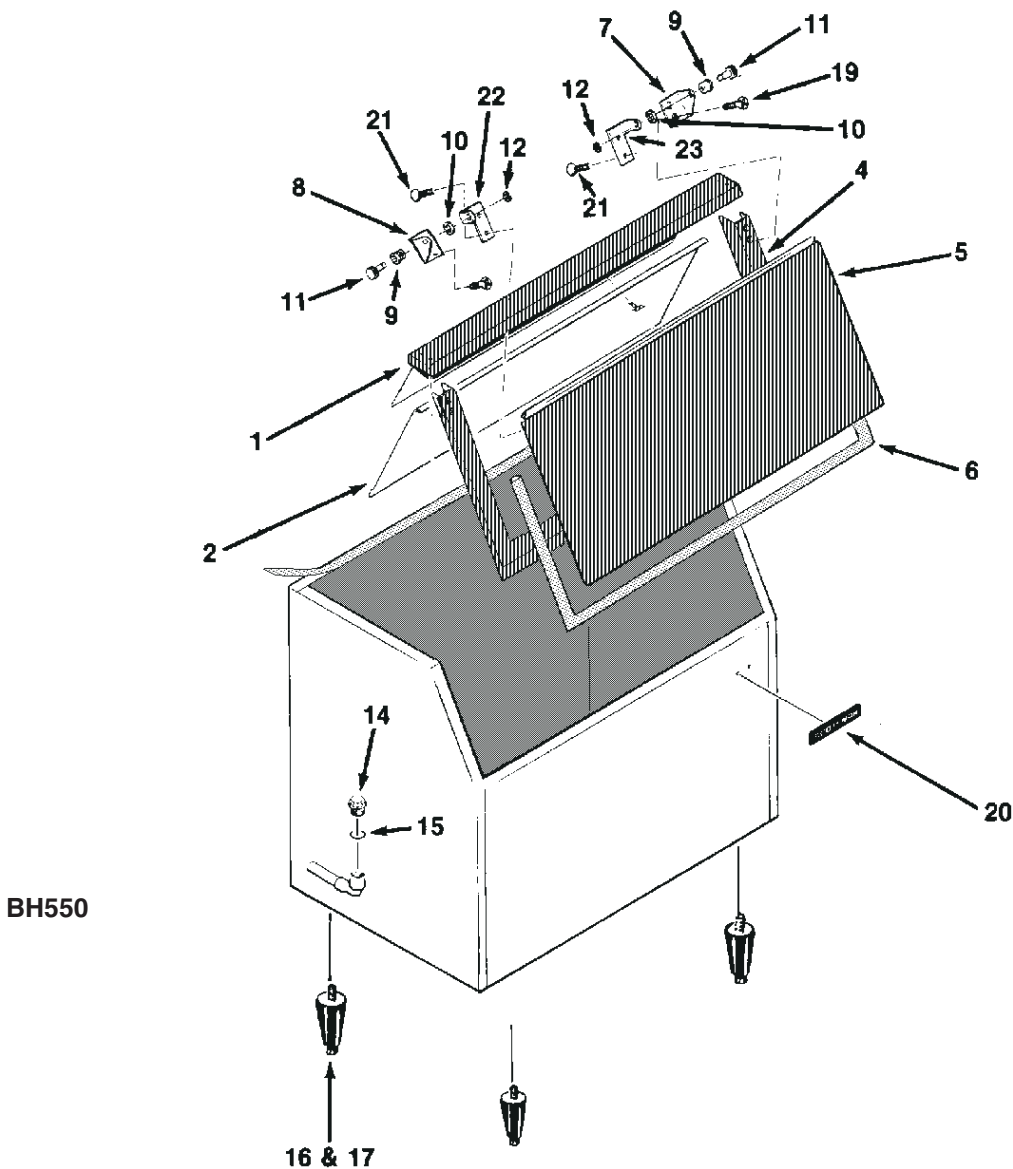

ITEM NUMBER	PART NUMBER	DESCRIPTION	ITEM NUMBER	PART NUMBER	DESCRIPTION
1	A33921-001	Canopy	14	02-2809-01	Drain Top
2	A32580-001	Baffle	15	13-0617-11	O-Ring
3	19-0503-04	Gasket	16	KLPE	Leg kit, black
4	A33922-020	Door Frame	17	KLPS	Leg kit, nickel
5	A37639-021	Door frame for C series	18	03-1404-06	Screw
6	A33938-020	Door	19	03-1360-02	Screw
7	13-0595-00	Door Gasket, 6' req.	20	15-0711-01	Emblem
8	A32396-002	Hinge Right	21	03-1418-41	Screw
9	A32396-001	Hinge Left	22	A32546-001	Door hinge left
10	02-2380-02	Hinge Bushing	23	A32546-002	Door hinge right
11	02-2380-02	Hinge Spacer	24	03-1423-07	Speed nut for baffle
12	02-2806-01	Shoulder Screw			
13	03-1539-09	E-Clip			
	03-0727-06	Thumb Screw			

# CME865W & CME1002W SERVICE PARTS

## Single Phase, 60 Hz Wiring Diagram

Note 2\*: Wire Color for -32 (60 hz) units is Black.  
Wire Color for -6 (50 Hz) units is Brown.

See nameplate for power requirements.

A36450-001

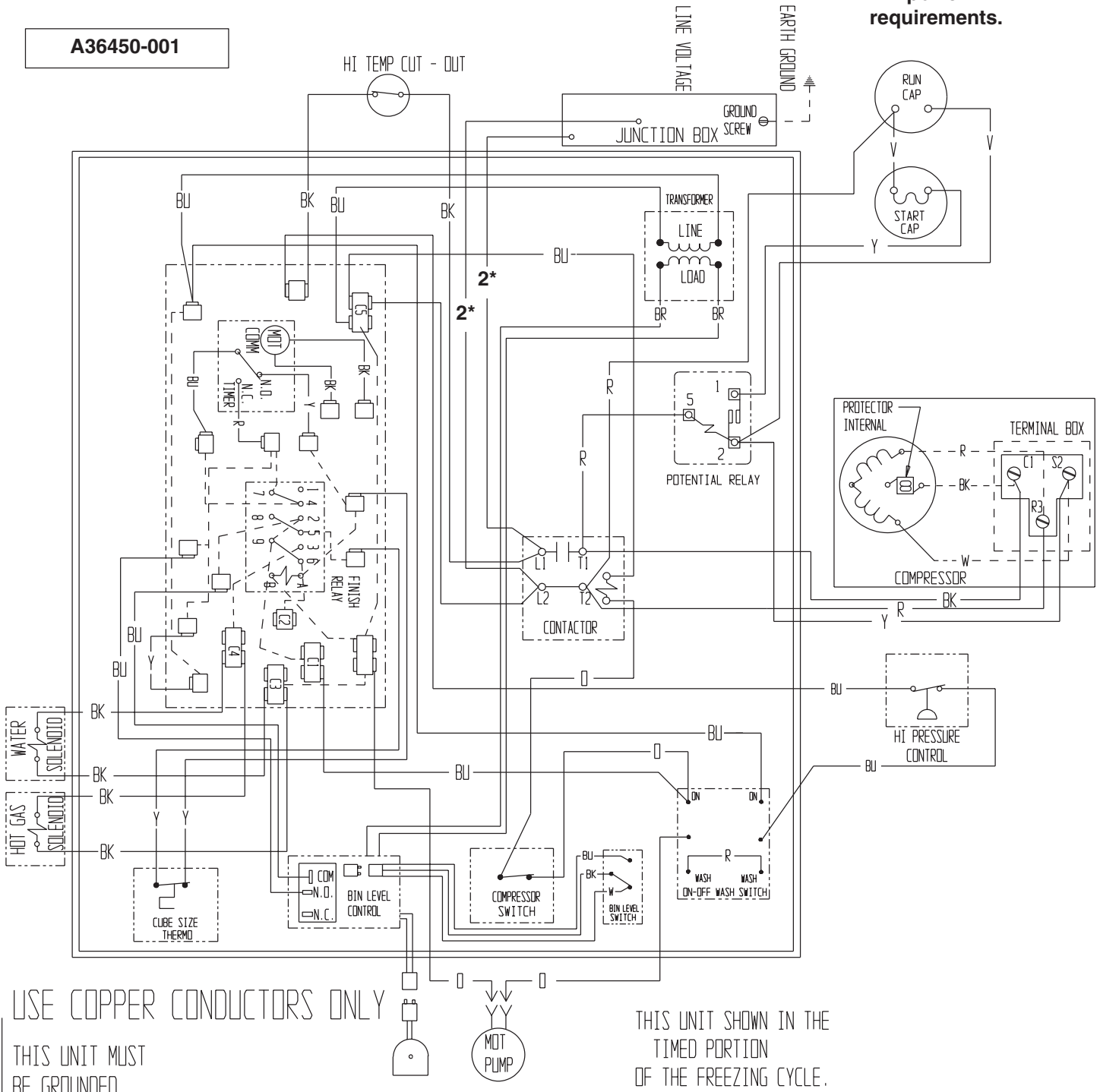

USE COPPER CONDUCTORS ONLY  
THIS UNIT MUST BE GROUNDED.

THIS UNIT SHOWN IN THE  
TIMED PORTION  
OF THE FREEZING CYCLE.



# CME865W & CME1002W SERVICE PARTS

## Single Phase, 60 Hz Schematic Diagram

CAUTION:

MORE THAN ONE DISCONNECT MEANS MAY BE REQUIRED TO DISCONNECT ALL POWER TO THIS UNIT.

⚠ NOTE: DASHED LINES INDICATE FIELD WIRING WHICH MUST BE INSTALLED IN ACCORDANCE WITH THE NATIONAL ELECTRICAL CODE AND ALL STATE AND LOCAL CODES.

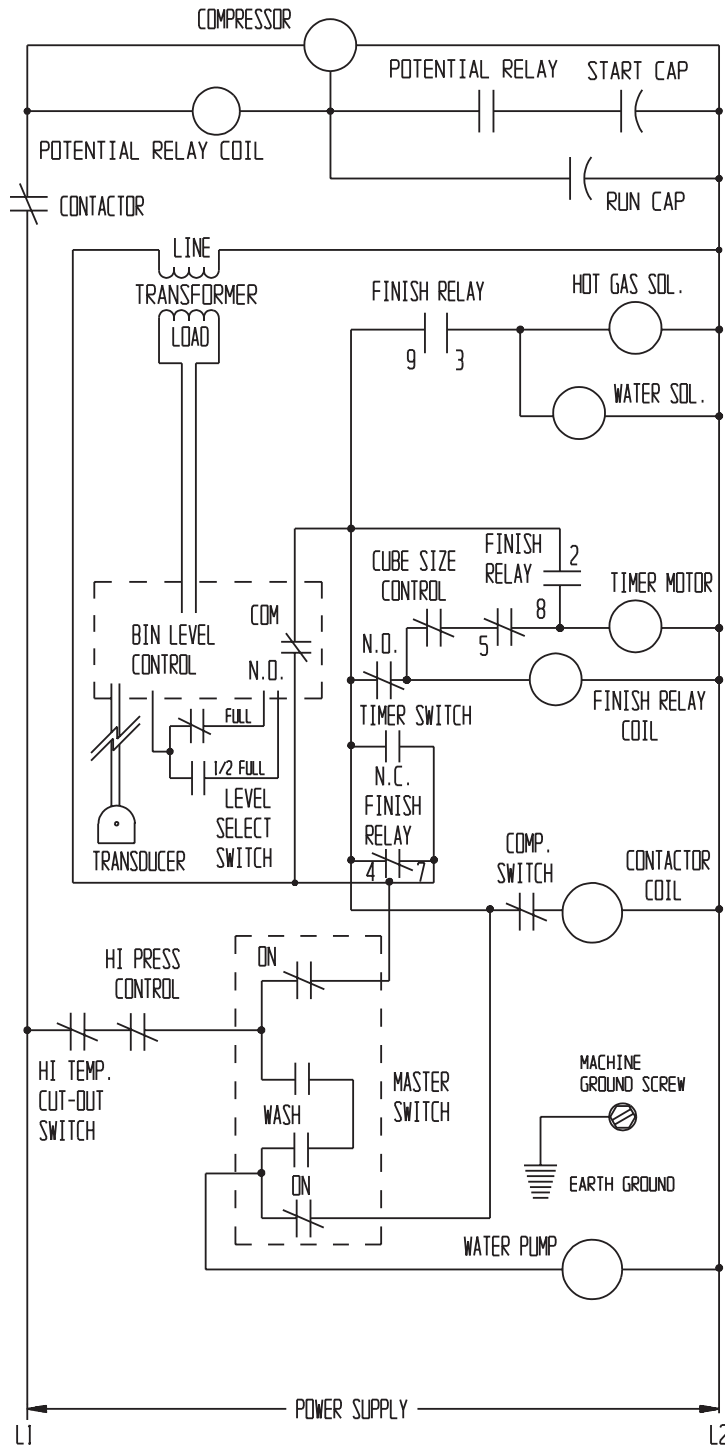

# CME865W & CME1002W SERVICE PARTS

## Three Phase Wiring Diagram

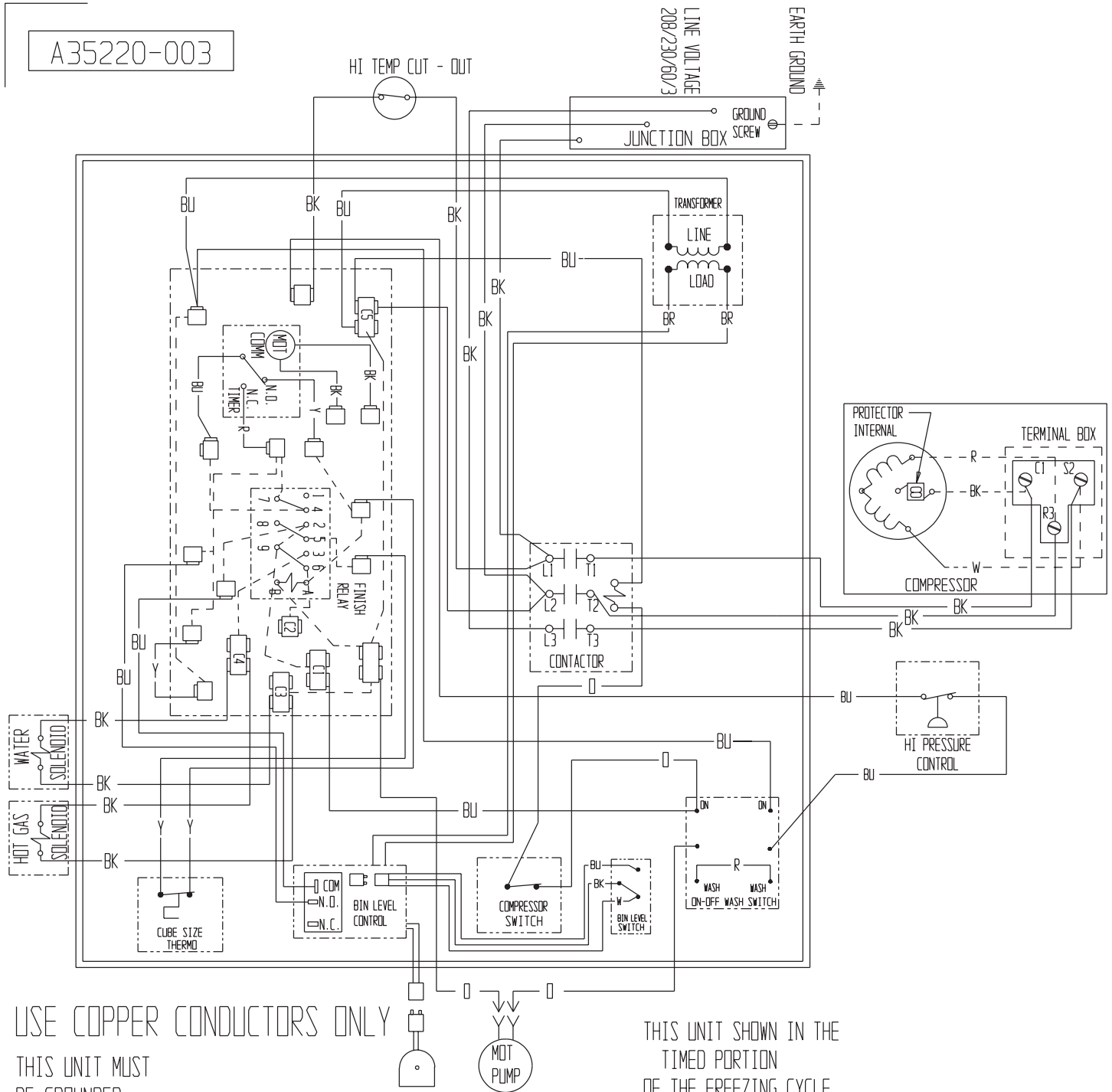

# CME865W & CME1002W SERVICE PARTS

## Three Phase Schematic Diagram

### CAUTION:

MORE THAN ONE DISCONNECT MEANS MAY BE REQUIRED TO DISCONNECT ALL POWER TO THIS UNIT.

NOTE: DASHED LINES INDICATE FIELD WIRING WHICH MUST BE INSTALLED IN ACCORDANCE WITH THE NATIONAL ELECTRICAL CODE AND ALL STATE AND LOCAL CODES.

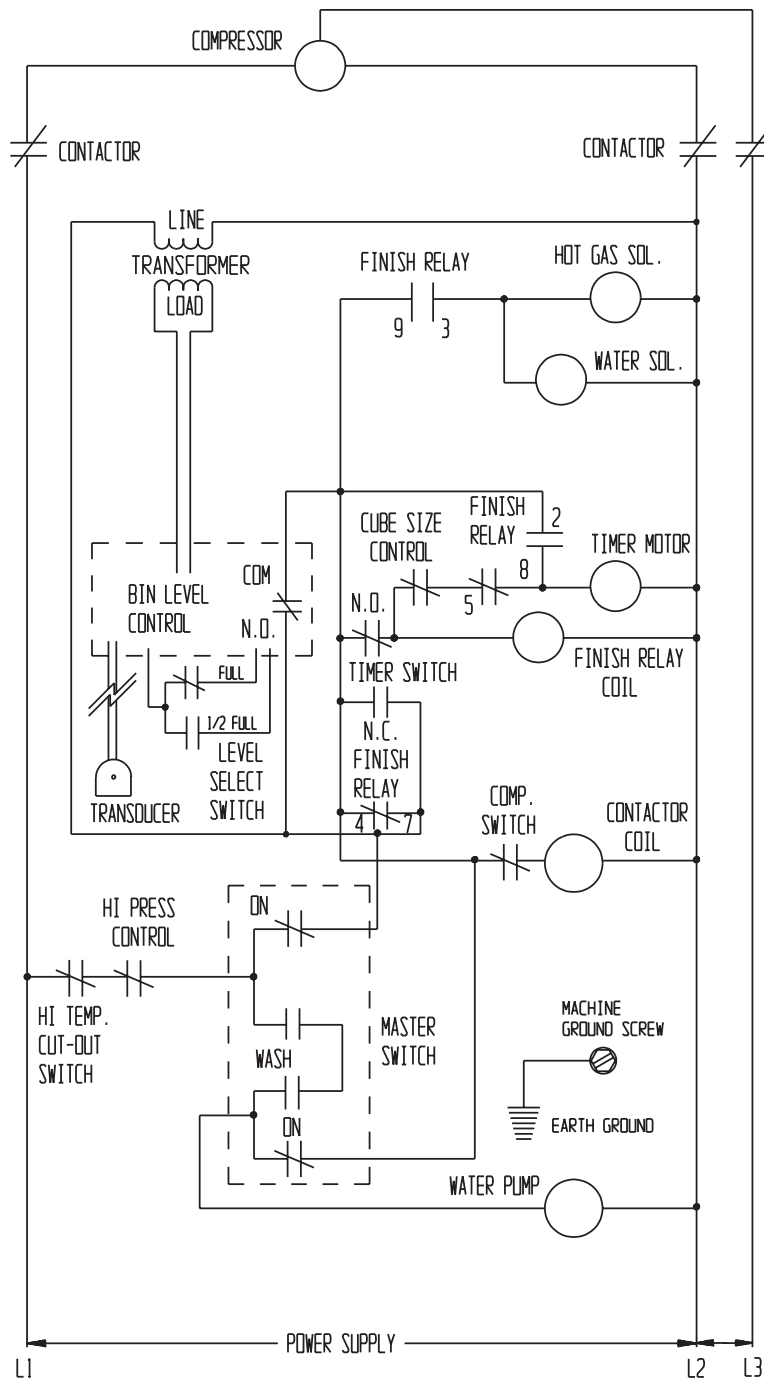

# CME865W & CME1002W SERVICE PARTS

## 50 Hz Wiring Diagram

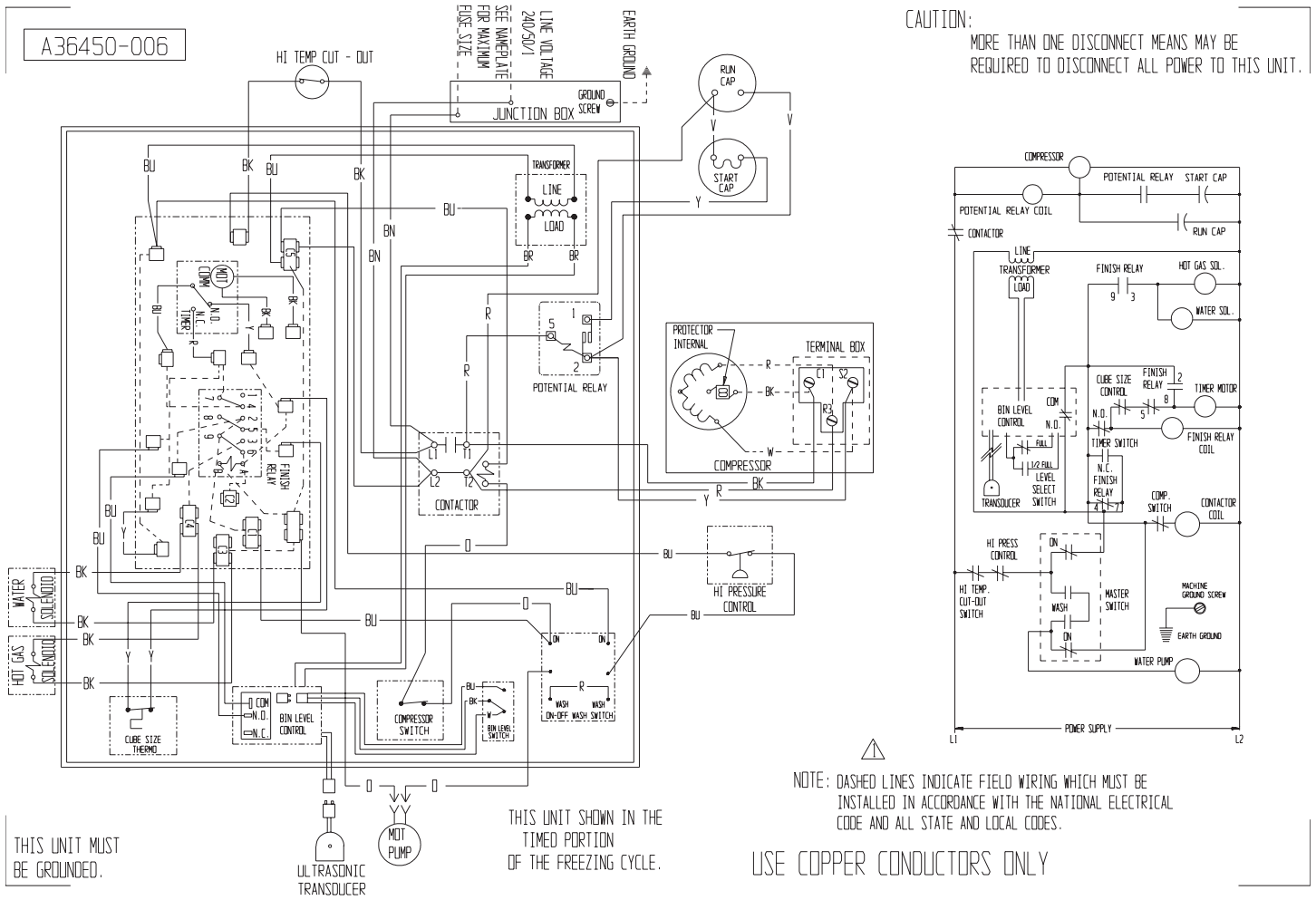

THIS UNIT MUST BE GROUNDED.

ULTRASONIC TRANSDUCER

THIS UNIT SHOWN IN THE TIMED PORTION OF THE FREEZING CYCLE.

NOTE: DASHED LINES INDICATE FIELD WIRING WHICH MUST BE INSTALLED IN ACCORDANCE WITH THE NATIONAL ELECTRICAL CODE AND ALL STATE AND LOCAL CODES.

USE COPPER CONDUCTORS ONLY