

TAV.57		Meccanismo di ribalt.	Mécanisme de bascul.	Tiping mechanisme	Kippmechanismus	GBR	GBRA	EBR	EBRA
	Codice	Denominazione	Denominaton	Denominaton	Bezeichnung				
1	RTBF900104	Supporto oscillante	Support oscillant	Oscillating support	Gelenklager	x	x	x	x
2	RTBF900106	Ribaltatore	Basculeur bac	Tank tilting device	Wannendippvorrichtung	x	x	x	x
3	RTBF900110	Leva ribaltatore	Rallonge basculeur	Filting device extension	Kippvorrichtungsverlängerung	x	x	x	x
4	RTBF900096	Perno fissaggio ribaltatore	Prise basculeur	Filting device plug	Kippvorrichtungsstift	x	x	x	x
5	RTMIN00123	Seeger esterno Ø 10	Seeger Ø 10	Seeger Ø 10	Seeger Ø 10	x	x	x	x
6	RTBF900102	Perno fissaggio riduttore	Tourillon fixation réducteur	Reduction attachment pin	Kippvorrichtung	x	x	x	x
7	RTBF900109	Riduttore	Réducteur	Reduction unit	Untersetzungsgetriebe	x	x	x	x
8	RTMIN00226	Chiavetta 8x7x40	Clavette 8x7x40	Key 8x7x40	Feder 8x7x40	x	x	x	x
9	RTBF800093	Volantino comando ribaltamento	Volant	Handwal	Handwel	x		x	
10	RTBF900105	Bussola prolunga volantino	Fourreau rollonge volant	Flywheel extension bushing	Handradverlängerungsbuchse	x		x	
11	RTMIN00250	Chiavette 6x6x39	Clavette 6x6x39	Key 6x6x39	Feder 6x6x39		x		x
12	RTBF900124	Puleggia riduttore	Poulie réducteur	Reduction unit pulley	Riemenscheibe		x		x
13	GABF900121	Maniglia di soccorso	Poignée de secours	Emergency handle	Not-Griff		x		x
14	RTBF900125	Cinghia trapezoidale	Courroi trapézoïdale	"V"belt	Keilriemen		x		x
15	RTMIN00251	Chiavetta 5x5x25	Clavett 5x5x25	Key 5x5x25	Feder 5x5x25		x		x
16	RTBF900123	Puleggia motore	Poulie moteur	Motor pulley	Motor-Riemenscheibe		x		x
17	RTCU800156	Condensatore	Protection moteur	Motor guard	Motorschutz		x		x
18	RTBF900122	Motore elettrico	Moteur relevage bac	Tank tilting motor	Wannenhebemotor		x		x
19	RTBF800123	Pulsante	Bouton	Pus botton	Druckknopf		x		x
20	PABF900346	Squadretta fissaggio pulsanti	Egierre fixation boutons	Bracket for push botton	Winkleisen		x		x
21	RTBF800125	Contatti pulsanti	Contacts boutons	Pushbotton contact	Druckknopfkontakte		x		x
22	PABF900347	Protezione pulsanti	Protection boutons poussoirs	Pushbotton guard	Schutzvorrichtung		x		x
23	PABF900353	Flangia fissaggio puleggia	Bride fixation poulie	Pulley attachment flange	Befestigungsflansch für Riemenscheibe		x		x

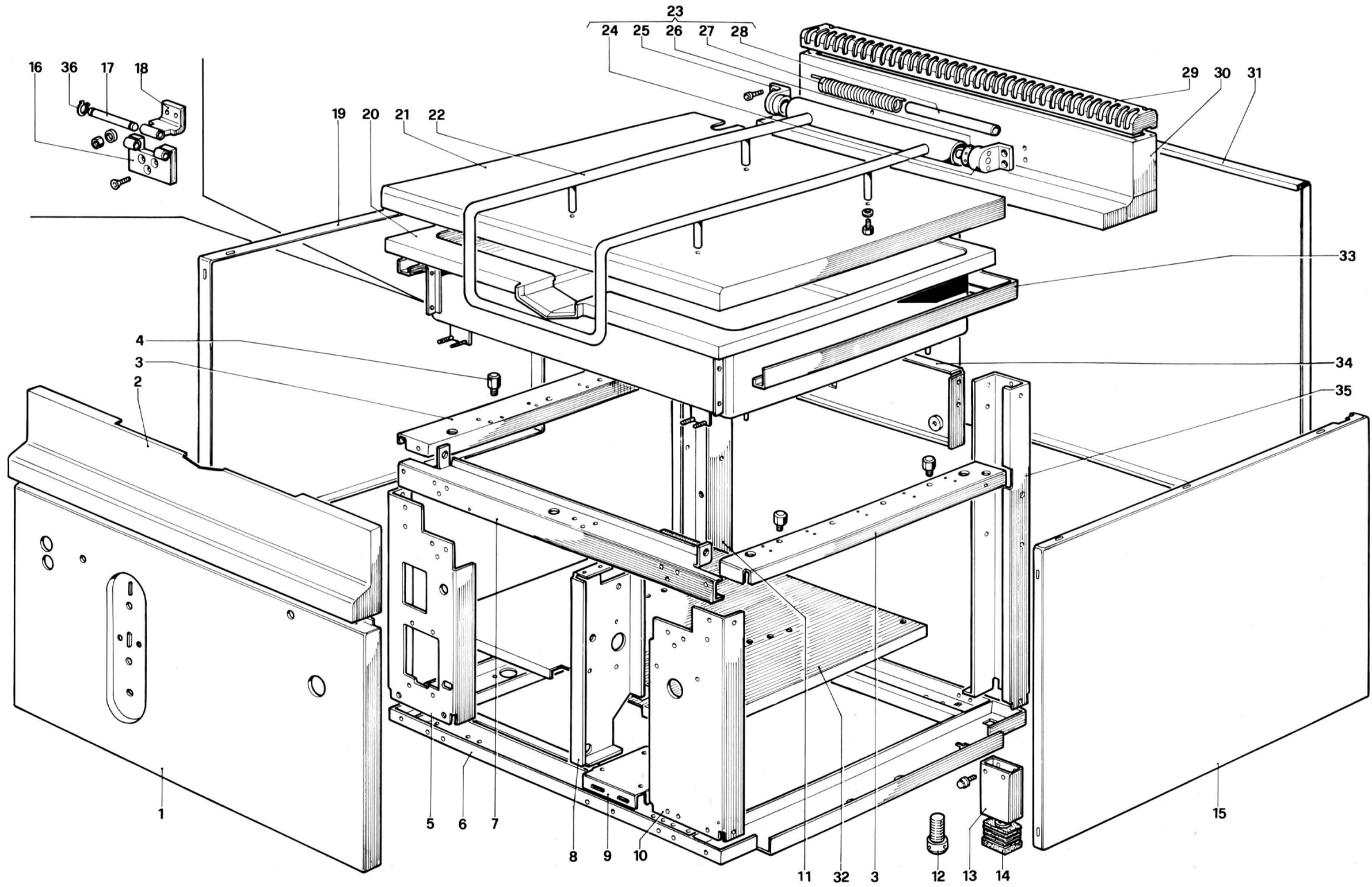

TAV. 58		STRUTTURA	STRUCTURE	STRUCTURE	STRUKTUR	EBR	EBRA
	Codice	Denominazione	Denominaton	Denominaton	Bezeichnung		
1	PABF800293	Facciata esterna	Devanture externe	External face	Aussenvorderwand	×	
1	PABF800294	Facciata esterna	Devanture externe	External face	Stimbrett		×
2	GABF800110	Cruscotto	Panneau de commande	Control panel	Stimbrett	×	×
3	PABF900228	Traversa laterale	Croisillon latéral	Side crossbar	Querträger	×	×
4	RTBF900119	Vite appoggio vasca	Support cuve	Tanke support	Reglerhalterung	×	×
5	PABF900226	Piantana anteriore sinistra	Colonne avant gauche	Front left support	Säule vorne links	×	×
6	GABF800108	Basamento	Soubassement	Base	Untergestell	×	×
7	PABF900247	Traversa anteriore	Croisillon antérieur	Back crossbar	Vorderer Querträger	×	×
8	PABF900220	Supporto centrale perno	Support central	Central support	Mittlere Halterung	×	×
9	PABF800290	Supporto motore	Support moteur	Motor support	Halterung		×
10	PABF900225	Piantana anteriore destra	Colonne avant droite	Front right support	Säule vorne rechts	×	×
11	PABF900331	Piantana posteriore sinistra	Colonne arrière gauche	Rear left support	Säule hinten links	×	×
12	RTCU800022	Regolatore piedino	Regulateur du pied	Foot regulator	Fußregler	×	×
13	GACU800122	Piedino inox	Pied inox	Stainless steel foot	Inox-Fuß	×	×
14	RTTAV00006	Supporto regolatore	Support regulateur	Regulator support	Reglerhalterung	×	×
15	PABF800285	Fianco destro	Côté droit	Right side	Rechte Seite	×	×
16	RTBF900101	Cerniera fissa vasca	Charnière fixe cuve	Fixed basin hinge	Festes Wannenscharnier	×	×
17	RTBF900099	Perno cerniera anteriore	Tourillon charnière avant	Front hinge pin	Scharnierzapfen	×	×
18	RTBF900100	Cerniera mobile vasca	Charnière mobile cuve	Mobil basin hinge	Bewegliches Wannenscharnier	×	×
19	PABF800286	Fianco sinistro	Côté gauche	Left side	Linke Seite	×	×
20	RTBF800300	Vasca	Cuve	Tank	Wanne	×	×
21	GABF800106	Coperchio	Couvercle	Cover	Topfdeckel	×	×
22	RTCP800031	Maniglia coperchio	Poignée du couvercle	Handle for cover	Deckelgriff	×	×
23	RTBF800080	Gruppo cerniera coperchio	Charnière couvercle	Cover hinge	Abdeckungsscharnier	×	×
24	RTCP800030	Terminale destro maniglia	Terminal droite charnière	Right terminal hinge	Rechter Endverschluß	×	×
25	RTCP800029	Terminale sinistro maniglia	Terminal gauche charnière	Left terminal hinge	Linker Endverschluß	×	×
26	RTCP800028	Regolatore molla coperchio	Régulateur ressort couvercle	Cove spring adj. device	Federregler Abdeckung	×	×
27	RTBF800103	Molla cerniera coperchio	Réssort pour charnière	Sprieng for cover hinge	Scharnierfeder	×	×
28	RTCP800027	Guida molla cerniera	Guide pour réssort charnière	Spring for hinge spring	Türfederführung	×	×
29	GACU800014	Griglia caminetto	Grille de la cheminée	Chimney grate	Schornsteinrost	×	×
30	GABF800111	Caminetto superiore	Cheminée superieure	Superior chimney	Oberer Schornstein	×	×
31	PABF800280	Posteriore inox	Panneau derrière inox	Stainless steel back panel	Inox-Rückwand	×	×
32	PABF900243	Piano inferiore inox	Plan inferieur	Lower plan	Untere Ebene	×	×
33	GABF800107	Contorno raccogliolio	Contour	Oil collection edge	Ölsammelrand	×	×
34	GABF800112	Traversa posteriore	Croisillon posterieure	Rear crossbar	Hintere Querträger	×	×
35	PABF900227	Piantana postreiore destra	Colonna arrière droite	Rear right support	Säule hinten rechts	×	×
36	RTMIN00123	Seeger Ø 10	Seeger Ø 10	Seeger Ø 10	Seeger Ø 10	×	×

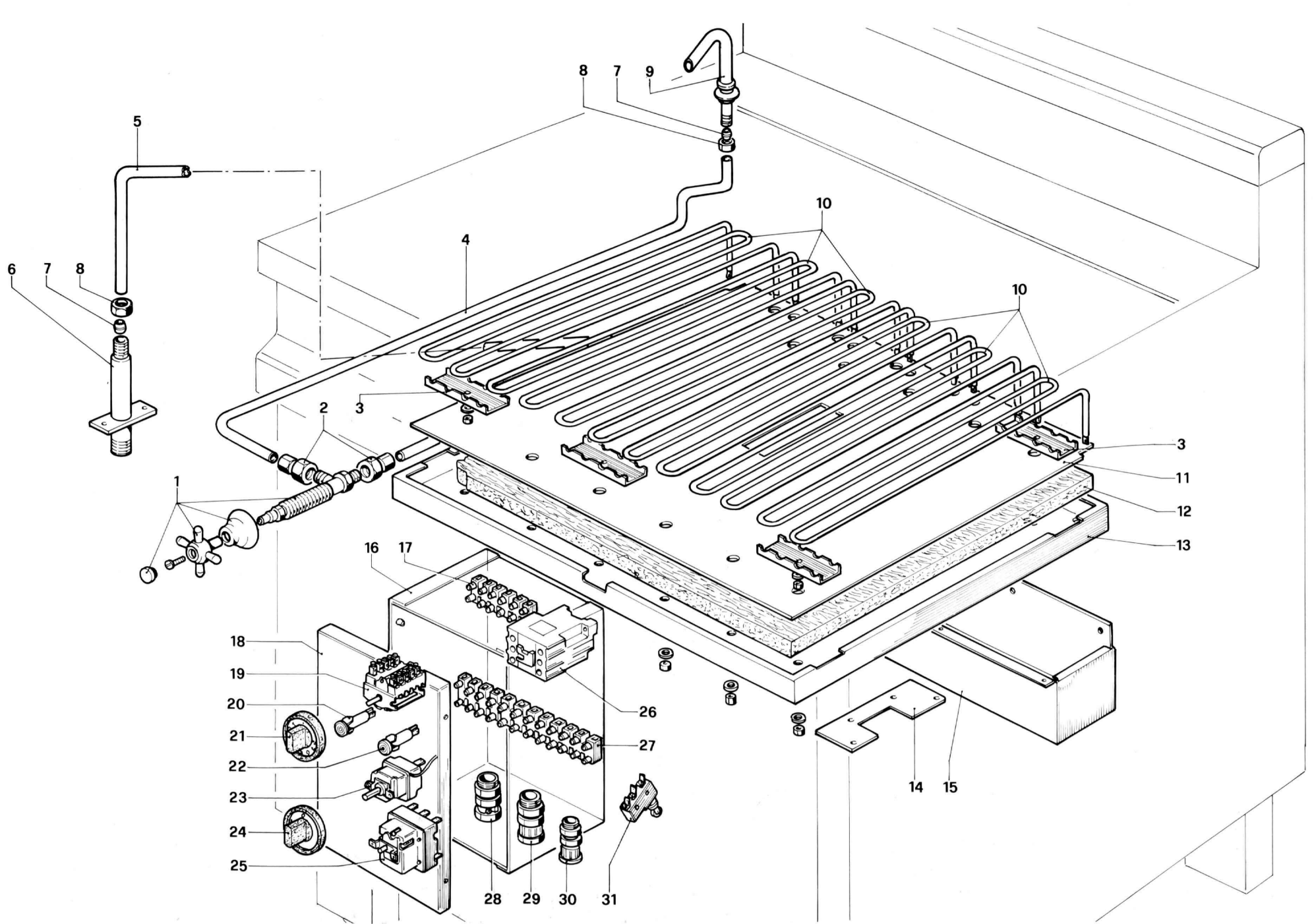

TAV. 59		IMPIANTO ELETTRICO	EQUIPEMENTS ÉLECTRIQUE	ELECTRIC SYSTEM EQUIPMENT	ELEKTRISCHE ANLAGE	EBR	EBRA
	Codice	Denominazione	Denominaton	Denominaton	Bezeichnung		
1	RTCP800018	Rubinetto acqua	Robinet de l'eau	Water tap	Wasserhahn	×	×
2	RTBF800126	Niples completo Ø 10	Niples pour tuyau Ø 10	Nipples for pipe Ø 10	Nippel für Schlauch Ø 10	×	×
3	PABF900131	Squadretta fissaggio resistenza	Eguerre fixation résistance el.	Bracket for el. resistor attachment	Winkeleisen	×	×
4	PABF900202	Tube alimentazione erogatore	Tuyau remplissage bac	Tank filling pipe	Wannenfüllrohr	×	×
5	PABF800292	Tube alimentazione rubinetto	Tuyau distribution eau	Water feeding pipe	Hahnversorgungsrohr	×	×
6	GABF800035	Attacco acqua	Attaque de l'eau	Water connection	Wasseranschluß	×	×
7	RTCU900012	Bicono Ø 10	Bicone pour tuyau Ø 10	Bicone for pipe Ø 10	Zweikegel Ø 10	×	×
8	RTCU900013	Calotta Ø 10	Ecrou pour tuyau Ø 10	Nut for pipe Ø 10	Mutter für Schlauch Ø 10	×	×
9	RTBF800041	Erogatore acqua	Distributeur eau	Water distributor	Wasserversorger	×	×
10	RTBF800026	Resistenza elettrica 1500W 240V.	Résistnce électrique 1500W 240V.	Over heating elect. 1500W 240V.	Elekt. Widerstände 1500W 240V.	×	×
11	PABF900246	Contenitore interno isolante	Boîtier isolant résistances el.	El. resistor insulating container	Isoliermittelbehälter El. Widerstände	×	×
12	MPIS000003	Pannello isolante	Panneau isolant	Insulating panel	Isolierplatte	×	×
13	PABF900244	Contenitore esterno isolant	Boîtier externe pour isolant	Exterior container for insulation	Externer Isoliermittelbehälter	×	×
14	PABF900248	Piastrina copriforo contenitore	Plaque bouche-trou	Hole cover plate	Lochabdeckung	×	×
15	PABF900245	Protezione morsett. resistenze	Protection bornier résistances	El. resistor terminal strip gnard	Schutzvorrichtung Klemmbretter	×	×
16	PABF900230	Scatola portacomandi	Boîtier porte-commandes	Control box	Steuerungskasten	×	×
17	PABF900045	Morsettiera 6 poli	Groupe de connection de cables	Terminal bloc 6 poles	Klemmenbreit 6 polig	×	×
18	GABF900117	Coperchio scatola	Couvercle boîtier	Box cover	Kastendeckel	×	×
19	RTCU700212	Commutatore	Commutateur	Commutator	Kommutator	×	×
20	RTCU900290	Lampada spia verde	Lampe témoin vert	Green warning light	Grüne Kontrolleuchtenbirne	×	×
21	RTCU800062	Manopola commutatore	Bouton du commutateur	Commutator knob	Kommutatorkugelgriff	×	×
22	RTCU900072	Lampada spia gialla	Lampe témoin jaune	Yellow warning light	Gelbe Kontrolleuchtenbirne	×	×
23	RTCU700085	Termostato	Thermostat	Thermostat	Thermostat	×	×
24	RTCU800103	Manopola termostato	Bouton du thermostat	Thermostat knob	Thermostat-kugelgriff	×	×
25	RTBF800192	Termostato Limit	Thermostat Limit	Limit thermostat	Limit Thermostat	×	×
26	RTBF800153	Relais EBR	Relais EBR	Relais	Relais	×	×
27	RTBF800149	Morsettiera 12 poli	Groupe de connection de cables	Terminal bloc 12 pole	Klemmenbreit 12 polig	×	×
28	RTBF800138	Fissacavo Ø 9	Fixe-cable Ø 9	Cable clamb Ø 9	Kabelhalter Ø 9	×	×
29	RTCU700102	Passacavo Ø 9	Passe-cable Ø 9	Cable guide Ø 9	Kabelrinne Ø 9	×	×
30	RTCU700103	Passacavo	Passe-cable	Cable guide	Kabelrinne	×	×
31	RTBF800113	Microinterruttore sollevam. vasca	Micro-interrupteur	Microswitch	Mikroschalter	×	×