

# EH330 and EH430 Service Parts

This part list contains the service parts for the Eclipse 1200, 1400, 1800 and 2000 systems.

The models that are covered include:

- EH330
- EH430
- C1200CP
- C1410CP
- C1800CP
- C2000CP
- ERC1086
- ERC2086

## Table of Contents

EH330 Cabinet . . . . .	Page 2
EH430 Cabinet . . . . .	Page 3
EH330 and EH430 Interior Parts . . . . .	Page 4
EH330 and EH430 Refrigeration System . . . . .	Page 5
EH330 Evaporator Compartment . . . . .	Page 6
EH430 Evaporator Compartment . . . . .	Page 7
EH330 or EH430 Electrical . . . . .	Page 8
CP Cabinet . . . . .	Page 9
C1200CP Refrigeration System . . . . .	Page 10
C1410CP Refrigeration Systems . . . . .	Page 11
C1800CP Refrigeration System . . . . .	Page 12
C2000CP Refrigeration System . . . . .	Page 13
CP Control Box . . . . .	Page 14
Remote Condensers . . . . .	Page 15
EH330 or EH430 Schematic Diagram . . . . .	Page 16
EH330 or EH430 Wiring Diagram . . . . .	Page 17
CP Single Phase Schematic Diagram . . . . .	Page 18
CP Single Phase Wiring Diagram . . . . .	Page 19
CP Three Phase Wiring Diagram . . . . .	Page 20
CP Three Phase Schematic Diagram . . . . .	Page 21

# EH330 and EH430 Service Parts

## CP Cabinet

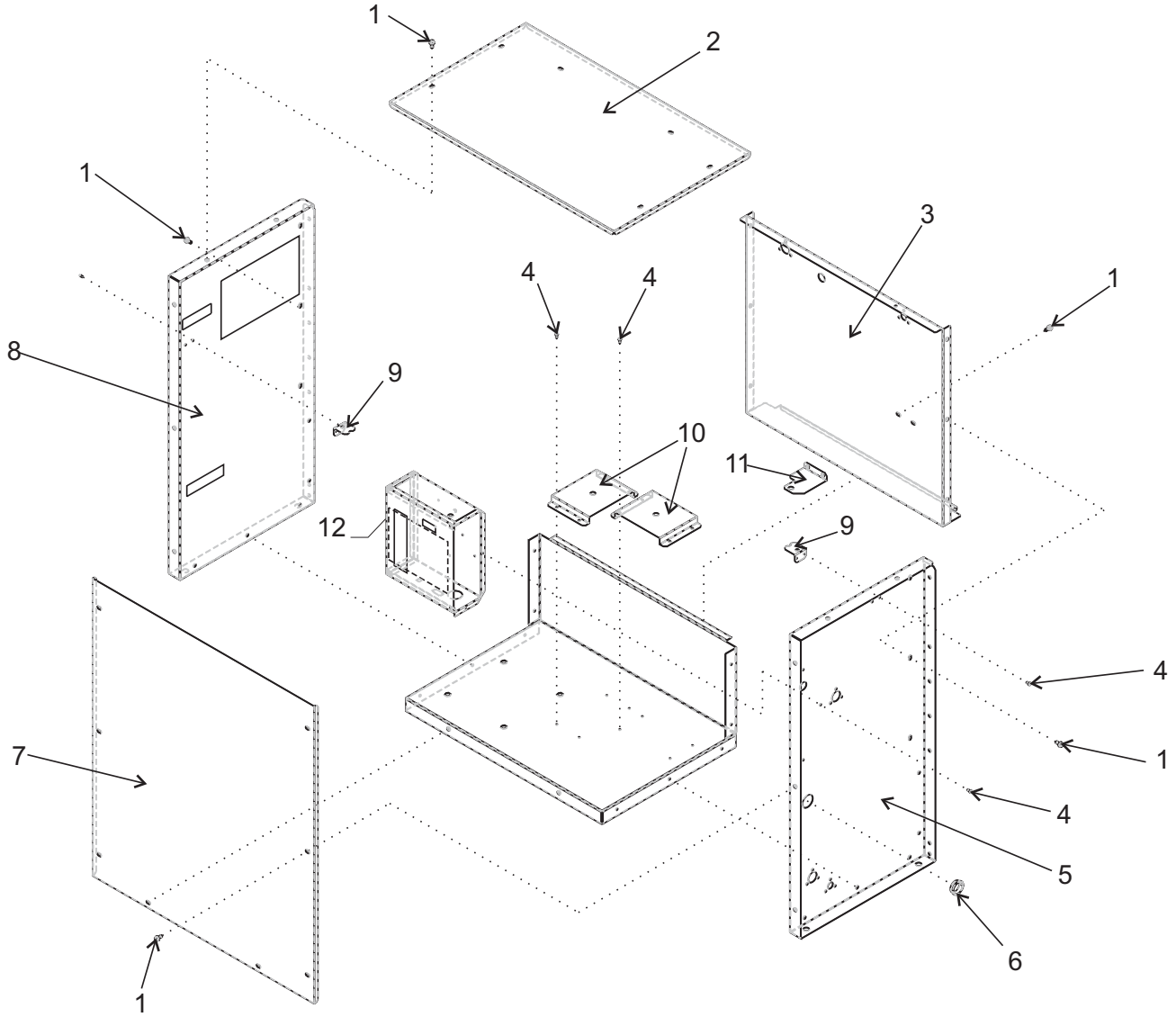

Item Number	Part Number	Description	Item Number	Part Number	Description
1	03-1645-01	Screw	10	A37948-001	Rec btm bracket - all or accumulator bracket - C1200CP or C1410CP
2	A37853-001	Top cover		A39319-001	Accumulator bracket, C1800CP or C2000CP
3	A37845-001	Back panel	11	A37949-001	Receiver top bracket
4	03-1531-01	Screw	12	A38430-001	Control box cover
5	A37829-001	Right side panel			
6	12-1213-20	Snap bushing			
7	A37896-001	Front cover			
8	A37829-002	Left side panel			
9	A37962-001	Service valve bracket			

# EH330 and EH430 Service Parts

## C2000CP Refrigeration System

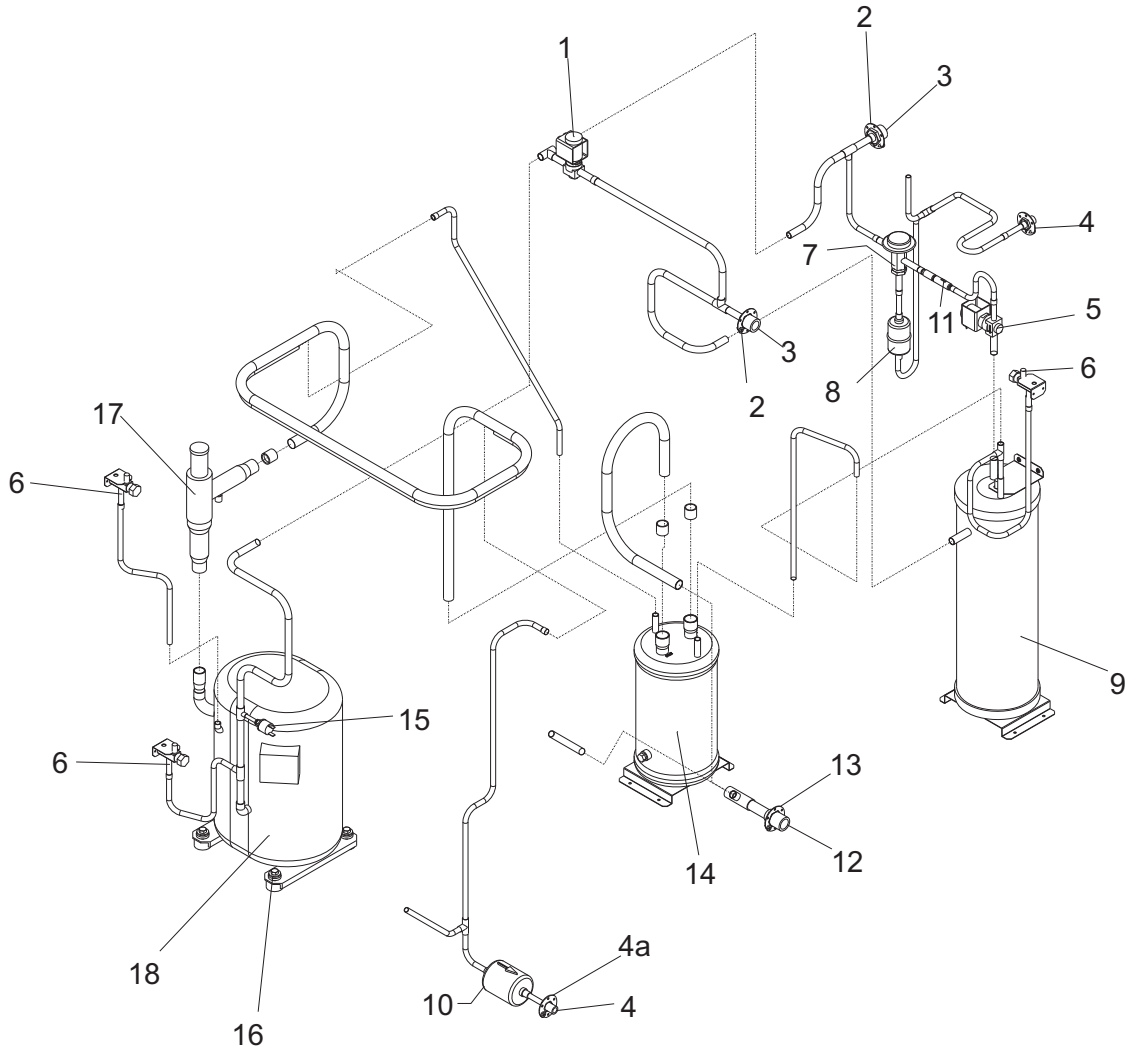

Item Number	Part Number	Description
1	11-0507-03	By pass valve
2	16-0701-14	Mounting flange
3	16-0850-01	Discharge quick connect
4	16-0850-03	Liquid quick connect
4a	16-0701-07	Mounting flange
5	11-0546-01	Liquid inlet valve
6	16-0832-20	Access valve
7	16-1044-01	Headmaster
8	02-3231-02	Filter
9	16-1085-01	Receiver
10	02-3319-02	Filter drier
11	16-1029-01	Check valve
12	16-0850-04	Suction quick connect
13	16-0701-18	Mounting flange
14	16-1122-21	Accumulator
15	11-0501-22	Hi pressure cut out
16	18-2300-27	Mounting grommet
	18-2300-26	Sleeve
	03-1406-07	Washer
	03-1404-15	Cap screw
17	16-1096-02	CPR valve
18	Compressors	
	C2000CP-32	single phase 18-8923-22
	C2000CP-2	three phase 18-8923-23

All compressors are 208-230 volt, 60 Hz.  
 Single phase compressors include starting components. All include a drier and crankcase heaters.

# EH330 and EH430 Service Parts

## CP Control Box

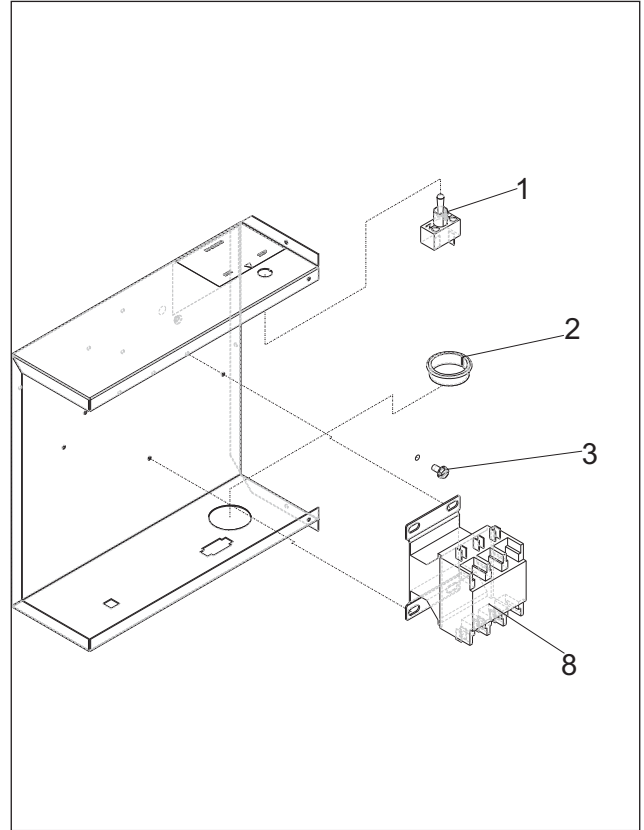
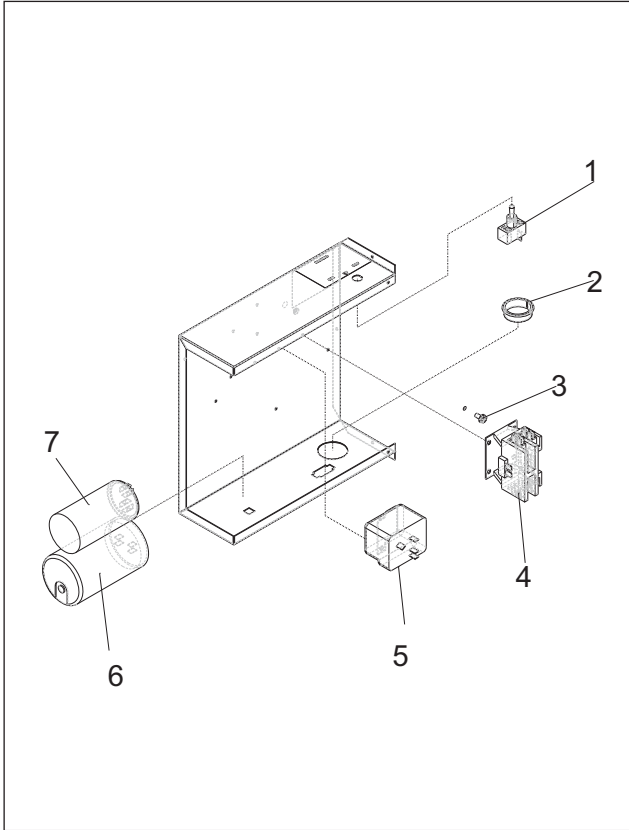

Item Number	Part Number	Description
1	12-0426-01	Toggle switch
2	12-1213-20	Snap bushing
3	03-1531-01	Mounting screw
4	12-2469-01	Single phase contactor

		C1200CP-32	C1410CP-32	C1800CP-32	C2000CP-32
5	Potential Relay	18-1903-46	18-1903-46	18-1903-62	18-1903-62
6	Start Capacitor	18-1901-48	18-1901-48	18-1901-27	18-1901-27
7	Run Capacitor	18-1902-55	18-1902-55	18-1902-27	18-1902-27

8	12-2533-01	Three phase Contactor
Not Shown:		
9	12-2836-02	Transformer, 230 to 24

# EH330 and EH430 Service Parts

## Remote Condensers

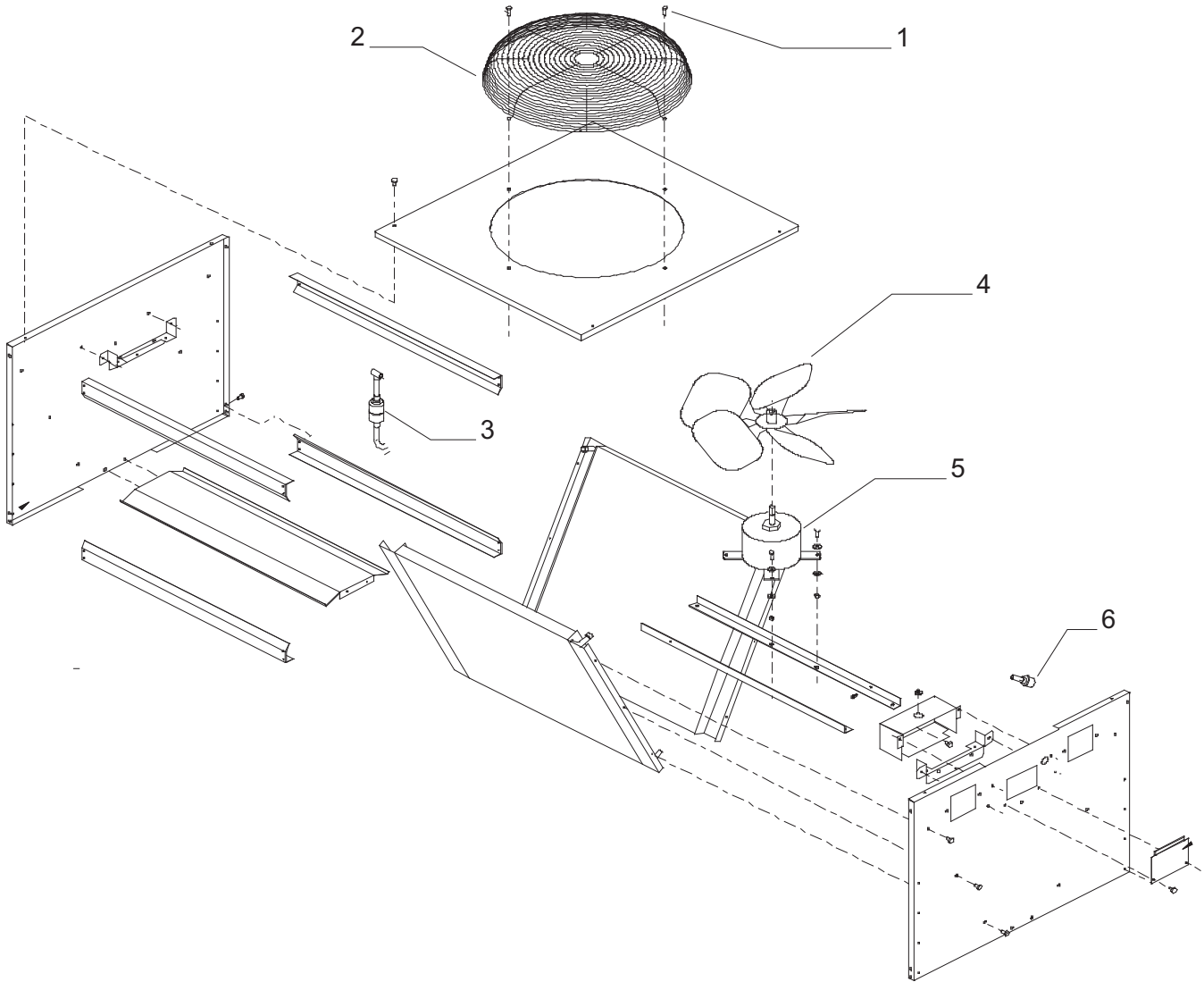

### Model ERC1086

Item Number	Part Number	Description
1	03-1405-08	Screw
2	02-3575-01	Fan guard
3	02-3231-03	Filter
4	18-8816-01	Fan blade
5	12-2651-01	Fan motor
6	16-1057-04	Quick connect, disch
	16-1057-03	Quick connect, liquid

Not Shown:

A37169-001	Leg
A37170-001	Leg brace
03-1645-01	Screw for legs

### ERC2086

Item Number	Part Number	Description
1	03-1405-08	Screw
2	02-3770-01	Fan guard
3	02-3231-03	Filter
4	18-8820-01	Fan blade
5	12-2717-01	Fan motor
6	16-1057-04	Quick connect, disch
	16-1057-03	Quick connect, liquid

Not Shown:

A37169-001	Leg
A37296-001	Leg brace
03-1645-01	Screw for legs

# EH330 and EH430 Wiring Diagrams

## CP Single Phase Schematic Diagram

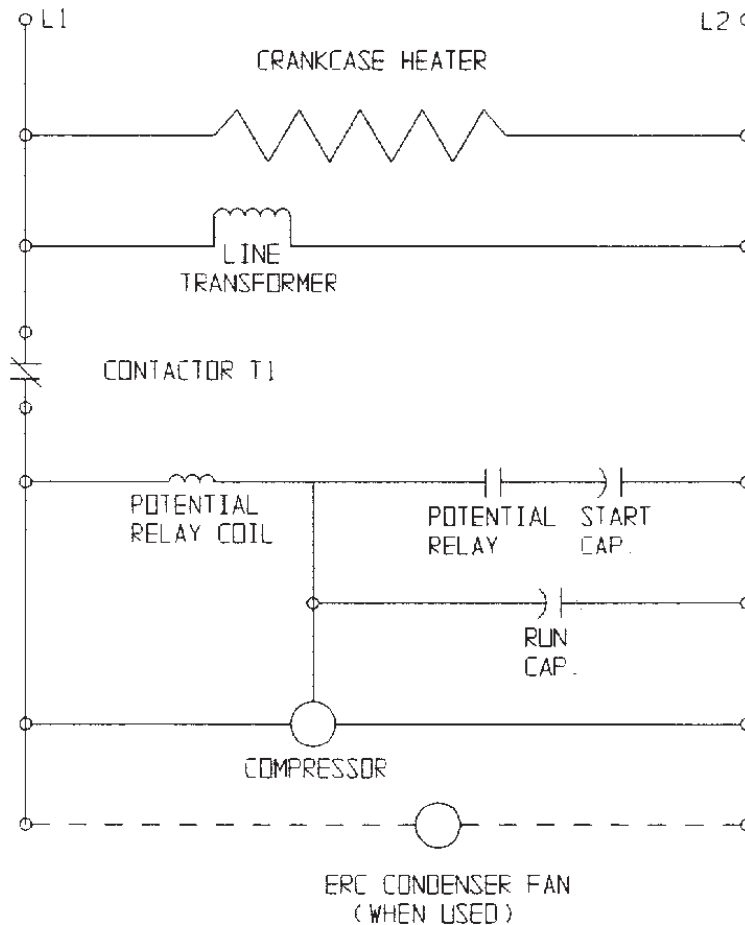
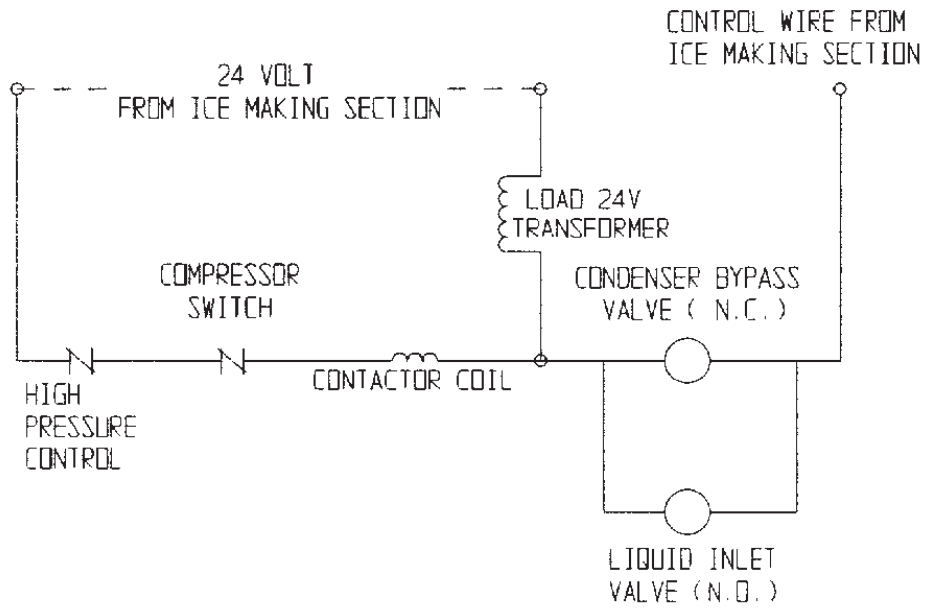

# EH330 and EH430 Wiring Diagrams

## CP Single Phase Wiring Diagram

17-3130-01

USE COPPER CONDUCTORS ONLY

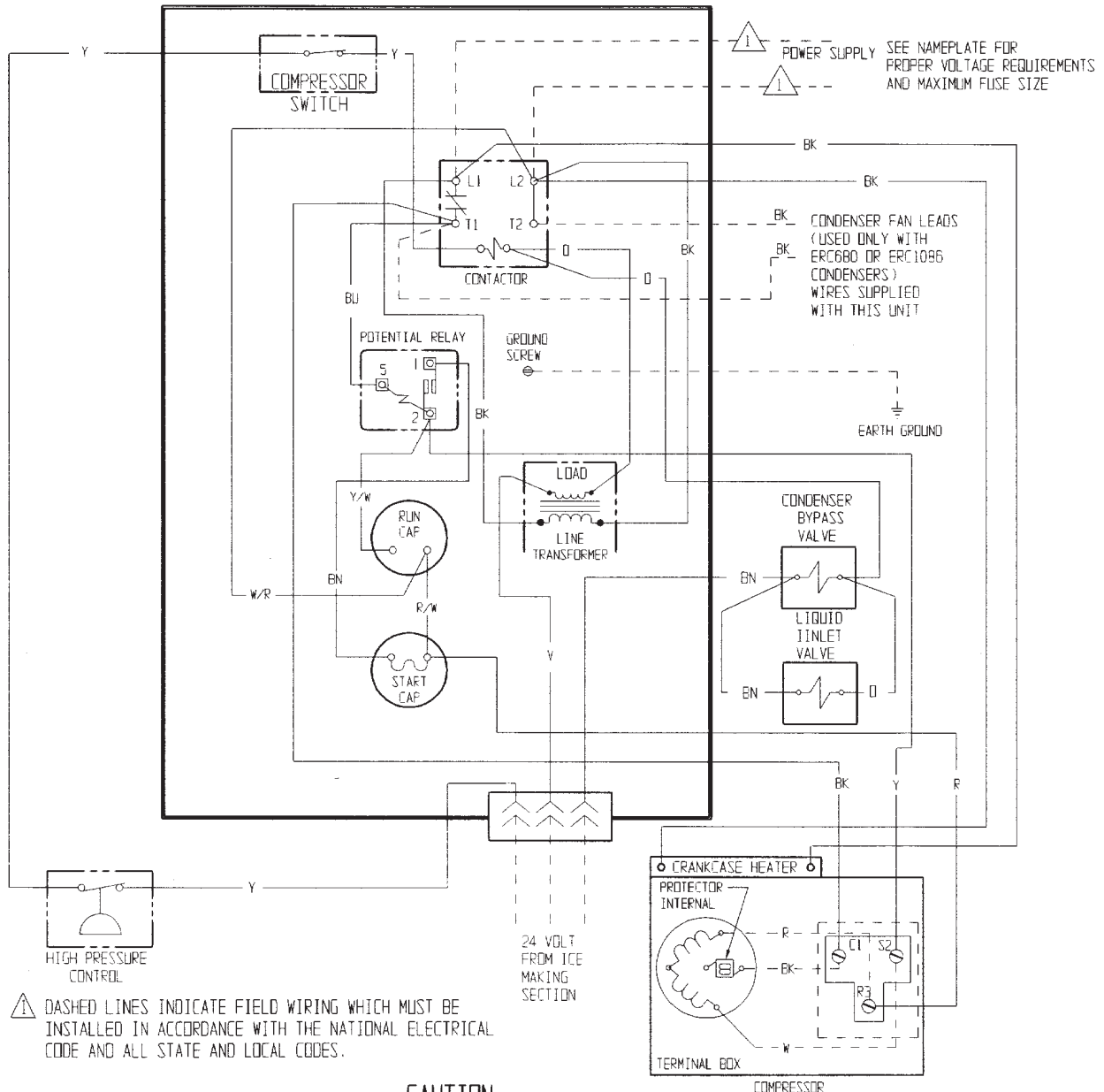

**CAUTION:**

MORE THAN ONE DISCONNECT MEANS MAY BE REQUIRED TO DISCONNECT ALL POWER TO THIS UNIT.

THIS UNIT MUST BE GROUNDING.

# EH330 and EH430 Wiring Diagrams

## CP Three Phase Wiring Diagram

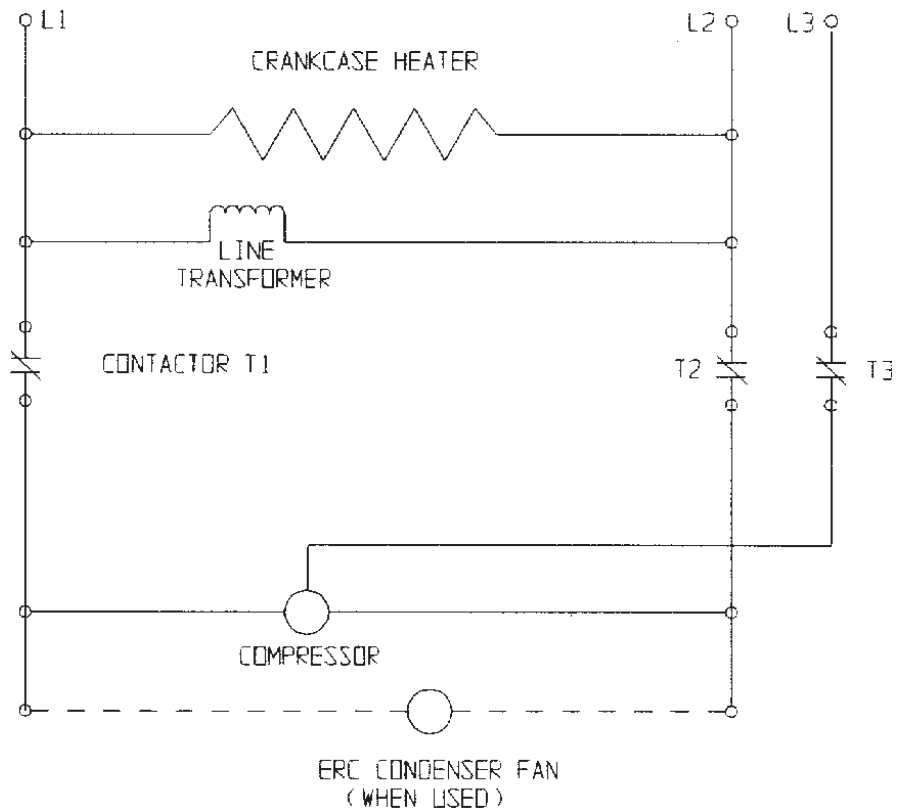
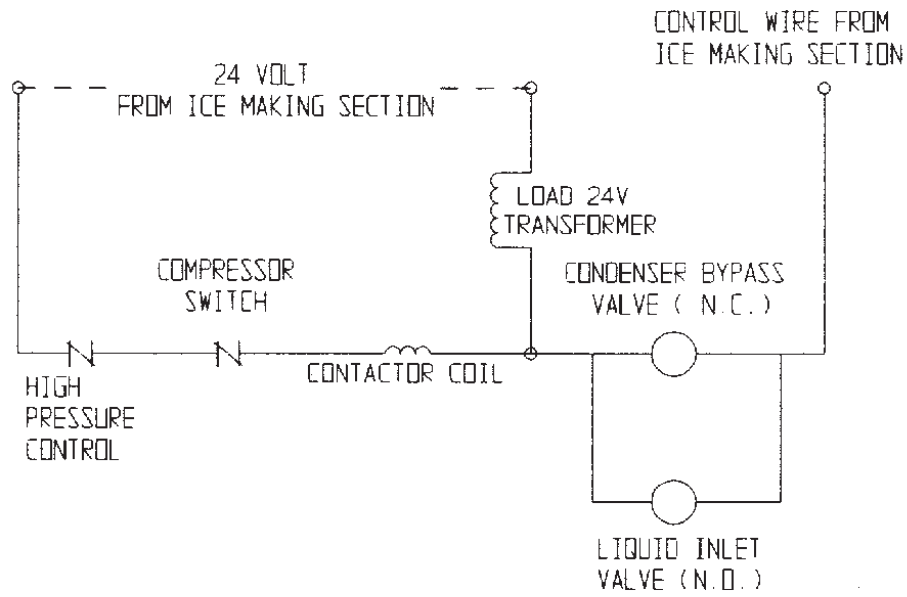



# EH330 and EH430 Wiring Diagrams

## CP Three Phase Schematic Diagram

17-3131-01

USE COPPER CONDUCTORS ONLY

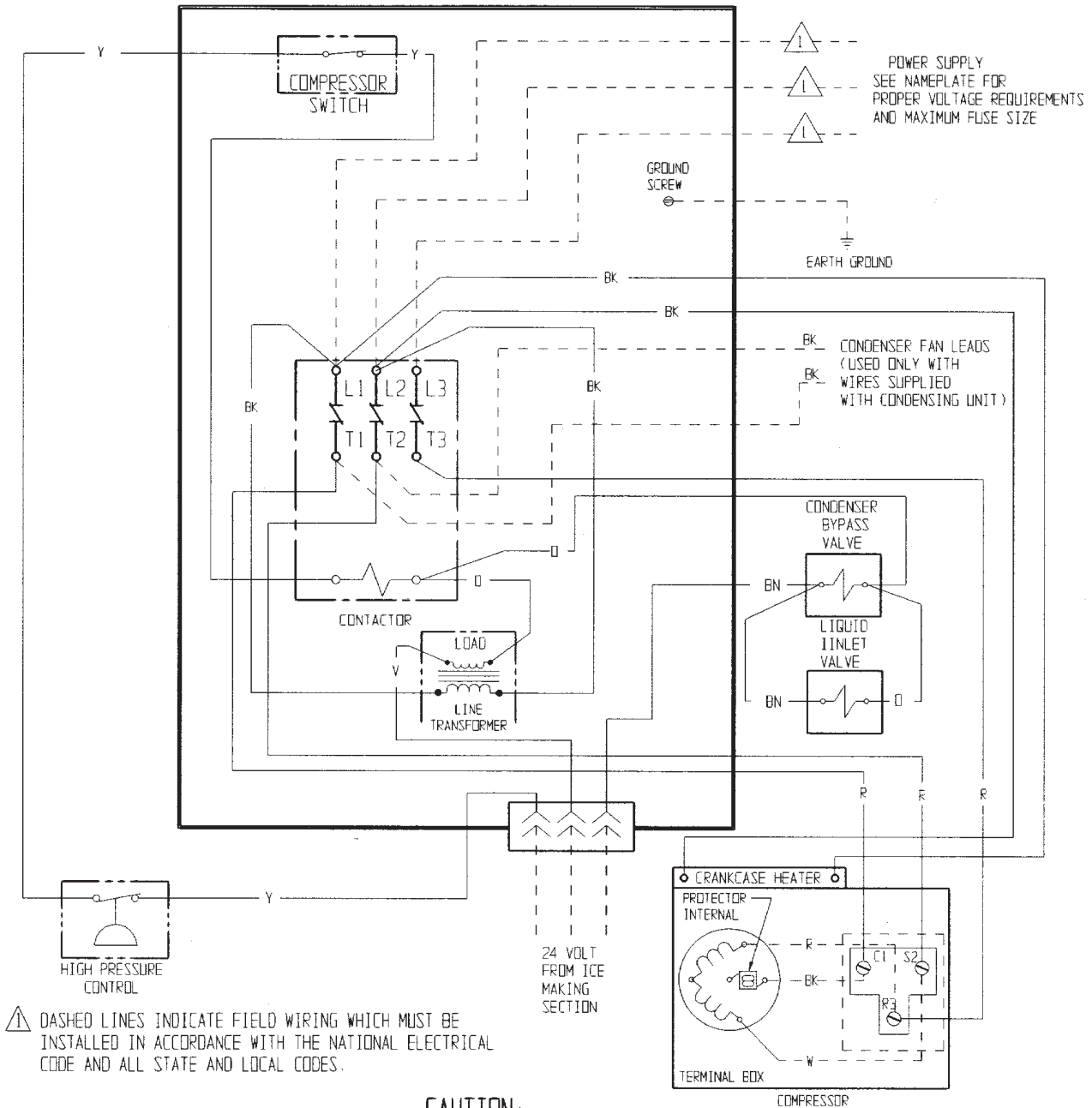

⚠ DASHED LINES INDICATE FIELD WIRING WHICH MUST BE INSTALLED IN ACCORDANCE WITH THE NATIONAL ELECTRICAL CODE AND ALL STATE AND LOCAL CODES.

### CAUTION:

MORE THAN ONE DISCONNECT MEANS MAY BE REQUIRED TO DISCONNECT ALL POWER TO THIS UNIT.

THIS UNIT MUST BE GROUNDED.