

CME1856W Service Parts

This parts list contains the part numbers and description of the replacement parts available for this model. To avoid costly and time consuming errors, double check the model and voltage before ordering a part.

TABLE OF CONTENTS

Cabinet	PAGE 2
Water System	PAGE 3
Refrigeration	PAGE 4
Electrical	PAGE 5
BH900 Ice Storage Bin	PAGE 6
BH1650 Ice Storage Bin	PAGE 7
Kit Parts	PAGE 8
Single Phase Wiring Diagram	PAGE 9
Single Phase Schematic Diagram	PAGE 10
Three Phase Wiring Diagram	PAGE 11
Three Phase Schematic	PAGE 12

CME1856W Service Parts

Cabinet

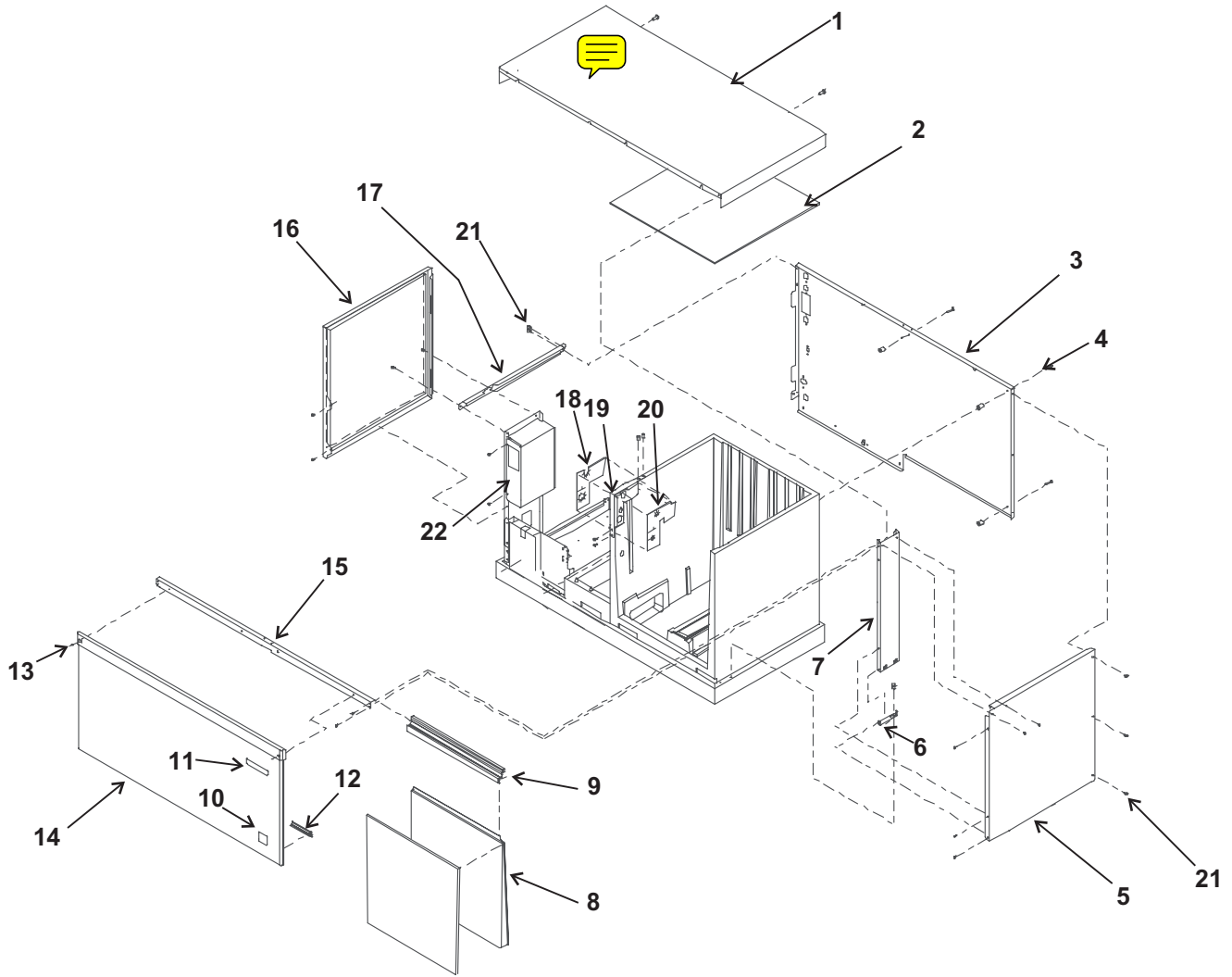

Item Number	Part Number	Description	Item Number	Part Number	Description
1	02-3823-21	Top panel, plastic	14	A37489-001	Front panel, SS, includes items 13 and 11
2	02-3686-01	Insulation	15	A37195-001	Channel, front top
3	A37671-001	Back panel	16	A37198-002	Left side panel, SS
4	03-1404-37	Screw	17	A37365-001	Left side channel
5	A37668-001	Right side panel, SS	18	02-3696-03	Left grommet
6	A37194-001	Right bottom channel	19	A37216-001	Bracket
7	A37213-001	Right side support	20	02-3696-02	Right grommet
8	02-3702-21	Evaporator cover & ins	21	03-1531-01	Screw
9	02-3701-01	Cover retainer	22	A37340-001	Control box cover
10	15-0792-02	CM ³ emblem			
11	15-0808-03	Emblem			
12	02-3699-01	Panel support clip			
13	03-1735-01	Front panel screw			

CME1856W Service Parts

Water System

Item Number	Part Number	Description
-------------	-------------	-------------

1	02-3613-01	Elbow
2	02-3725-01	Hose clamp
3	13-0617-48	O-ring
4	02-3518-01	Manifold
5	02-3519-01	Manifold right
6	13-0840-01	Plug
7	02-2527-01	Water distributor
8	A37315-021	Evaporator
9	02-3337-02	Ice deflector
10	02-3672-01	Right trough
11	02-3672-02	Left trough
12	A37337-001	Evap support
13	11-0540-21	Ice sensor (set)
14	02-3689-01	Ice sensor holder
15	02-3706-01	Upper inner splash panel

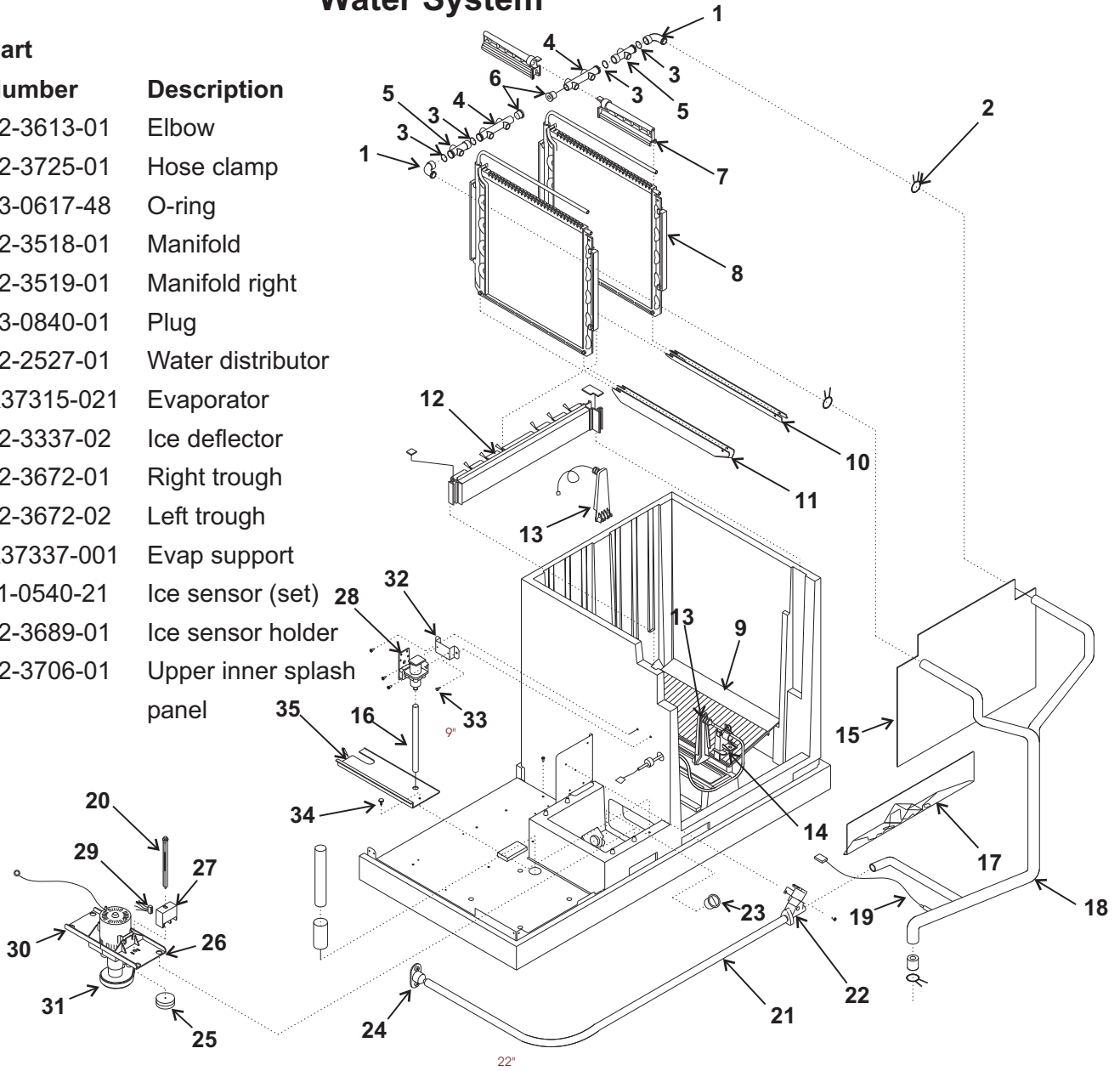

16	13-0674-02	Tube, order 1 unit	27	11-0539-51	Water level sensor
17	02-3680-01	Lower inner splash panel	28	12-2666-01	Water solenoid valve
18	02-3660-01	Water discharge hose		16-0355-00	Coupling half
19	11-0515-21	Temp sensor set	29	12-2665-01	Harness for water sensor
20	02-3383-06	Float stem	30	02-3388-05	Pump bracket
21	13-0674-06	Drain hose, order 2 units	31	12-2582-21	Water pump
22	11-0514-01	Purge valve	32	A37204-001	Bracket
23	02-3703-01	Drain plug	33	03-1404-18	Screw
24	02-3692-21	Drain fitting	34	03-1691-01	Nylon screw
25	02-3341-01	Float	35	02-3534-01	Reservoir cover
26	02-3388-04	Pump bracket			

CME1856W Service Parts

Refrigeration

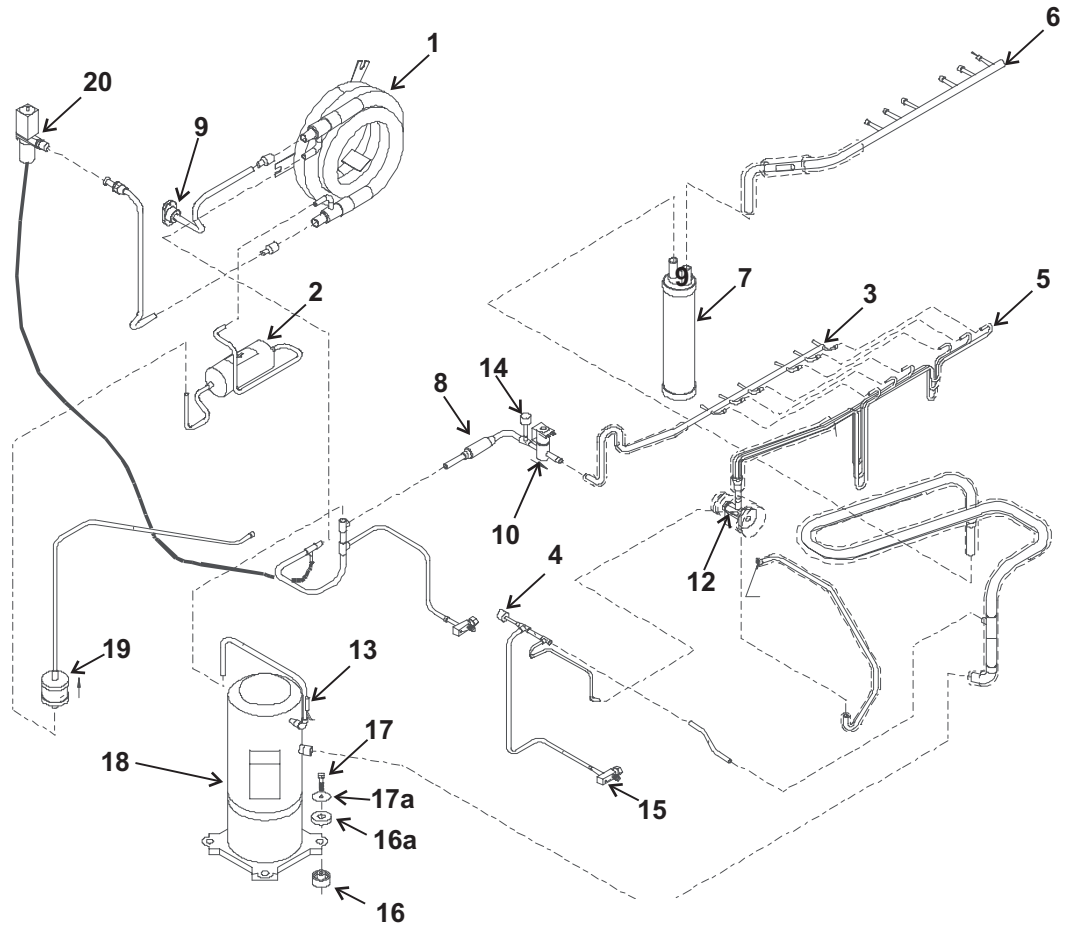
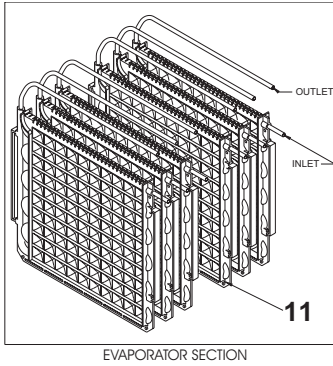

Item Number	Part Number	Description	Item Number	Part Number	Description
1	18-8865-21	Water cooled condenser	13	11-0515-21	Temp sensor set
2	02-2628-02	Receiver	14	11-0501-23	Hi pressure cut out
3	16-1050-01	Hot gas header	15	16-0832-20	Suction access valve
4	11-0502-21	Low pressure cut out		16-0832-03	Port cap
5	A37405-001	Distributor and tubes		16-0832-02	Stem cap
6	16-1055-01	Suction manifold	16	03-1729-01	Solid Mount
7	16-1031-21	Accumulator		03-3843-01	Rubber grommet
7a	A37209-001	Accumulator bracket	16a	03-1729-03	Rubber pad for sold mount
8	16-1063-03	Strainer for HGV	17	03-1405-20	Bolt
9	A31828-003	Drain fitting	17a	03-1729-02	Washer for solid mount
10	11-0507-22	Hot gas valve w/coil		03-1407-07	Washer for rubber grommet
	12-2719-23	Hot gas valve coil only		18-2300-26	Sleeve for rubber grommet
11	A37315-021	Evaporator	18	18-8821-02	Compressor, 60 Hz, single phase
12	16-1041-21	TXV, AAE 2 5Z		18-8821-03	Compressor, 60 Hz, 3 phase
	02-3792-01	Insulation for TXV		18-8828-01	crankcase heater for 3 phase
					Replacement compressors include a dryer
			19	02-3319-02	Dryer
			20	11-0478-02	Water reg valve

CME1856W Service Parts

Electrical

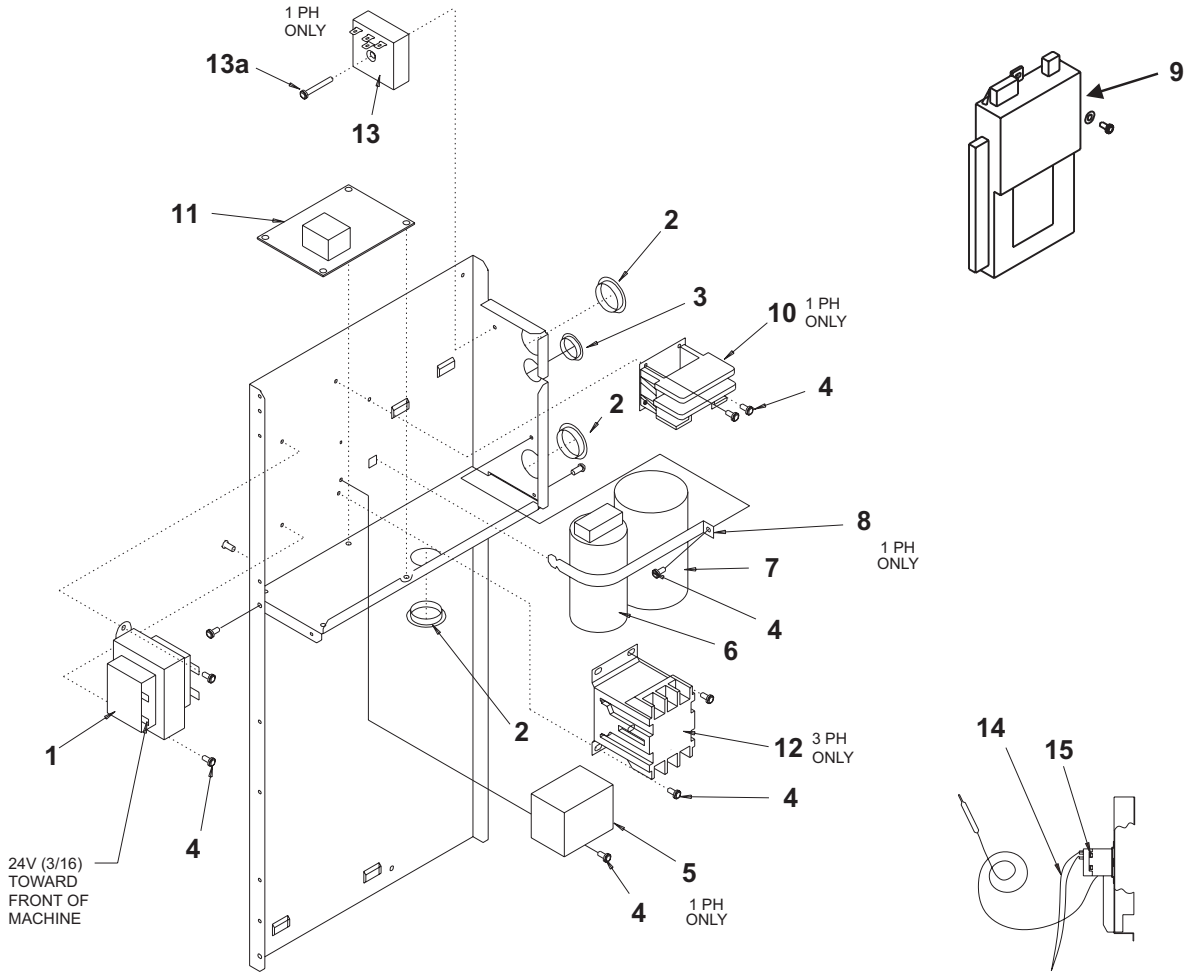

Item Number	Part Number	Description
1	A37217-001	Transformer
2	12-1213-11	Snap bushing
3	12-1213-10	Snap bushing
4	03-1531-01	Screw
5	18-1903-55	60 Hz potential relay
6	18-1902-59	Run capacitor
7	18-1901-58	60 Hz start capacitor
8	A37366-001	Strap
9	12-2838-23	Controller
10	12-2595-01	Single phase contactor
11	11-0531-22	Purge valve timer
	03-1727-01	Stand off
12	12-2533-01	3 phase contactor
13	11-0530-01	Time delay relay
13a	03-1531-10	Screw

Item Number	Part Number	Description
14	12-2701-01	Bin thermo harness
15	11-0521-21	Bin thermostat
Not Shown:		
	02-3740-01	Thermostat bracket
	03-1675-03	3 pronged knob
	12-2708-01	Lo voltage harness
	12-2732-01	Hi voltage harness

CME1856W Service Parts

BH900 Ice Storage Bin

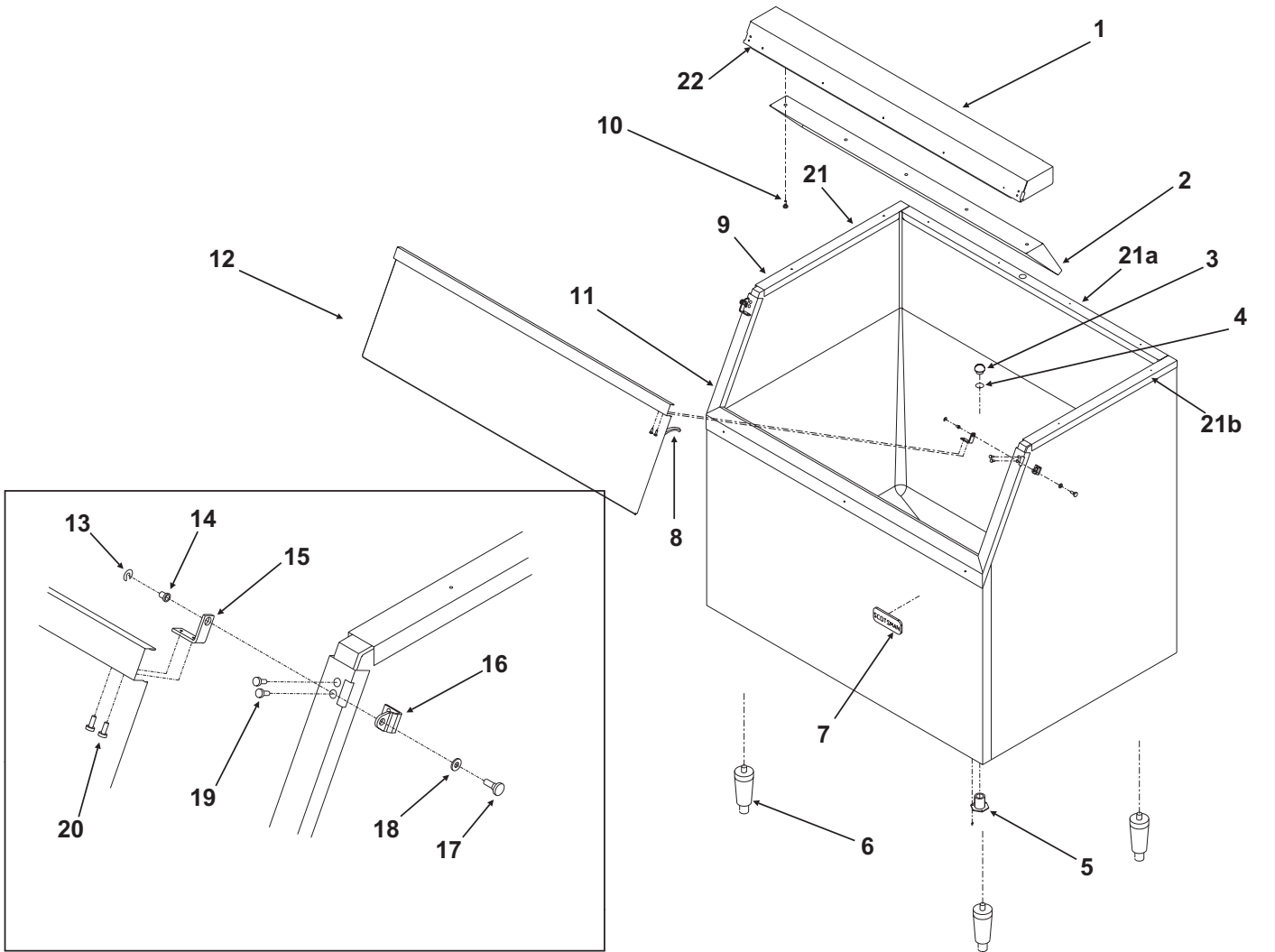

ITEM NUMBER	PARTS NUMBER	DESCRIPTION
1	A35322-001	Canopy Assembly
2	A35152-001	Ice Baffle
3	02-2809-01	Drain Top
4	13-0617-11	O-ring
5	02-3201-01	Drain casting
6	KLP2E Leg Kit, Black KLP2S Leg Kit, Nickel Plated	
7	15-0711-01	Emblem
8	13-0595-00	Door gasket (6.25' reg.)
9	19-0503-04	Bin gasket / ft
10	03-0727-11	Baffle screw
11	A35275-001 A37641-021	Door frame assy. Door frame, BH900S-C

ITEM NUMBER	PARTS NUMBER	DESCRIPTION
12	A35323-001	Door w/gasket - BH900
13	03-1539-09	"E" ring
14	02-2380-01	Hinge bushing
15	02-3195-01	Door hinge
16	02-3196-01	Bin hinge
17	02-2806-01	Shoulder screw
18	02-2380-02	Spacer
19	03-1403-29	Screw 10-24
20	03-1403-24	Screw 10-24
21	A35280-001	Left bin channel
21a	A35311-001	Back bin channel
21b	A35279-001	Right bin channel
22	02-3202-01	Trim guard

CME1856W Service Parts

BH1650 Ice Storage Bin

“Z” Brackets are used when attaching CME1356 or CME1656 to bin. Attaching screw pn: 03-1645-01

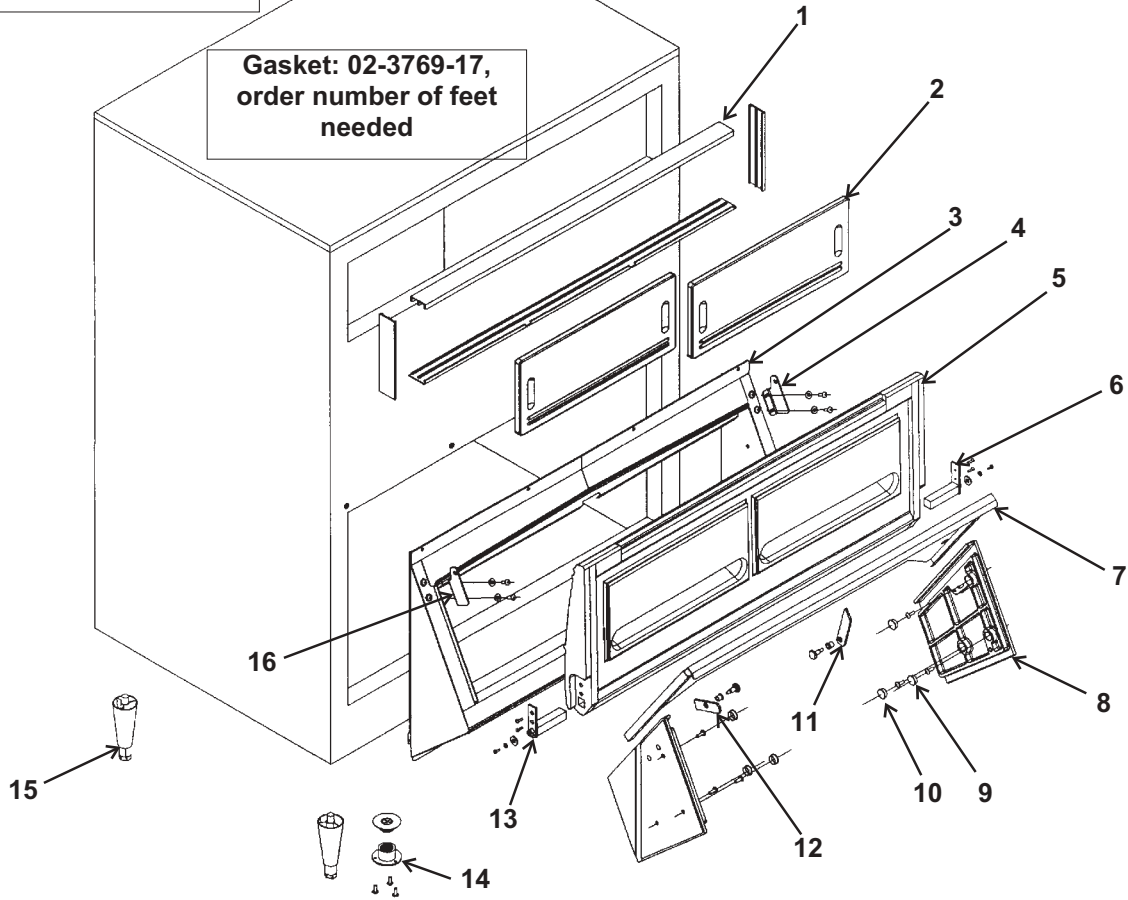

Item Number	Part Number	Description	Item Number	Part Number	Description
1	02-3769-02	Track	12	02-3769-15	Ice gate retainer
2	02-3769-16	Window	13	02-3769-06	Left hinge
3	02-3769-04	Lower frame assembly	14	02-3769-01	Plastic drain
4	02-3769-08	Left and right hinges	15	KLP2S	Legs
5	02-3769-05	Door with door hinges	Not Illustrated:		
6	02-3769-07	Right hinge		02-3769-18	Probe tool
7	02-3769-09	Ice gate		02-3769-19	Plastic Ice shovel.
8	02-3769-12	End plate guide (pair)		02-3775-01	Z brackets
9	02-3769-13	Screws for end plat			
10	02-3769-14	Plugs for end plate			
11	02-3769-10	Catch for ice gate			

CME1856W Service Parts

Kit Parts

Stacking Kit,KSCME6-LG-B

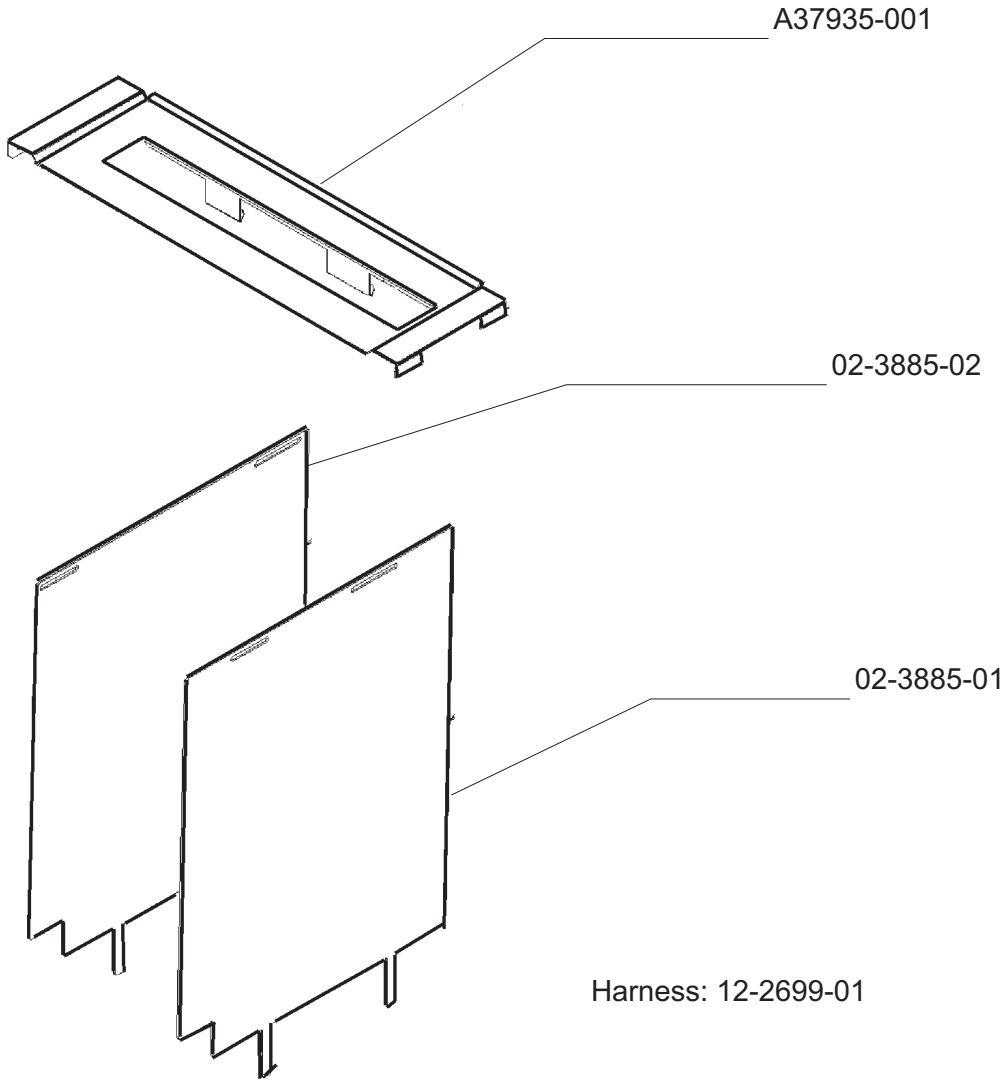

CME1856W Service Parts

Three Phase Wiring Diagram

17-2892-01

USE COPPER CONDUCTORS ONLY

⚠ DASHED LINES INDICATE FIELD WIRING WHICH MUST BE INSTALLED IN ACCORDANCE WITH THE NATIONAL ELECTRICAL CODE AND ALL STATE AND LOCAL CODES.

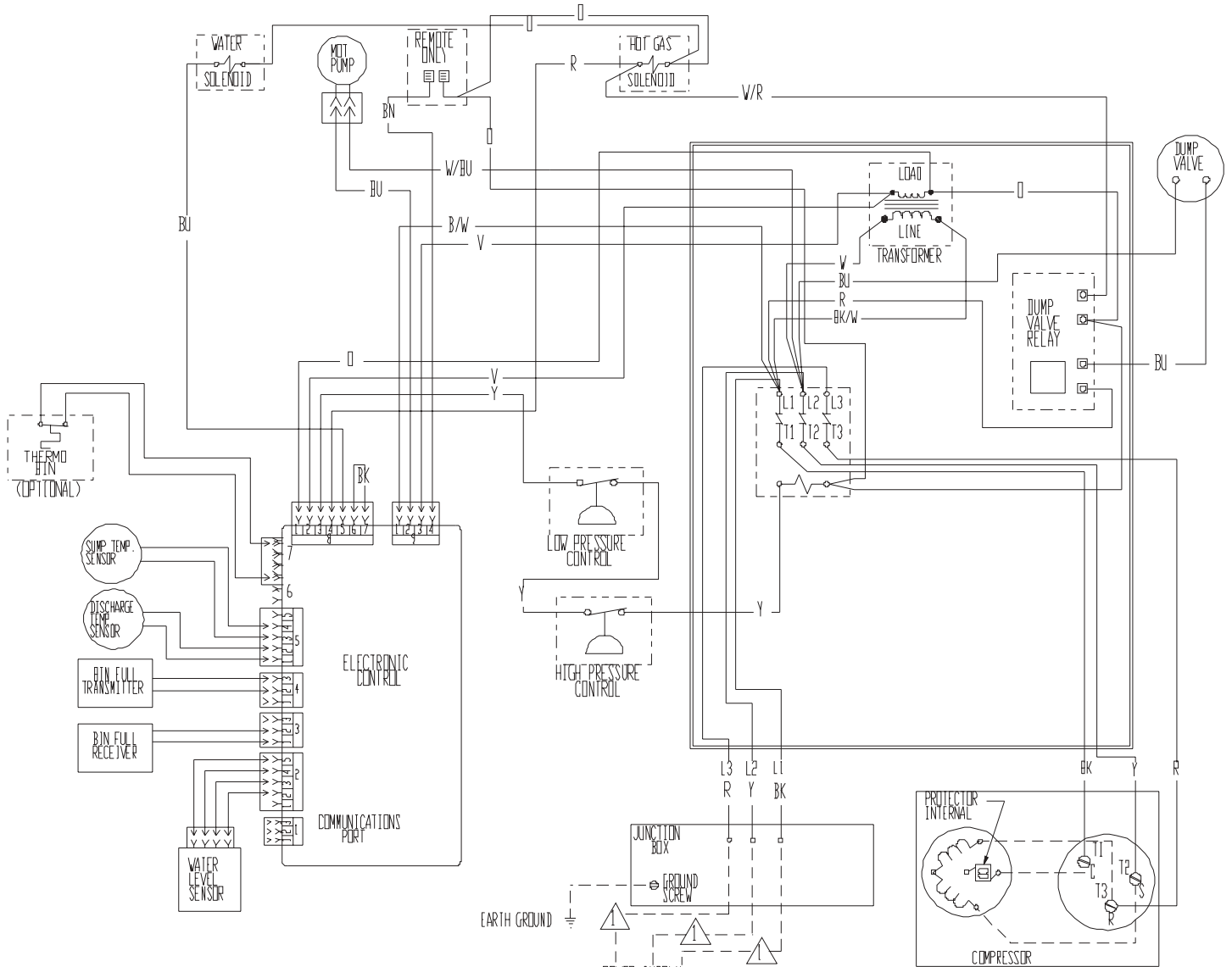

THIS UNIT MUST BE GROUNDED.

CAUTION:
MORE THAN ONE DISCONNECT MEANS MAY BE REQUIRED TO DISCONNECT ALL POWER TO THIS UNIT.

SEE NAMEPLATE FOR PROPER VOLTAGE REQUIREMENTS AND MAXIMUM FUSE SIZE

CME1856W Service Parts

Three Phase Schematic

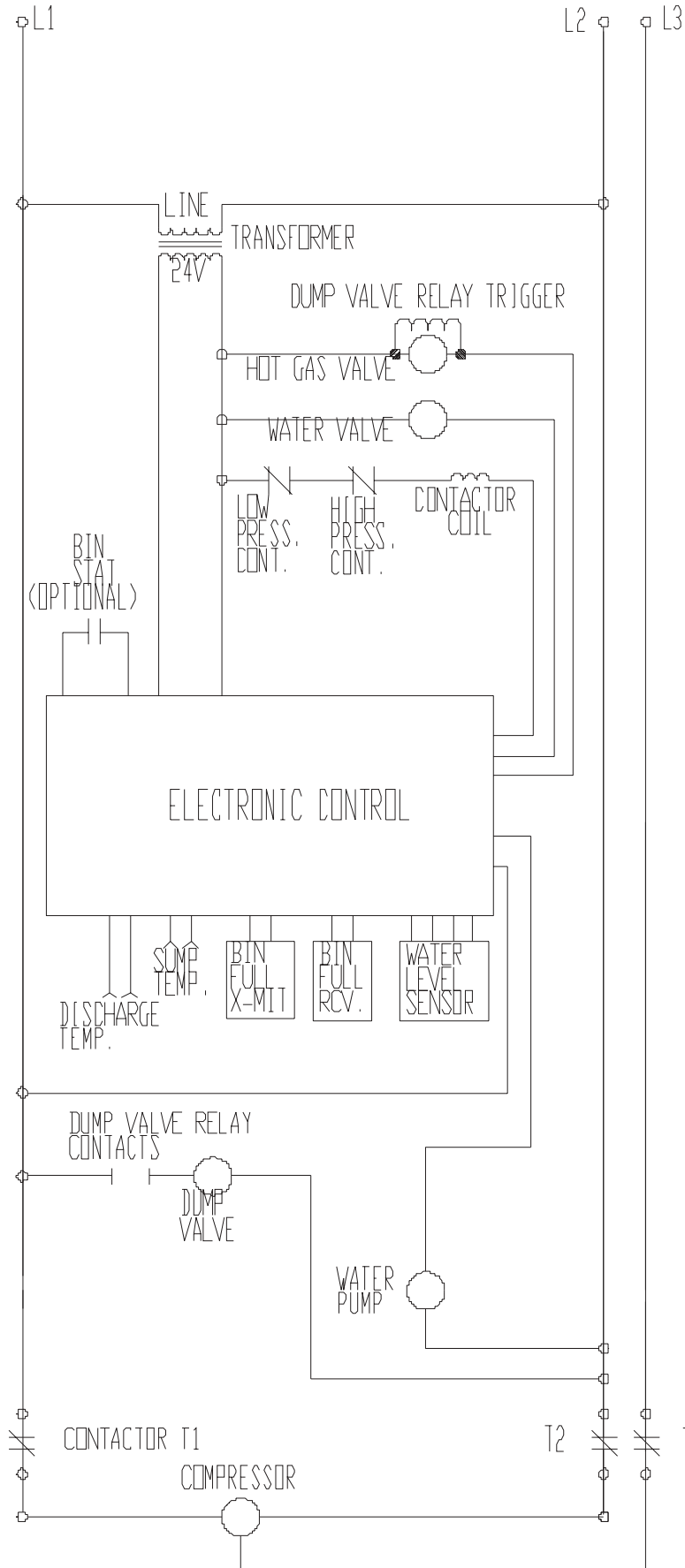

SERVICE BULLETIN

Subject: Controller Cover

Affects all versions of models: CME1356, CME1656, CME1856 and CME2006

The above models are now manufactured with a sheet metal cover over the top of the controller.

Service controllers also are now shipped with a cover that should be applied to these models whenever replacing the controller if the machine does not already have a cover installed.

Whenever cleaning or servicing any unit, check to see whether it has a cover over the controller like the one shown below. If it does not, Scotsman recommends installing a cover. A separate part is now available for this purpose. Its part number is **A37480-021**. It mounts over the top end of the controller and is secured by two sheet metal screws. Use the cover as a template and drill two 1/8" holes for the two screws.



Controller Cover



Cover Installed on Unit

Scotsman is shipping a supply of covers to all Scotsman Distributors and listed service agencies. A supply of covers should be carried by each service person on service calls so a cover may be installed on the unit being cleaned or serviced if one is not already in place. Additional covers may be obtained free of charge from Scotsman, through the local Scotsman Distributor, as needed.