

TAV.74		Friggitrice elett. EF90	Friteuse électrique	Electric fryer	Elektrische Friteuse	EF90
	Codice	Denominazione	Denominaton	Denominaton	Bezeichnung	
1	RTBF800233	Attacco magnetico	Attaque magnetique	Magnetic connection	Magnetanschluß	×
2	RTBF800225	Filtro vasca olio	Filtre pour la cuve huile	Oil tank filter	Ölbeckenfilter	×
3	PACU800159	Porta sinistra	Porte gauche	Left door	Linke Tür	×
4	PACU800019	Posteriore inox	Panneau postérieur inox	Stainless stell back panel	Inox-Rückwand	×
5	PACU800122	Maniglia porta	Poignée porte	Door handle	Türhandgriff	×
6	RTCU800001	Terminale maniglia	Pièce terminale de la poignée	Terminal handle	Griffanschluß	×
7	RTCU700051	Bussola porta	Douille porte	Door bush	Türbuchse	×
8	PABF900104	Cerniera inferiore porta	Charnière inférieure de la porte	Door lower gasket	Untere Türangel	×
9	PACU800067	Porta destra	Porte droit	Right door	Rechte Tür	×
10	PACU800157	Controporta	Contre porte	Counter door	Gegentür	×
11	RTBF800228	Maniglia cestello	Poignée pour panier	Basket handle	Korbhandgriff	×
12	GACU800038	Cerniera superiore sinistra	Charnière supérieure gauche	Left upper hinge	Linke Türangel	×
13	GABF800005	Cruscotto	Panneau de contrôle	Control panel	Stimmbrett	×
14	RTCU900072	Spia gialla	Lampe témoin jaune	Jellow pilot lamp	Gelbe Kontrolleuchtenbiren	×
15	RTCU900290	Spia verde	Lampe témoin vert	Green pilot lamp	Grüne Kontrolleuchtenbirne	×
16	RTCU800060	Manopola termostato	Poignée pour thermostat	Thermostat knob	Thermostatkugelgriff	×
17	RTCU800062	Manopola commutatore	Poignée pour commutateur	Commutator knob	Kommutatorkugelgriff	×
18	RTBF800163	Termostato	Thermostat	Thermostat	Thermostat	×
19	RTBF800161	Commutatore	Commutateur	Commutator	Kommutator	×
20	RTBF800164	Termostato Limit 240°C	Thermostat Limit 240°C	Limit thermostat 240°C	Limit Thermostat 240°C	×
21	GACU800037	Cerniera superiore destra	Charnière supérieure droite	Upper right hinge	Rechte Türangel	×
22	RTBF800021	Gommino	Bouchon en cahutchoc	Rubber cap	Türgummi	×
23	RTBF800226	Vasca olio	Cuve huile	Oil tank	Ölwanne	×
24	RTBF900045	Morsettiera 5 poli	Connection des cables	Terminal board	Klemmbrett 5 polig	×
25	PABF800089	Guida per vasca	Rail pour la cuve huile	Oil tank slide-way	Ölbeckenführung	×
26	GACU800001	Basamento	Soubassement	Basement	Untergestell	×
27	GACU800122	Piedino inox	Pied en acier inox	Stainless steel foot	Inox-Rückwand	×
28	RTTAV00006	Supporto regolatore	Support du regulateur	Regulator support	Reglerhalterung	×
29	PACU800008	Fianco sinistro	Côté gauche	Left side	Rechte Seite	×
30	RTBF800165	Relay	Relay	Relay	Relay	×
31	RTCU800022	Regolatore piedino	Regulateur pied	Foot regulator	Fußregler	×
32	RTBF800219	Rubinetto scarico olio	Robinet de l'huile	Oil tap	Ablafshahn	×
33	ERBF800014	Griglia	Grille	Grate	Rost	×
34	RTBF800010	Cestello	Panier	Basket	Fritierkorb	×
35	RTBF800229	Maniglia coperchio	Poignée couvercle	Cover handle	Deckelgriff	×
36	RTBF800230	Coperchio vasca	Couvercle cuve	Tank cover	Beckenabdeckung	×
37	RTBF800227	Scola cestello	Croc pour panier	Hook for tank	Korbhaken	×
38	RTBF800215	Alzatina	Élévation	Lift	Tafel	×
39	RTBF800220	Prolunge rubinetto	Prolonge du robinet	Tap extention	Hahnverlängerung	×
40	RTBF800009	Cestello	Panier	Basket	Fritierkorb	×
41	GABF800102	Vasca	Cuve	Tank	Wanne	×
42	RTBF800218	Tubo scarico olio	Tuyau de l'huile	Oil pipe	Ölablaßrohr	×
43	RTBF800162	Resistenza elettrica 6000W 240V	Resistance elect. 6000W 240V	Over heating elec. 6000W 240V	Elektr. Widerstand 6000W 240V	×
44	RTBF800221	Maniglia rubinetto	Poignée du robinet	Tap extention	Hahngriff	×
45	PACU800009	Fianco destro	Côté droite	Right side	Rechte Seite	×

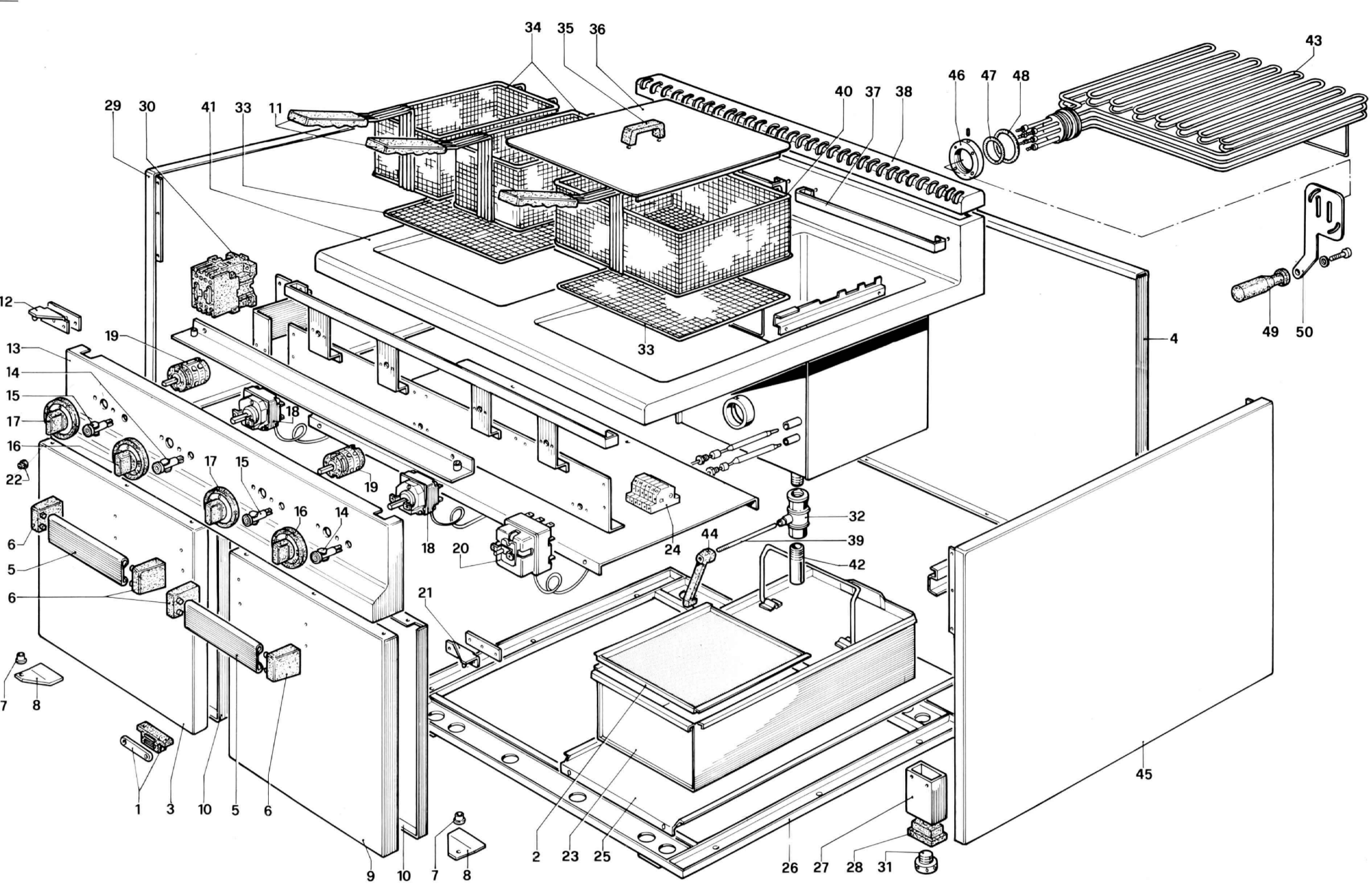

TAV.74/A		Friggitrice elett. EF90	Friteuse électrique	Electric fryer	Elektrische Friteuse	EF90
	Codice	Denominazione	Denominaton	Denominaton	Bezeichnung	
1	RTBF800233	Attacco magnetico	Attaque magnetique	Magnetic connection	Magnetanschluß	×
2	RTBF800225	Filtro vasca olio	Filtre pour la cuve huile	Oil tank filter	Ölbeckenfilter	×
3	PACU800159	Porta sinistra	Porte gauche	Left door	Linke Tür	×
4	PACU800019	Posteriore inox	Panneau postérieur inox	Stainless steel back panel	Inox-Rückwand	×
5	PACU800122	Maniglia porta	Poignée porte	Door handle	Türhandgriff	×
6	RTCU800001	Terminale maniglia	Pièce terminale de la poignée	Terminal handle	Griffanschluß	×
7	RTCU700051	Bussola porta	Douille porte	Door bush	Türbuchse	×
8	PABF900104	Cerniera inferiore porta	Charnière inférieure de la porte	Door lower gasket	Untere Türangel	×
9	PACU800067	Porta destra	Porte droite	Right door	Rechte Tür	×
10	PACU800157	Controporta	Contre porte	Counter door	Gegentür	×
11	RTBF8000312	Maniglia cestello	Poignée pour panier	Basket handle	Korbhandgriff	×
12	GACU800038	Cerniera superiore sinistra	Charnière supérieure gauche	Left upper hinge	Linke Türangel	×
13	GABF800005	Cruscotto	Panneau de contrôle	Control panel	Stimmbrett	×
14	RTCU900072	Spia gialla	Lampe témoin jaune	Yellow pilot lamp	Gelbe kontrolleuchtenbirne	×
15	RTCU900290	Spia verde	Lampe témoin vert	Green pilot lamp	Grüne kontrolleuchtenbirne	×
16	RTCU800060	Manopola termostato	Poignée pour thermostat	Thermostat knob	Thermostatkugelgriff	×
17	RTCU800062	Manopola commutatore	Poignée pour commutateur	Commutator knob	Kommutatorkugelgriff	×
18	RTBF800163	Termostato	Thermostat	Thermostat	Thermostat	×
19	RTBF800161	Commutatore	Commutateur	Commutator	Kommutator	×
20	RTBF800164	Termostato Limit 240°C	Thermostat Limit 240°C	Limit thermostat 240°C	Limit Thermostat 240°C	×
21	GACU800037	Cerniera superiore destra	Charnière supérieure droite	Upper right hinge	Rechte Türangel	×
22	RTBF800021	Gommino	Bouchon en cahutchouc	Rubber cap	Türgummi	×
23	RTBF800292	Vasca olio	Cuve huile	Oil tank	Ölwanne	×
24	RTBF900045	Morsettiera 5 poli	Connection des cables	Terminal board	Klemmbrett 5 polig	×
25	PABF800089	Guida per vasca	Rail pour la cuve huile	Oil tank slide-way	Ölbeckenführung	×
26	GACU800001	Basamento	Soubassement	Basement	Untergestell	×
27	GACU800122	Piedino inox	Pied en acier inox	Stainless steel foot	Inox-Rückwand	×
28	RTTAV00006	Supporto regolatore	Support du regulateur	Regulator support	Reglerhalterung	×
29	PACU800008	Fianco sinistro	Côté gauche	Left side	Rechte Seite	×
30	RTBF800165	Relay	Relay	Relay	Relay	×
31	RTCU800022	Regolatore piedino	Regulateur pied	Foot regulator	Fußregler	×
32	RTBF800219	Rubinetto scarico olio	Robinet de l'huile	Oil tap	Ablaßhahn	×
33	ERBF800014	Griglia	Grille	Grate	Rost	×
34	RTBF800315	Cestello piccolo	Panier	Basket	Fritierkorb	×
35	RTBF800229	Maniglia coperchio	Poignée couvercle	Cover handle	Deckelgriff	×
36	RTBF800317	Coperchio vasca	Couvercle cuve	Tank cover	Beckenabdeckung	×
37	RTBF800227	Scola cestello	Croc pour panier	Hook for tank	Korbhacken	×
38	GACU800014	Griglia camino	Grille de la cheminée	Chimney grate	Schornsteinrost	×
39	RTBF800220	Prolunga rubinetto	Prolonge du robinet	Tap extention	Hahnverlängerung	×
40	RTBF800316	Cestello grande	Panier	Basket	Fritierkorb	×
41	RTBF800313	Vasca	Cuve	Tank	Wanne	×
42	RTBF800218	Tubo scarico olio	Tuyau de l'huile	Oil pipe	Ölablaßrohr	×
43	RTBF800318	Resistenza elettrica 18kW 240V	Resistance elect.18kW 240V	Over heating elec. 18kW 240V	Elektr. Widerstand 18kW 240V	×
44	RTBF800221	Maniglia rubinetto	Poignée du robinet	Tap extention	Hahngriff	×

TAV.74/A						EF90
		Friggitrice elett. EF90	Friteuse électrique	Electric fryer	Elektrische Friteuse	
	Codice	Denominazione	Denominaton	Denominaton	Bezeichnung	
45	PACU800009	Fianco destro	Côté droite	Right side	Rechte Seite	X
46	RTBF800319	Ghiera blocc. resistenza	Bague blocage resistance	Resistance locking nut	Befestigungsmutter Widerstand	X
47	RTBF800320	Anello OR anteriore	Bague OR antérieure	Front O-ring	Vorderer O-ring	X
48	RTBF800321	Anello OR posteriore	Bague OR postérieure	Vack O-ring	Hinterer O-ring	X
49	RTBF800322	Impugnatura leva	Poignée levier	Lever grip	Hebelgriff	X
50	RTBF800323	Leva rotazione	Levier rotation	Rotation lever	Drennebel	X