



ISO 9001
BUREAU VERITAS
Certification



ISO 14001
BUREAU VERITAS
Certification



Applus®
LGA1
Organismo
Notificado
0370

AENOR
Organismo
Notificado
0099



TOLERANCIAS GENERALES: ±0.5 mm

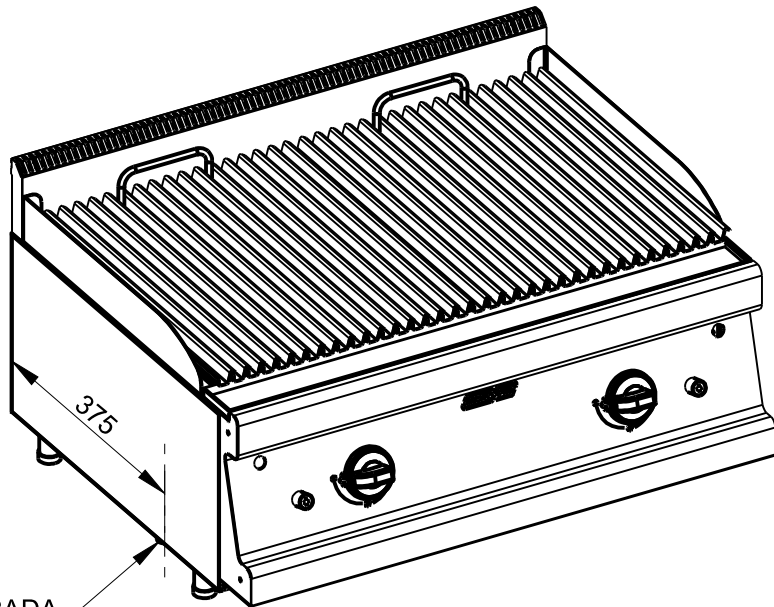
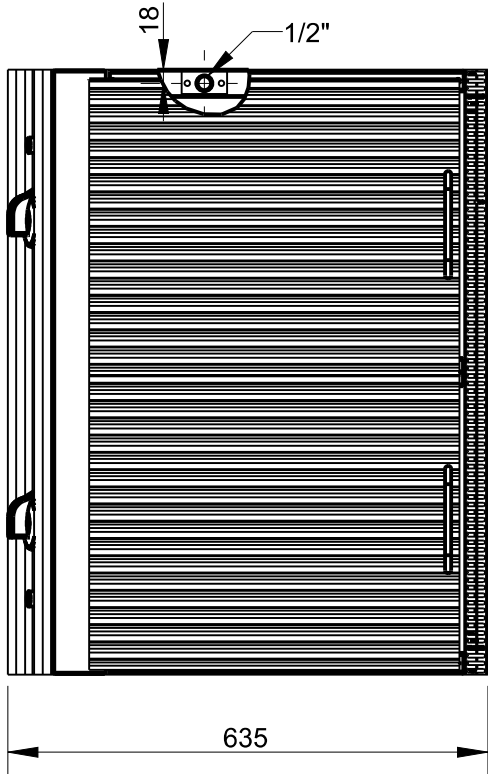
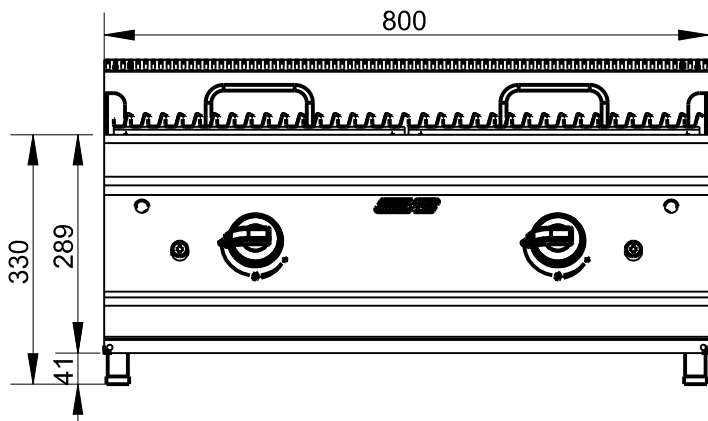
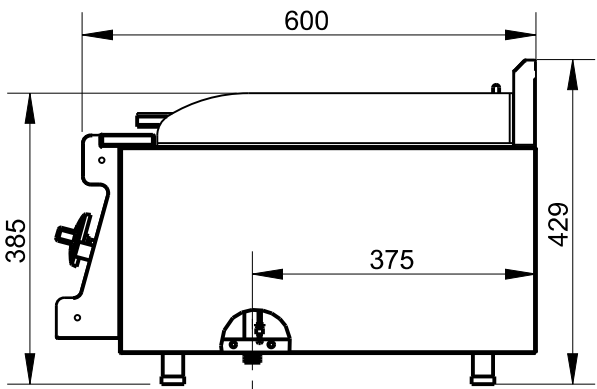

POTENCIA: 10 KW

ATENCIÓN: CUANDO VA MONTADO SOBRE SOPORTE LAS PATAS SE DEBEN SACAR Y ATORNILLAR EL APARATO AL SOPORTE



FAMILIA: COCINAS 2008

FECHA: 03/12/12

MODELO: 3014/2

PESO(Kg): 52.458

DENOMINACION:
BARBACOA SNACK/2 800

ESCALA:
1/10

MATERIAL:
INOX

CODIGO:
30142



Applus®
LGAI
Organismo
Notificado
0370

AENOR
Organismo
Notificado
0099



TOLERANCIAS GENERALES: ±0.5 mm

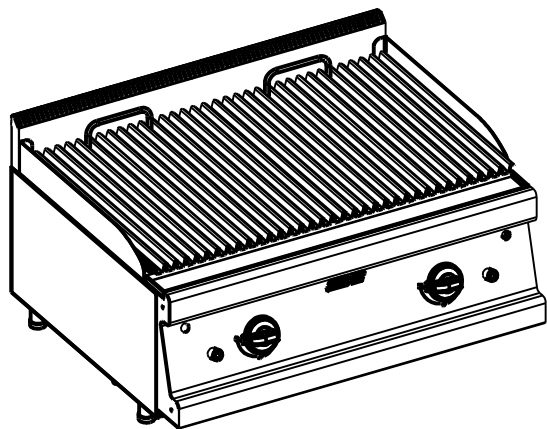

QT	COD	DESCRIPCION
2	3739	ENCENDIDO PIEZOELECTRICO
4	6038	PATA REGULABLE AP. SNACK
1	96108	CEPILLO BARBACOA
1	301340	LAT IZQ SOBRE BBQ/2-600
1	301341	LAT DCHO SOBRE BBQ/2-600
1	301440	SOP CENTRAL PARRILLA BBQ/2-600
1	330613	TRASERO HORNILLO 800
1	350565	FRONTAL INFERIOR 800
1	440449	CANAL PLANCHA 800
2	3013012P	PARRILLA CARNE BBQ/2 SNACK
1	3014162M	DEFL MONTADO/2 800X600/750
1	3014392C	CONJ. FRONTAL BBQ/2 SNACK 800
1	330422C	CONJ. PETO SNK CORTO 800
1	330608M	CONJ.LAT.SUPERIOR DCH.600
1	330609M	CONJ.LAT.SUPERIOR IZQ.600
1	330685PC	BATERIA COMP.COCINA 2F. 800
2	340173PM	CONJUNTO MANDO A GAS
2	C5816289M	CONJUNTO GRIFO EJE LARGO
4	C9500009	PIEDRA VOLCÁNICA (BOLSA 3KG.)
2	T10030	TUBO AL D.10 L.300

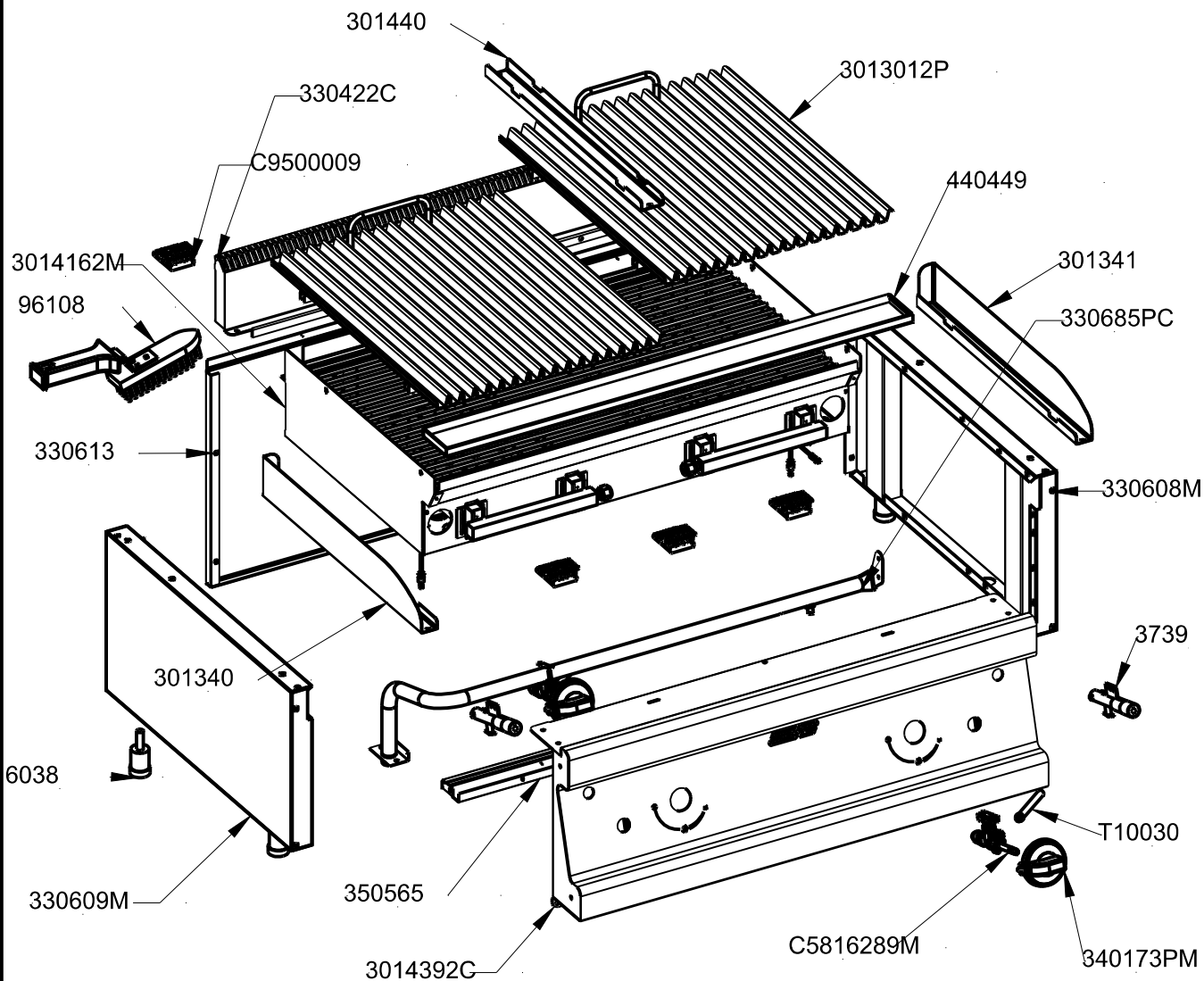

FAMILIA: COCINAS 2008

FECHA: 03/12/12

MODELO: 3014/2

PESO(Kg): 52.458

DENOMINACION:
BARBACOA SNACK/2 800

ESCALA:
1/10

MATERIAL:
INOX

CODIGO:
30142



Applus®
LGAI
Organismo
Notificado
0370

AENOR
Organismo
Notificado
0099



TOLERANCIAS GENERALES: ±0.5 mm

QT	COD	DESCRIPCION	FAB.	MATERIAL	DATA	PESO
4	300184	AIREADOR QUEMADOR	SÍ	INOFER 0.8	09/06/09	0.023
8	300187	REGISTRO TRASERO QUEMADOR	SÍ	INOFER 1.2	05/12/08	0.044
2	300388	CORRELLAMAS	SÍ	INOFER 0.8	05/02/09	0.106
2	300399	TAPA 20X20 C/AGUJERO D.12	SÍ	FE 1.2	02/09/08	0.003
1	301340	LAT IZQ SOBRE BBQ/2-600	SÍ	INOX 2	05/10/12	0.821
1	301341	LAT DCHO SOBRE BBQ/2-600	SÍ	INOX 2	05/10/12	0.821
2	301399	TAPA 20X20	SÍ	FE 1.2	02/09/08	0.004
1	301416	DEFLECTOR BBQ 800X600/750	SÍ	INOFER 0.8	10/06/09	3.745
1	301440	SOP CENTRAL PARRILLA BBQ/2-600	SÍ	INOX 2	10/10/12	0.509
1	301578	TAPETA DCH.PETO CORTO SNK	SÍ	i441 1.2	09/10/07	0.072
1	301579	TAPETA IZQ.PETO CORTO SNK	SÍ	i441 1.2	09/10/07	0.072
1	330194	PLETINA LATERAL BATERÍA	SÍ	FE 1.5	03/11/08	0.012
1	330294	PLETINA BASE BATERÍA	SÍ	FE 1.5	03/11/08	0.021
1	330422	PETO SOBRE SNACK 800 CORTO	SÍ	INOX 1.2	10/12/08	1.206
1	330608	LATERAL SUPERIOR 600 DCHO	SÍ	i441 0.8	29/10/08	1.456
1	330609	LATERAL SUPERIOR 600 IZQ	SÍ	i441 0.8	29/10/08	1.456
1	330613	TRASERO HORNILLO 800	SÍ	i441 0.8	11/12/08	1.923
3	330675	REFUERZO PATA	SÍ	GALVA 1.5	11/12/08	0.429
1	350565	FRONTAL INFERIOR 800	SÍ	i441 0.8	15/06/10	0.394
2	362176	SOPORTE-ADAPT.PIEZO SIT-JUNK	SÍ	i441 0.8	18/05/11	0.035
1	440449	CANAL PLANCHA 800	SÍ	INOFER 0.8	09/02/10	0.584
1	3001782	TAPETA LAT.DCH.FR.BBQ/2 SNACK 400	SÍ	INOFER 1.2	14/06/11	0.143
1	3001792	TAPETA LAT.DCH.FR.BBQ/2 SNACK 400	SÍ	INOFER 1.2	06/06/11	0.154
1	3014392	FRONTAL MANDOS BBQ/2 SNACK 800	SÍ	INOX 1.2	27/11/12	4.222
1	3306751	REFUERZO PATA C/ENCAJE BATERIA	SÍ	GALVA 1.5	09/01/09	0.361
1	3014162M	DEFL MONTADO/2 800X600/750	SÍ	INOX	03/12/12	10.981
1	3014392C	CONJ. FRONTAL BBQ/2 SNACK 800	SÍ	INOX	27/11/12	4.635
1	330422C	CONJ. PETO SNK CORTO 800	SÍ	INOX	10/12/08	1.367
1	330608M	CONJ.LAT.SUPERIOR DCH.600	SÍ	INOX	17/01/11	2.330
1	330609M	CONJ.LAT.SUPERIOR IZQ.600	SÍ	INOX	17/01/11	2.261
2	TESTA140	ANGULO TESTATINA 140	SÍ	INOX 0.6	29/08/07	0.016
6	TESTA35	ANGULO TESTATINA 35	SÍ	INOX 0.6	29/08/07	0.004
2	TESTA70	ANGULO TESTATINA 70	SÍ	INOX 0.6	29/08/07	0.008
4	1014	REMACHE ROSCADO M-10	NO	ZN	17/12/09	0.008
2	2175	CABLE PIEZO L=760	NO	FIBRA/CU	21/06/12	0.009
2	3705	SOPORTE SUPERIOR	NO	FE	03/02/09	0.005
2	3739	ENCENDIDO PIEZOELECTRICO	NO	INOX	29/04/11	0.098
2	3781	TUERCA M16X1.5 D.10	NO	LATON	05/09/08	0.015
2	3782	BICONO D.10 LATON	NO	LATON	01/01/09	0.001
2	3786	SOPORTE INFERIOR	NO	FE	03/02/09	0.009
4	6038	PATA REGULABLE AP.SNACK	NO	BAQUELITA	01/12/93	0.068
2	31691	BRIDA 1/2" SABAF	NO	FE ZN	13/02/09	0.011
1	96108	CEPILLO BARBACOA	NO	INOX	01/01/01	0.220
2	330189	MANGUITO M16X1.5 TUBO D.10	NO	FE	22/09/08	0.007



FAMILIA: COCINAS 2008

FECHA: 03/12/12

MODELO: 3014/2

PESO(Kg): 52.458

DENOMINACION:
BARBACOA SNACK/2 800

ESCALA:
1/10

MATERIAL:
INOX

CODIGO:
30142



Applus®
LGA1
Organismo
Notificado
0370

AENOR
Organismo
Notificado
0099



TOLERANCIAS GENERALES: ±0.5 mm

4	447148	GUIA REFUERZO PARRILLA CARNE 400	NO	FE 2	04/03/10	0.231
4	300187P	QUEMADOR TUBULAR D.40 L.400	NO	INOX	05/08/09	0.424
2	3013012P	PARRILLA CARNE BBQ/2 SNACK	NO	FE	08/06/11	5.948
34	3013482P	CANAL PARR. CENT.BBQ/2 600/750	NO	FE 1.5	08/06/11	0.264
2	3013512P	TIRADOR PARRILLA BBQ/2 SNACK	NO	FE D.8	08/06/11	0.085
1	301402P	PARRILLA LAVA BBQ 800X600	NO	FE PAV.	14/12/10	4.370
1	330685P	BATERIA 2F 800	NO	FE 1/2"	20/04/11	0.739
1	330685PC	BATERIA COMP.COCINA 2F. 800	NO	FE 1/2" ZN	20/04/11	0.785
2	340172P	EMBELLECEDOR MANDO GAS/ELECT.	NO	ABS	10/12/07	0.012
2	340173P	MANDO COCINA GAS 2008	NO	BAQUELITA	10/12/07	0.064
2	340173PM	CONJUNTO MANDO A GAS	NO	BAQUELITA	10/12/07	0.076
2	3786M	CONJUNTO TERMOPAR-BUJIA	NO	VARIOS	03/02/09	0.055
2	447175P	REFUERZO PAR.BBQ BAR	NO	FE D.10	08/06/11	0.910
2	493086P	COLECTOR HGR	NO	FE	07/10/08	0.124
2	493086PC	COLECTOR 2 SALIDAS HGR	NO	FE ZN.	07/10/08	0.000
4	C1061243	TORNILLO M-4X25 DIN933 ZN	NO	FE ZN	12/02/09	0.003
2	C3704	TORNILLO ZN SIT	NO	FE ZN	03/02/09	0.004
2	C5811809	TERMOPAR M8 C/LISA L.850	NO	CU	03/02/09	0.022
4	C5812649	INY. D.110 GLP QUEM. L.400	NO	LATON	01/01/09	0.012
4	C5812669	INY. D.160 GN QUEM.L.400	NO	LATON	01/01/09	0.012
2	C5815559	BICONO D.8 SABAF	NO	LATON	13/02/09	0.001
2	C5815569	TUERCA 1/4" D.8 SABAF	NO	FE ZN	13/02/09	0.003
2	C5816289	GRIFO COCINA ECO +15MM	NO	LATON	11/02/09	0.102
2	C5816289M	CONJUNTO GRIFO EJE LARGO	NO	LATON	11/02/09	0.124
1	C5816309	TOMA DE PRESIÓN PARA BATERIA	NO	LATON	31/03/11	0.013
2	C5820109	BUJIA	NO	CER	22/10/02	0.007
4	C9500009	PIEDRA VOLCÁNICA (BOLSA 3KG.)	NO	P.V.	23/12/08	3.000
2	T10030	TUBO AL D.10 L.300	NO	AL 99.7%	13/05/09	0.031



FAMILIA: COCINAS 2008

FECHA: 03/12/12

MODELO: 3014/2

PESO(Kg): 52.458

DENOMINACION:
BARBACOA SNACK/2 800

ESCALA:
1/10

MATERIAL:
INOX

CODIGO:
30142



Applus®
LGA1
Organismo
Notificado
0370

AENOR
Organismo
Notificado
0099



TOLERANCIAS GENERALES: ±0.5 mm

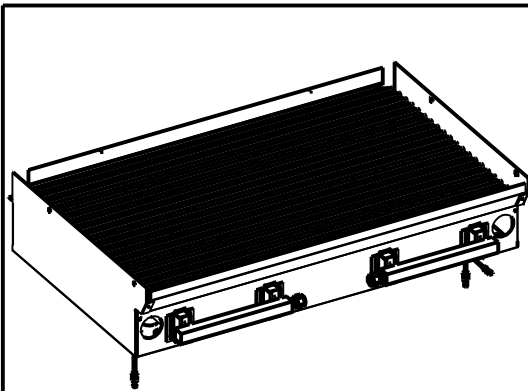

QT	COD	DESCRIPCION
4	300184	AIREADOR QUEMADOR
2	3782	BICONO D.10 LATON
2	493086PC	COLECTOR 2 SALIDAS HGR
2	3786M	CONJUNTO TERMPAR-BUJIA
2	300388	CORRELLAMAS
1	301416	DEFLECTOR BBQ 800X600/750
4	C5812649	INY. D.110 GLP QUEM. L.400
4	C5812669	INY. D.160 GN QUEM.L.400
1	301402P	PARRILLA LAVA BBQ 800X600
4	300187P	QUEMADOR TUBULAR D.40 L.400
8	300187	REGISTRO TRASERO QUEMADOR
2	3781	TUERCA M16X1.5 D.10

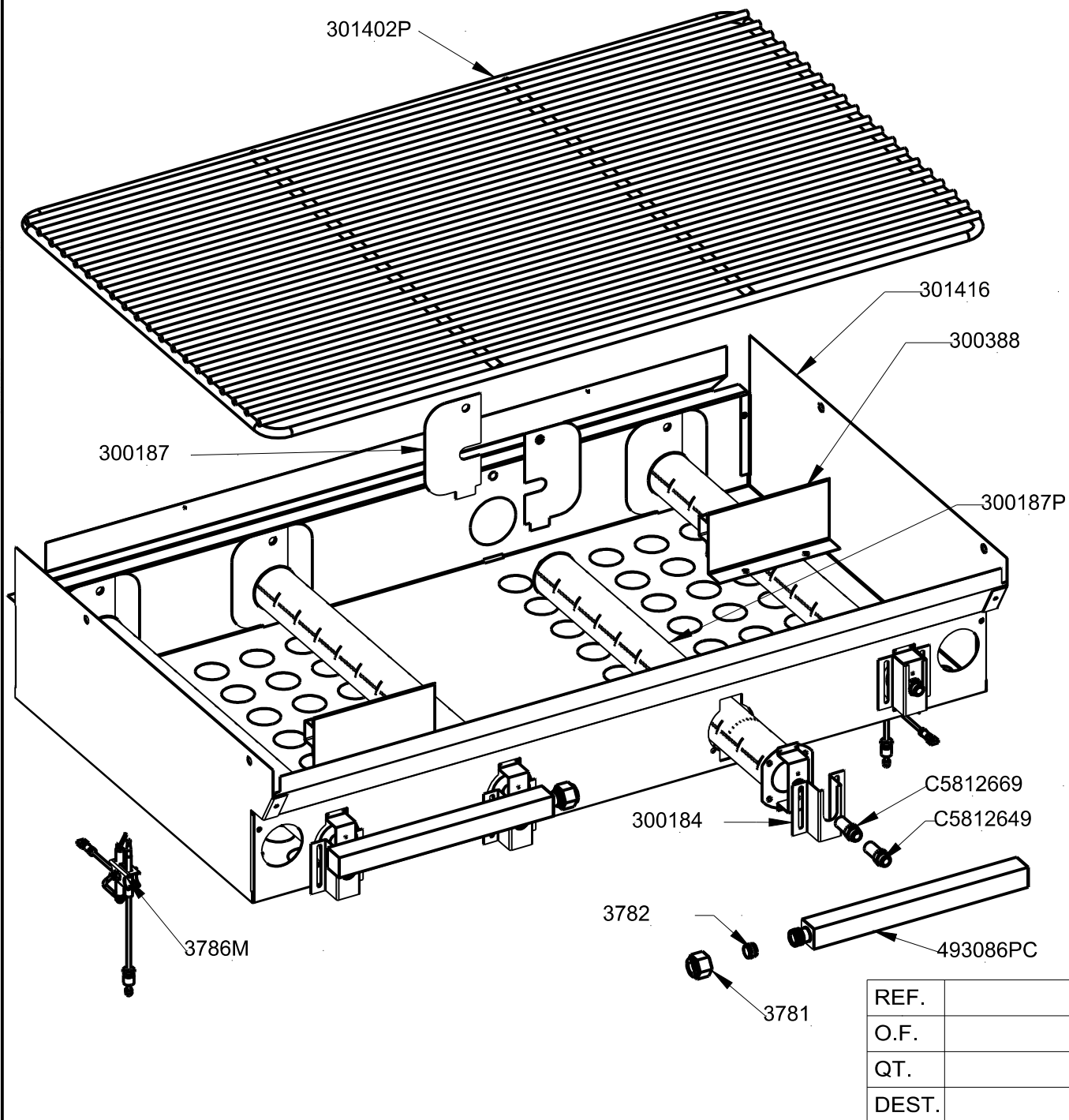

REF.	
O.F.	
QT.	
DEST.	



FAMILIA: COCINAS 2008

FECHA: 03/12/12

MODELO: 3014/2

PESO(Kg): 10.981

DENOMINACION:
DEFL MONTADO/2 800X600/750

ESCALA:
1/5

MATERIAL:
INOX

CODIGO:
3014162M



Applus®
LGAI
Organismo
Notificado
0370

AENOR
Organismo
Notificado
0099



TOLERANCIAS GENERALES: ±0.5 mm

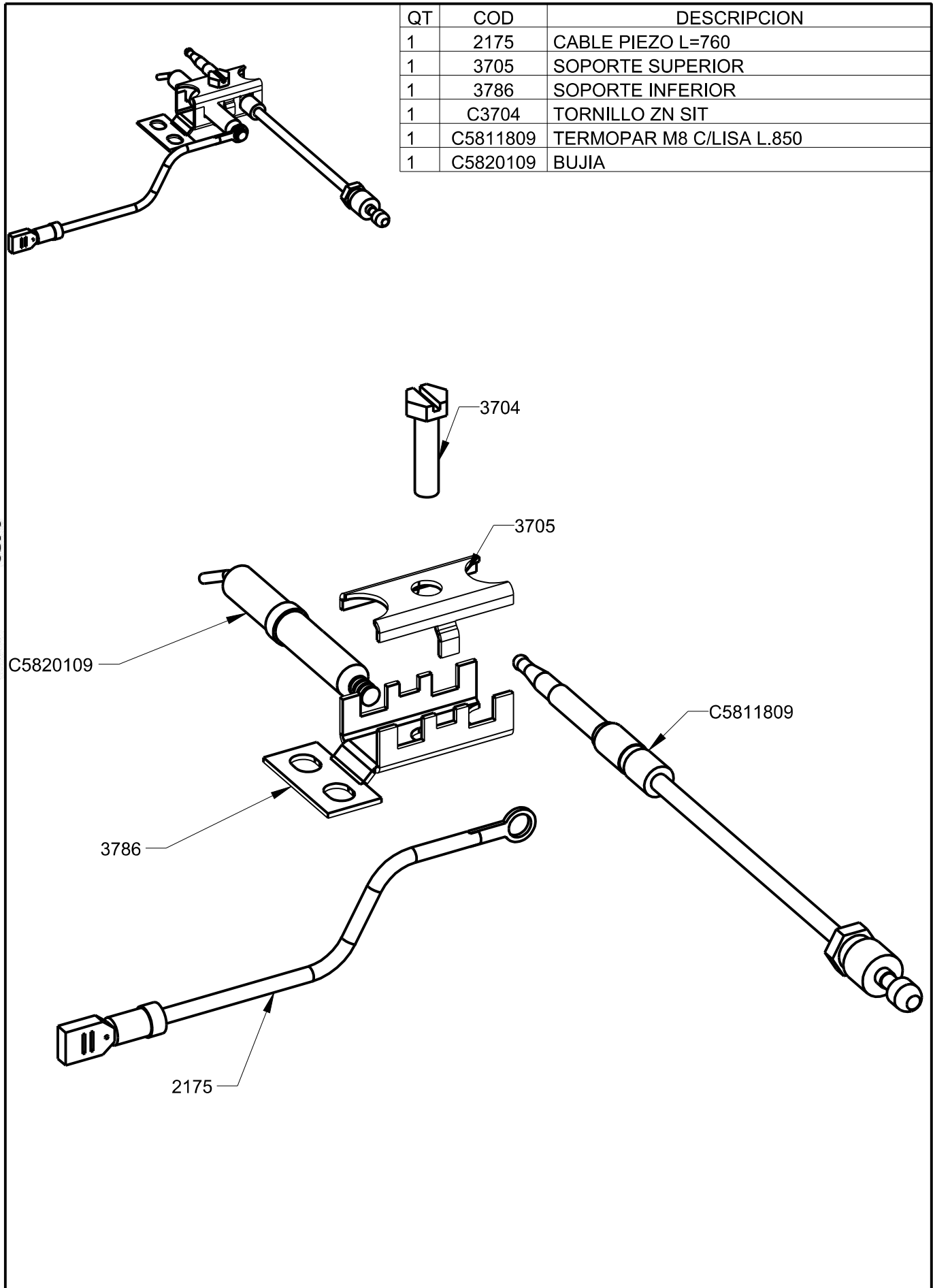

QT	COD	DESCRIPCION
1	2175	CABLE PIEZO L=760
1	3705	SOPORTE SUPERIOR
1	3786	SOPORTE INFERIOR
1	C3704	TORNILLO ZN SIT
1	C5811809	TERMOPAR M8 C/LISA L.850
1	C5820109	BUJIA

	FAMILIA: COCINAS 2008	FECHA: 03/02/09
	MODELO: 4901	PESO(Kg): 0.055
DENOMINACION: CONJUNTO TERMOPAR-BUJIA	ESCALA: 1/1	MATERIAL: VARIOS
		CODIGO: 3786M



Applus®
LGA1
Organismo
Notificado
0370

AENOR
Organismo
Notificado
0099



TOLERANCIAS GENERALES: ±0.5 mm

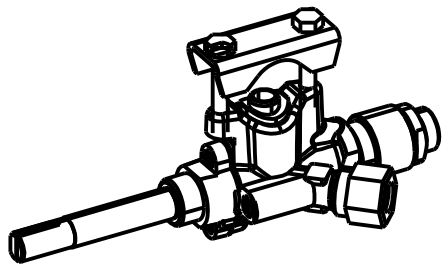

ESCALA 1/2

QT	COD	DESCRIPCION
1	31691	BRIDA 1/2" SABAF
2	C1061243	TORNILLO M-4X25 DIN933 ZN
1	C5815559	BICONO D.8 SABAF
1	C5815569	TUERCA 1/4" D.8 SABAF
1	C5816289	GRIFO COCINA ECO +15MM

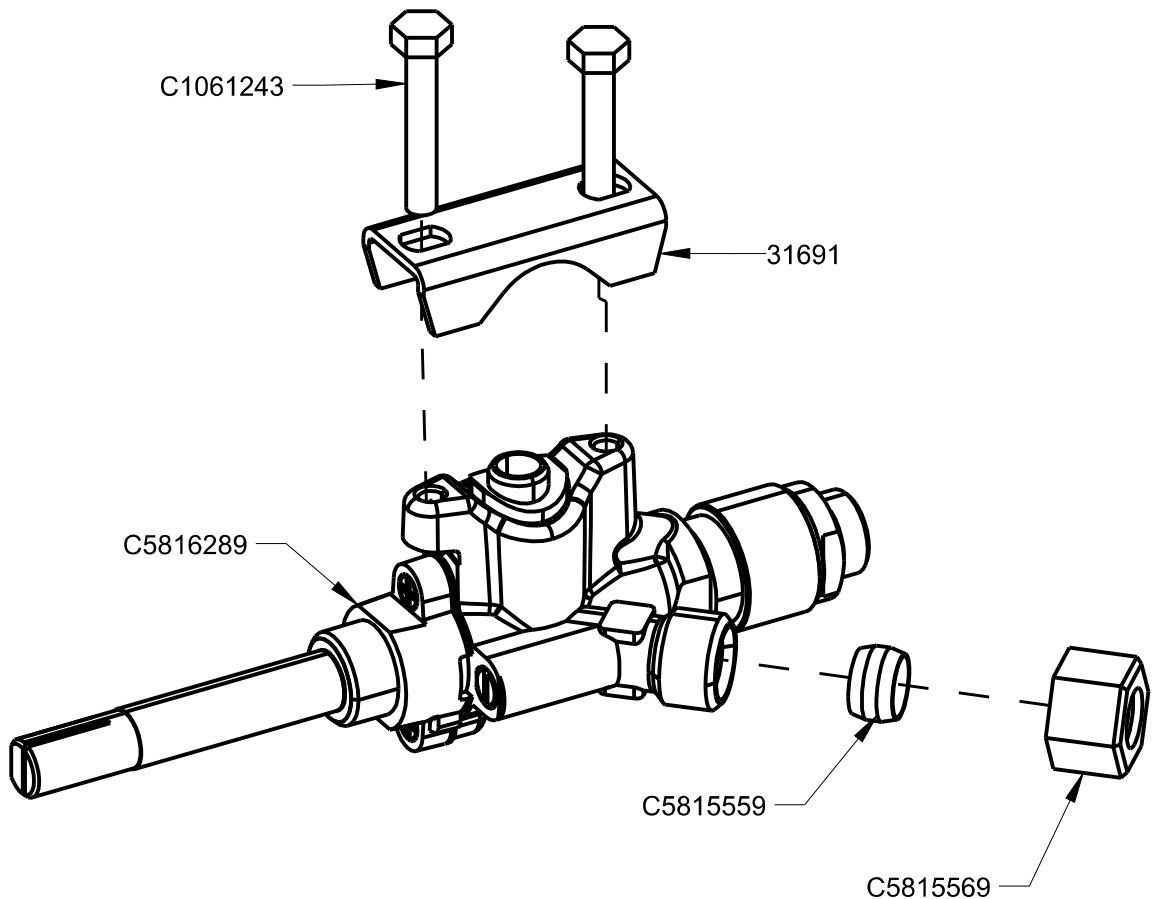
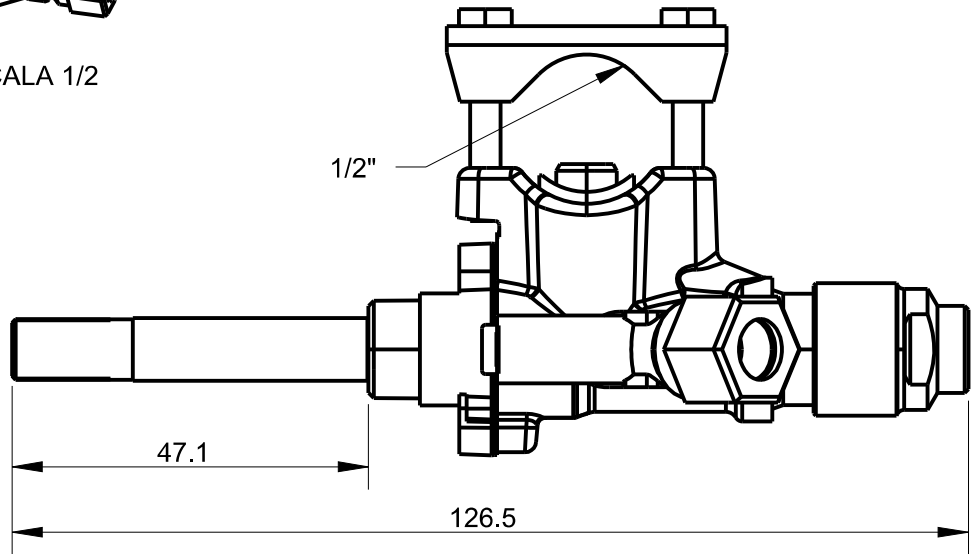

FAMILIA: COCINAS 2008

FECHA: 11/02/09

MODELO: 3300

PESO(Kg): 0.124

DENOMINACION:
CONJUNTO GRIFO EJE LARGO

ESCALA:
1/1

MATERIAL:
LATON

CODIGO:
C5816289M