

TAV.35		Struttura GC45	Structure	Structure	Struktur	GC45	GC45 DIN
	Codice	Denominazione	Denominaton	Denominaton	Bezeichnung		
1	RTCU800001	Terminale maniglia	Terminal poignée	Handle terminal	Griffanschluss	x	x
2	PACU800122	Maniglia porta armadio	Poignée porte de l'armoire	Cupboard door handle	Handgriff	x	x
3	PACU800067	Porta armadio	Porte de l'armoire	Cupboard door	Schranktür	x	x
4	MPLAN40N00	Lana S/clima	Laine pour préserver la chaleur	Insulating panel to keep the temp.	Isoliermaterial	x	x
5	PACU800157	Controporta	Contre porte	Counter door	Gegentür	x	x
6	RTBF800016	Attacco magnetico	Attaque magnetique	Magnet connection	Magnetanschluß	x	x
7	PACU800037	Cerniera superiore destra	Charnière superieure	Upper hinge	Rechte Türangel	x	x
8	PACU700194	Piastrina fissaggio cerniera	Eguerre fixage charnière	Bracket to fix hinge	Scharnierbefestigungsplättchen	x	x
9	RTBF800021	Gommino porta	Bouchon porte	Door rubber cap	Türgummi	x	x
10	RTCU700051	Bussola porta	Douille porte	Door bush	Türbuchse	x	x
11	PABF900104	Cerniera inferiore	Charnière inférieure	Lower hinge	Untere Türangel	x	x
12	PABF800133	Telaio facciata GC45	Chassis pour panneau antérieure GC45	Front panel frame GC45	Vorderwandrahmen	x	x
13	GACU800053	Basamento	Soubassement	Base	Untergestell	x	x
14	GACU800122	Piedino inox	Pied inox	Inox foot	Inox-Fuß	x	x
15	RTTAV00006	Supporto regolatore	Support du regulateur	Regulator support	Reglerhalterung	x	x
16	RTCU800022	Regolatore piedino	Regulateur pied	Foot regulator	Fußregler	x	x
17	PABF800142	Squadretta fissaggio bruciatore	Eguerre fixage brûleur	Bracket to fix burner	Brennerhaltewinkel	x	x
18	PABF800262	Fondo camera combustione	Sole chambre de combustion	Combustion chamber bottom	Brennkammerboden	x	x
19	PABF800264	Contorno camera combustione	Périmètre chambr de combustion	Combustion chamber perimeter	Brennkammerrand	x	x
20	RTBF800005	Pannello isolante laterale	Panneau isolant	Insulating panel	Isoliermaterialverkleidung	x	x
21	PABF800144	Fermo laterale isolante	Arrêt lateral pour panneau isolant	Lock for insulating panel	Isoliermaterialverkleidung	x	x
22	RTCU800009	Fianco destro	Côté droite	Right side	Rechte Seite	x	x
23	GABF800067	Cruscotto	Panneau de contrôle	Control panel	Stimmbrett	x	x
24	PABF800138	Contro cruscotto	Contre panneau de contrôle	Counter control panel	Gegenstimmbrett	x	x
25	PABF800143	Fermo anteriore isolante	Arrêt panneau isolant	Lock for insulating panel	Isoliermaterialverkleidung	x	x
26	RTBF800008	Pannello isolante anteriore	Panneau isolant	Insulating panel	Isoliermaterialverkleidung	x	x
27	PABF800131	Facciata camera combustione	Panneau antér. chambre de combustion	Combustion chamber face	Brennkammervorderwand	x	x
28	PACU800008	Fianco sinistro	Côté gauche	Left side	Linke Seite	x	x
29	GABF800065	Vasca GC45	Cuve	Bowl	Wanne	x	x
30	GABF800070	Fondo forato	Fond perforé	Perforated bottom	Gelochter Boden	x	x
31	GACU800013	Griglia caminetto	Grille cheminée	Chimney grate	Schornsteinrost	x	x
32	PACU800183	Caminetto superiore	Cheminée supérieure	Upper chimney	Oberer Schornstein	x	x
33	PABF800259	Parete post. caminetto interno	Cheminée intérieure	Internal chimney	Innenschornstein	x	x
34	PACU800186	Fondello caminetto superiore	Sole cheminée supérieure	Upper chimney bottom	Schornsteinbodenscheibe	x	x
35	PACU800024	Posteriore inox	Panneau postérieure	Back panel	Inox-Rückwand	x	x
36	PABF800127	Schienale interno GC45	Panneau postérieure	Internal back	Innenriemchen	x	x
37	GABF800066	Conogliatore fumi	Convoyer de fumées	Smoke convoyer	Rauchförderer	x	x
38	PABF800095	Squadretta fissaggio cruscotto	Eguerre fixage panneau de contrôle	Bracket to fix control panel	Steuertafel	x	x
39	PABF800260	Parete anteriore caminetto interno	Paroi cheminée intérieure	Wall for internal chimney	Innenschornstein	x	x

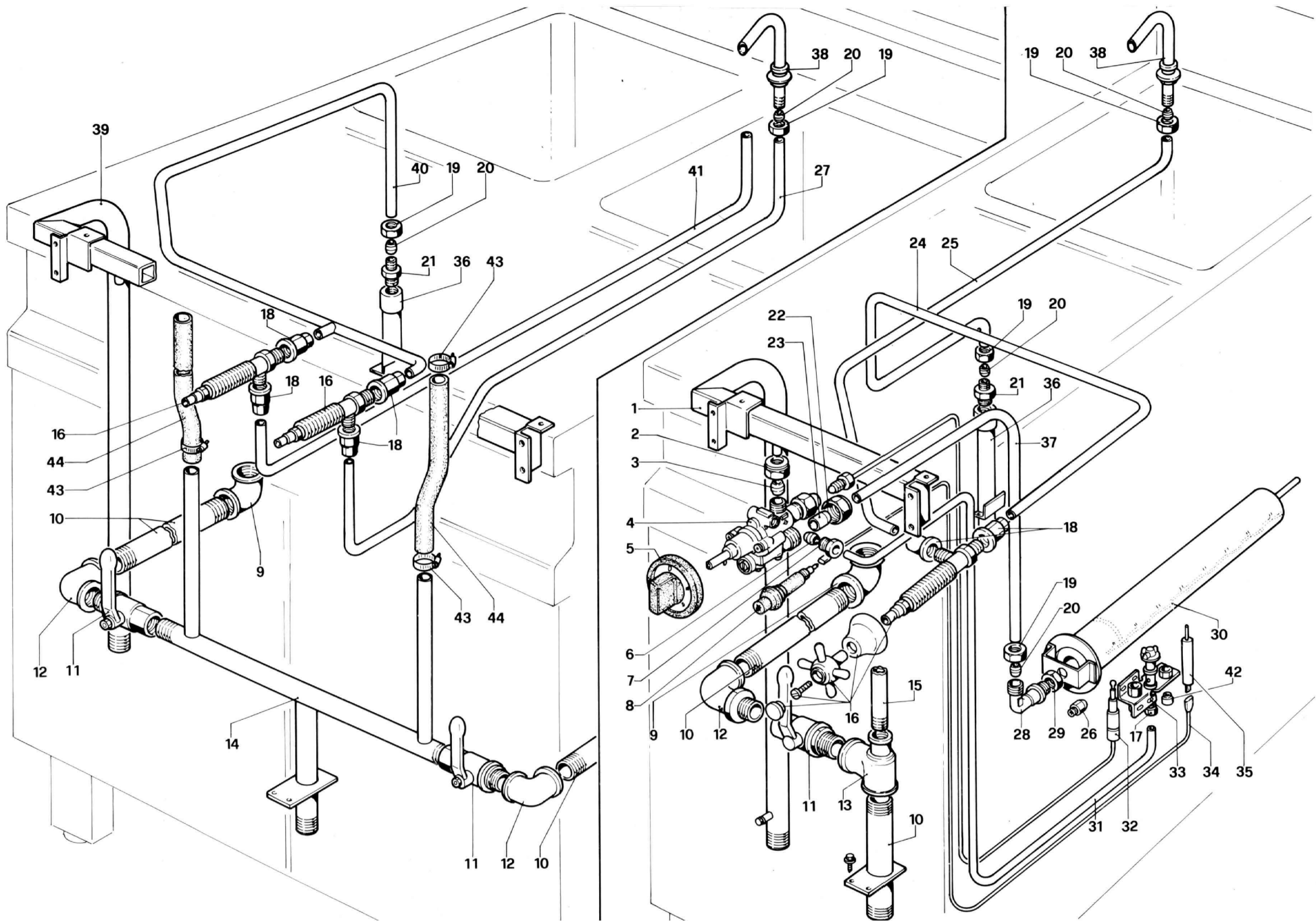

TAV. 37		Impianto gas GC45/902V	Equipements pour gaz	Gas system equipment	Gasanlage	GC45	GC902V
	Codice	Denominazione	Denominaton	Denominaton	Bezeichnung		
1	RTBF800019	Rampa gas	Collecteur gaz	Gas collector	Speiserampe	x	x
2	RTCU900015	Calotta fissaggio rubinetto	Ecrou pour robinet	Nut to fix tap	Mutter für Hahn	x	x
3	RTCU900014	Bicono Ø 12	Bicone pour tuyau Ø 12	Bicone for pipe Ø 12	Zweikegel Ø 12	x	x
4	RTCU900011	Rubinetto valvolato	Robinet avec sécurité	Tap with valve	Hahn mit Ventil	x	x
5	RTCU800014	Manopola rubinetto valvolato	Bouton pour robinet avec sécurité	Knob for tap with valve	Hahnkugelgriff	x	x
6	RTCU900134	Bicono per tubo Ø 4	Bicone pour tuyau Ø 4	Bicone for pipe Ø 4	Zweikegel Ø 4	x	x
7	RTCU900133	Calotta per tubo Ø 4	Ecrou pour tuyau Ø 4	Nut for pipe Ø 4	Mutter für Schlauch Ø 4	x	x
8	RTCU700020	Accenditore piezo	Allumage piezo	Piezo lighting	Piezoelektrischer Anzünder	x	x
9	RTBF800070	Gomito 1"	Raccord 1"	Elbow 1"	Kniestück 1"	x	x
10	RTBF800067	Tubo scarico acpua	Tube de decharge de l'eau	Water discharge pipe	Wasserablassrohr	x	x
11	RTBF800073	Rubinetto scarico	Robinet de decharge	Water discharge tap	Ablasshahn	x	x
12	RTBF800072	Gomito 1"	Raccord 1"	Elbow 1"	Kniestück 1"	x	x
13	RTBF800116	Raccordo 1" - 1/2"	Raccord 1" - 1/2"	Fitting 1" - 1/2"	Anschlussstück 1" - 1/2"	x	
14	RTBF800068	Tubo scarico acpua	Tube de decharge de l'eau	Water discharge pipe	Wasserablassrohr		x
15	RTBF800115	Tubo scarico troppo pieno	Tube de decharge de l'eau	Water discharge pipe	Wasserablassrohr	x	x
16	RTCP800018	Rubinetto acpua	Robinet de l'eau	Water tap	Wasserhahn	x	x
17	RTCP800037	Calotta per tubo Ø 4	Ecrou pour tuyau Ø 4	Nut for pipe Ø 4	Mutter für Schlauch Ø 4	x	x
18	RTBF800126	Niples per tubo Ø 10	Niples pour tuyau Ø 10	Nipples for piep Ø 10	Nippel für Schlauch Ø 10	x	x
19	RTCU900013	Calotta per tubo Ø 10	Ecrou pour tuyau Ø 10	Bicone for pipe Ø 10	Mutter für Schlauch Ø 10	x	x
20	RTCU900012	Bicono per tubo Ø 10	Bicone pour tuyau Ø 10	Bicone for pipe Ø 10	Zweikegel Ø 10	x	x
21	RTCU900132	Niples 1/2" - 3/8"	Niples 1/2" - 3/8"	Nipples 1/2" - 3/8"	Nippel 1/2" - 3/8"	x	x
22	RTCU900017	Calotta Ø 10 per rubinetto	Ecrou Ø 10 pour robinet	Nut Ø 10 for tap	Mutter für Schlauch Ø 10	x	x
23	RTCU900016	Bicono Ø 10 per rubinetto	Bicone Ø 10 pour robinet	Bicone Ø 10 for tap	Zweikegel Ø 10	x	x
24	PABF800153	Tubo alimentazione vasca	Tuyau alimentation cuve	Bowl feeding pipe	Wannenversorgungsrohr	x	
25	PABF800151	Tubo carico acpua	Tuyau distribution eau	Water feeding pipe	Versorgungsrohr	x	
26	RTCU900128	Iniettore GPL Ø 160	Injecteur GPL Ø 160	Injector LPG Ø 160	Flüssiggaseinspritzer Ø 160	x	x
26	RTCU900282	Iniettore gas metano Ø 245	Injecteur methane Ø 245	Methane injector Ø 245	Methangaseinspritzer Ø 245	x	x
27	PABF800150	Tubo carico acpua vasca destra	Tuyau distribution eau	Water feeding pipe	Wannenversorgungsrohr		x
28	RTCU900006	Supporto iniettore	Support injecteur	Injector support	Einspritztür	x	x
29	RTCU900005	Contradado	Contre-écrou	Lock nut	Gegenmutter	x	x
30	RTBF800048	Brucciato	Brûleur	Burner	Brenner	x	x
31	PABF800157	Tubo alimentazione pilota	Tuyau alimentation veilleuse	Pilot pipe	Pilotbrennerrohr	x	x
32	RTCU900060	Termocoppia cm. 75	Thermocouple cm. 75	Thermocouple cm. 75	Thermoemlemt 75 cm.	x	x
33	RTCU900007	Corpo pilota	Veilleuse	Pilot	Pilotbrenner	x	x
34	RTBF700038	Cavo accensione	Cable d'allumage	Lighting cable	Zündkabel	x	x
35	RTCU900010	Candela accensione	Électrode bugie ronde	Round spark	Zündkerze	x	x
36	GABF800035	Tubo carico acpua	Tuyau distribution eau	Water feeding pipe	Versorgungsrohr	x	x
37	PABF800156	Tubo alimentazione bruciatore	Tube alimentation brûleur	Burner feeding pipe	Brennerversorgungsrohr	x	x
38	RTBF800041	Erogatore acpua	Distribution pour l'eau	Water distributor	Wasserversorger	x	x
39	RTBF800074	Ass. Rampa	Collecteur	Collector	Speiserampe		x
40	PABF800152	Tubo alimentazione rubinetto	Tube alimenation robinet	Tap feeding pipe	Hahnversorgungsrohr		x
41	PABF800149	Tubo carico acpua vasca sinistra	Tuyau distribution eau	Water feeding pipe	Wannenversorgungsrohr		x

TAV. 37		Impianto gas GC45/902V	Equipements pour gaz	Gas system equipment	Gasanlage	GC45	GC902V
Codice	Denominazione	Denominaton	Denominaton	Bezeichnung			
42	RTCU900216	Ugello pilota Ø 030 per GPL	Injecteur GPL Ø 030	Injector LPG Ø 030	Flüssiggaseinspritzer Ø 30	X	X
42	RTCU900008	Ugello pilota Ø 051 per gas metano	Injecteur methane Ø 051	Methane injector Ø 051	Methangaseinspritzer Ø 051	X	X
43	RTBF800171	Fascetta metallica	Collier métallique	Metal clamp	Schelle		X
44	MPGOM21T00	Tube in gomma	Tube en caoutchouc	Hydraulic pipe	Gummischlauch		X