



Applus®
LGA1
Organismo
Notificado
0370

AENOR
Organismo
Notificado
0099

FUNDADA EN 1878
MAS BAGA
GRANDES COCINAS

EURAST

mac-fin

TOLERANCIAS GENERALES: ± 0.5 mm

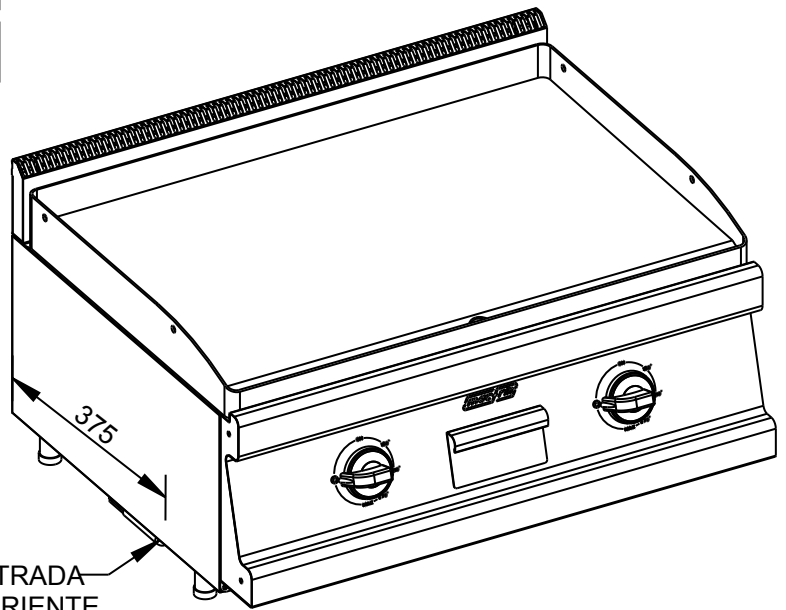
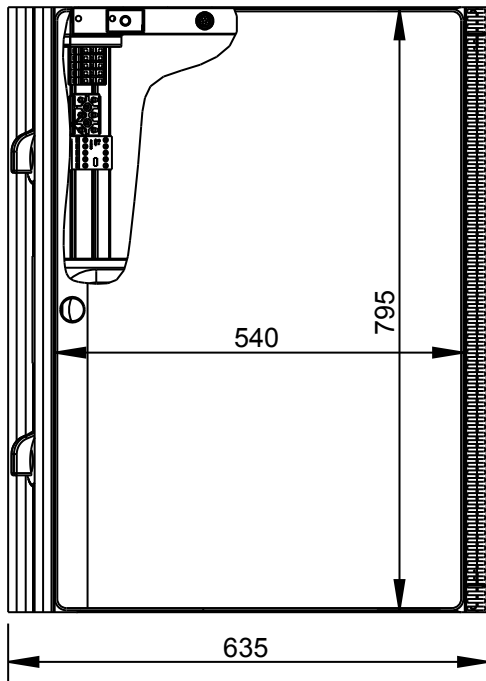
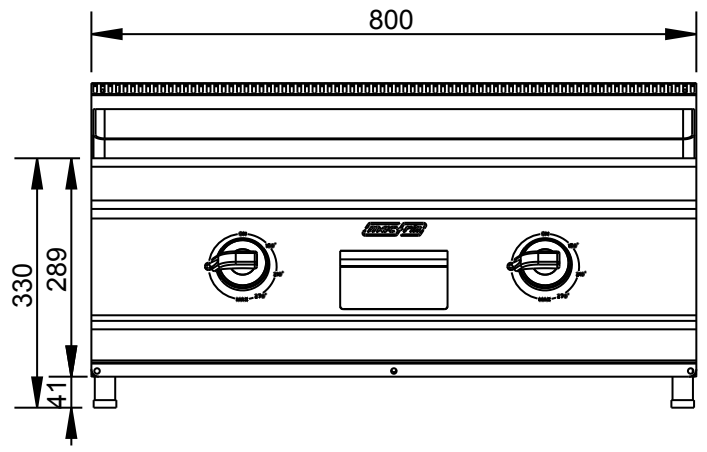
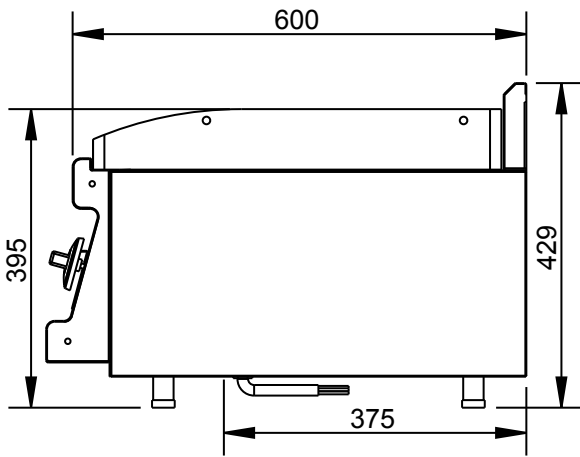

ENTRADA
CORRIENTE

POTENCIA: 8000W-400/III



FAMILIA: COCINAS 2008

FECHA: 01/08/11

MODELO: 3009 - SP8CE - SFCME

PESO(Kg): 71.836

DENOMINACION:
PLANCHA SNACK ELEC. 800

ESCALA:
1/10

MATERIAL:
INOX

CODIGO:
3009



Applus®
LGA1
Organismo
Notificado
0370

AENOR
Organismo
Notificado
0099



TOLERANCIAS GENERALES: ± 0.5 mm

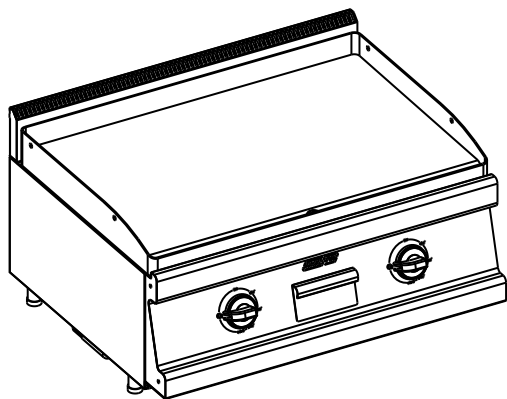

QT	COD	DESCRIPCION
1	2023	PRENSAESTOPA PG-16 INOX
2	2191	CABLE MANGUERA 5X4 (m.l.)
2	2221	TERMOSTATO 320°
4	6038	PATA REGULABLE AP.SNACK
1	300133	RAMPA CAÍDA ACEITE
1	330613	TRASERO HORNILLO 800
1	332748	GUIA CONTACTORES 800
1	350565	FRONTAL INFERIOR 800
2	362476	SOPORTE VALV.MINISIT-CONTACTOR
2	490294	SOPORTE REGLETA MOTOR
1	300939C	CONJ. FRONT.PL.SNACK 800 EL.
1	330422C	CONJ. PETO SNK CORTO 800
1	330608M	CONJ.LAT.SUPERIOR DCH.600
1	330609M	CONJ.LAT.SUPERIOR IZQ.600
2	348173PM	CONJUNTO MANDO ELECTRICO
2	361633C	CONJUNTO PROTECTOR BULBO ELEC.
1	362149C	CONJUNTO CUBETA / CAJON FT
1	362406P	PLANCHA CR LISA 795X540
2	C5120219	PILOTO REDONDO ROJO D.5.5
2	C5123388	CONACTOR
2	C5421619	RESISTENCIA 4000 W FT600/750
2	C5520049	REGLETA MOTOR
1	C5520799	BORNE PHOENIX AZUL UK-10N
1	C5520800	BORNE PHOENIX VERDE-AMA.UK-10N
3	C5520801	BORNE PHOENIX GRIS UK-10N

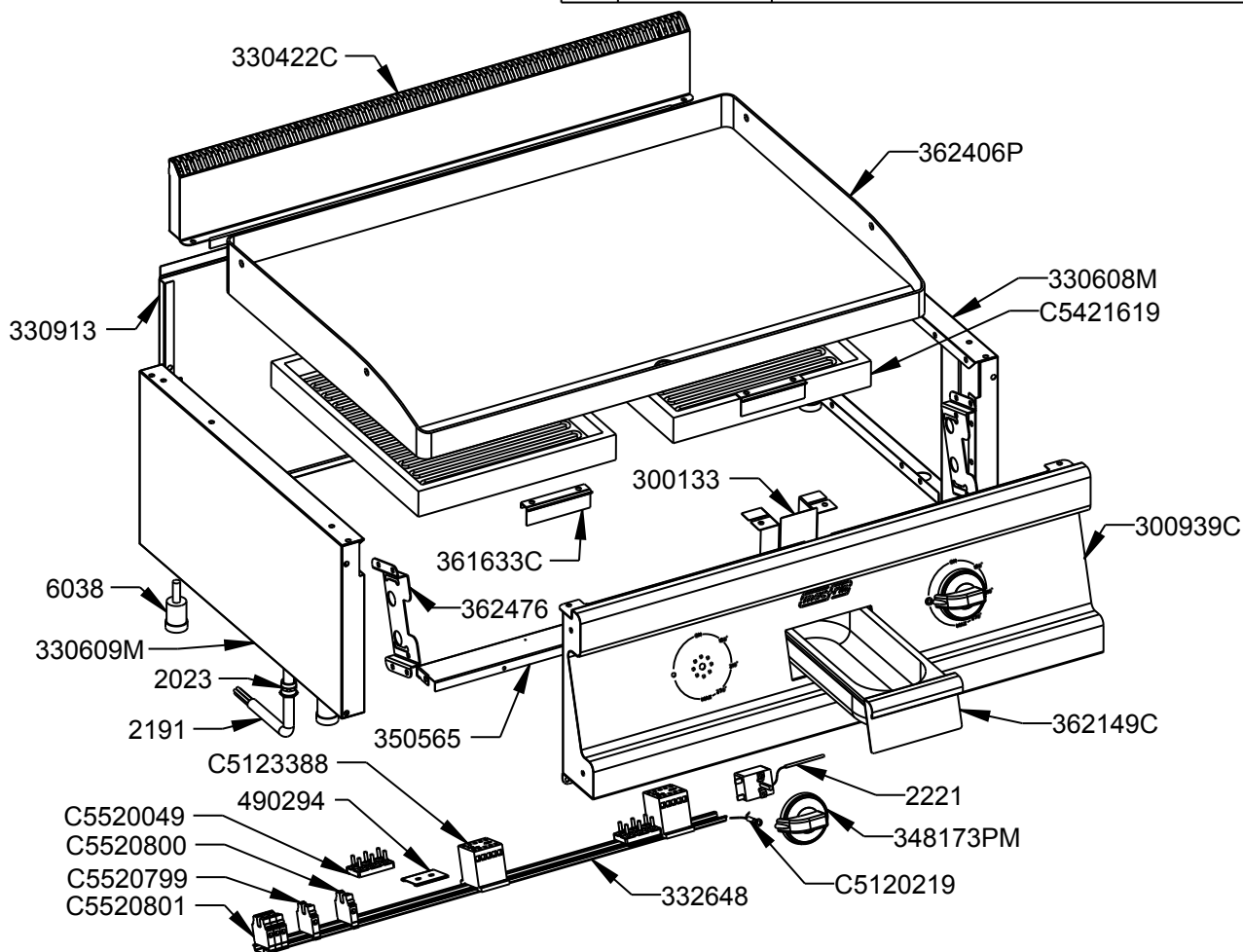

FAMILIA: COCINAS 2008

FECHA: 01/08/11

MODELO: 3009 - SP8CE - SFCME

PESO(Kg): 71.836

DENOMINACION:
PLANCHA SNACK ELEC. 800

ESCALA:
1/10

MATERIAL:
INOX

CODIGO:
3009



Applus®
LGA1
Organismo
Notificado
0370

AENOR
Organismo
Notificado
0099



TOLERANCIAS GENERALES: ± 0.5 mm

QT	COD	DESCRIPCION	FAB.	MATERIAL	DATA	PESO
1	300133	RAMPA CAÍDA ACEITE	SÍ	INOFER 0.8	18/07/08	0.118
1	300178	TAPETA LAT.DCH.FR.CORTO 600	SÍ	INOFER 1.2	09/10/07	0.154
1	300179	TAPETA LAT.IZQ.FR.CORTO 600	SÍ	INOX 1.2	26/06/07	0.154
1	300939	FR. MANDOS PL.SNACK 800 ELECT.	SÍ	INOX 1.2	20/10/09	3.569
1	301578	TAPETA DCH.PETO CORTO SNK	SÍ	INOFER 1.2	09/10/07	0.072
1	301579	TAPETA IZQ.PETO CORTO SNK	SÍ	INOFER 1.2	09/10/07	0.072
1	330422	PETO SOBRE SNACK 800 CORTO	SÍ	INOX 1.2	10/12/08	1.206
1	330608	LATERAL SUPERIOR 600 DCHO	SÍ	INOFER 0.8	29/10/08	1.456
1	330609	LATERAL SUPERIOR 600 IZQ	SÍ	INOFER 0.8	29/10/08	1.456
1	330613	TRASERO HORNILLO 800	SÍ	INOFER 0.8	11/12/08	1.923
3	330675	REFUERZO PATA	SÍ	GALVA 1.5	11/12/08	0.429
1	332748	GUIA CONTACTORES 800	SÍ	GALVA 0.8	30/10/08	0.209
1	350565	FRONTAL INFERIOR 800	SÍ	INOFER 0.8	15/06/10	0.394
2	361633	PROTECTOR BULBO ELEC.	SÍ	INOX 0,8	11/01/11	0.015
1	362148	GUIA CAJON FT(GN 2/8-65)	SÍ	INOFER 0.8	24/10/08	0.280
1	362149	TIRADOR CAJON FT (GN2/8-65)	SÍ	INOX 1.2	19/11/07	0.162
2	362476	SOPORTE VALV.MINISIT-CONTACTOR	SÍ	GALVA 1.5	24/09/08	0.122
2	490294	SOPORTE REGLETA MOTOR	SÍ	GALVA 0.8	07/09/09	0.018
1	3306751	REFUERZO PATA C/ENCAJE BATERIA	SÍ	GALVA 1.5	09/01/09	0.361
2	3616331	SOPORTE PROTECTOR BULBO ELEC.	SÍ	INOFER 0.8	11/01/11	0.031
1	3621491	SOPORTE TIRADOR CAJON FT	SÍ	INOFER 1.2	27/06/08	0.058
1	300939C	CONJ. FRONT.PL.SNACK 800 EL.	SÍ	INOX	20/10/09	4.214
1	330422C	CONJ. PETO SNK CORTO 800	SÍ	INOX	10/12/08	1.367
1	330608M	CONJ.LAT.SUPERIOR DCH.600	SÍ	INOX	17/01/11	2.330
1	330609M	CONJ.LAT.SUPERIOR IZQ.600	SÍ	INOX	17/01/11	2.261
2	361633C	CONJUNTO PROTECTOR BULBO ELEC	SÍ	INOX	11/01/11	0.046
1	362149C	CONJUNTO CUBETA / CAJON FT	SÍ	INOX	27/06/08	0.775
2	TESTA140	ANGULO TESTATINA 140	SÍ	INOX 0.6	29/08/07	0.016
6	TESTA35	ANGULO TESTATINA 35	SÍ	INOX 0.6	29/08/07	0.004
2	TESTA70	ANGULO TESTATINA 70	SÍ	INOX 0.6	29/08/07	0.008
4	1014	REMACHE ROSCADO M-10	NO	ZN	17/12/09	0.008
1	2023	PRENSAESTOPA PG-16 INOX	NO	INOX	14/04/09	0.010
2	2191	CABLE MANGUERA 5X4 (m.l.)	NO	CU	02/08/11	0.500
2	2221	TERMOSTATO 320°	NO	CU	15/04/09	0.078
4	6038	PATA REGULABLE AP.SNACK	NO	BAQUELITA	01/12/93	0.068
2	340172P	ENVELLECEDOR MANDO GAS/ELECT.	NO	ABS	10/12/07	0.012
2	348173P	MANDO ELECTRICO	NO	BAQ	10/12/07	0.096
2	348173PM	CONJUNTO MANDO ELECTRICO	NO	BAQ+ABS	10/12/07	0.108
1	362406P	PLANCHA CR LISA 795X540	NO	CR 15mm	13/01/09	52.465
2	C5120219	PILOTO REDONDO ROJO D.5.5	NO	CU	14/04/09	0.002
2	C5123388	CONACTOR	NO	PLAS.	28/08/09	0.105
2	C5421619	RESISTENCIA 4000 W FT600/750	NO	GALVA	05/05/05	2.159
2	C5520049	REGLETA MOTOR	NO	CERAM.	28/08/09	0.076
1	C5520799	BORNE PHOENIX AZUL UK-10N	NO	PLAS.	10/01/11	0.017
1	C5520800	BORNE PHOENIX VERDE-AMA.UK-10N	NO	PLAS.	10/01/11	0.017
3	C5520801	BORNE PHOENIX GRIS UK-10N	NO	PLAS.	10/01/11	0.017
1	C6440489	CUBETA GN 2/8-65	NO	INOX	19/11/07	0.555



FAMILIA: COCINAS 2008

FECHA: 01/08/11

MODELO: 3009 - SP8CE - SFCME

PESO(Kg): 71.836

DENOMINACION:
PLANCHA SNACK ELEC. 800

ESCALA:
1/10

MATERIAL:
INOX

CODIGO:
3009