



Applus®
LGA1
Organismo
Notificado
0370

AENOR
Organismo
Notificado
0099

FUNDADA EN 1878
MAS BAGA
GRANDES COCINAS

EURAST

mag-fin

TOLERANCIAS GENERALES: ± 0.5 mm

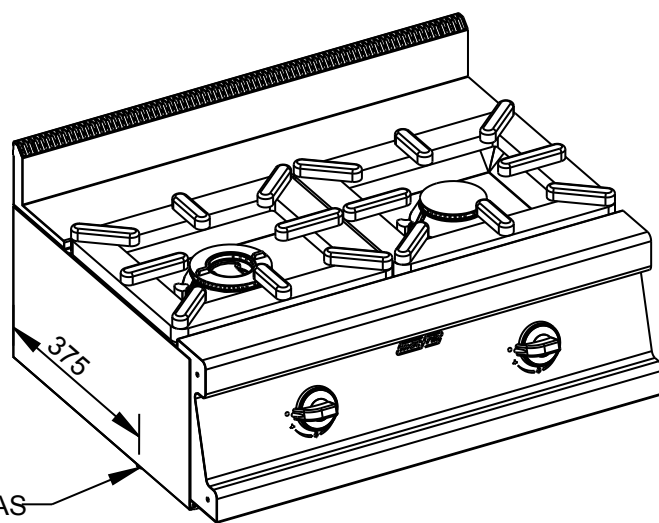
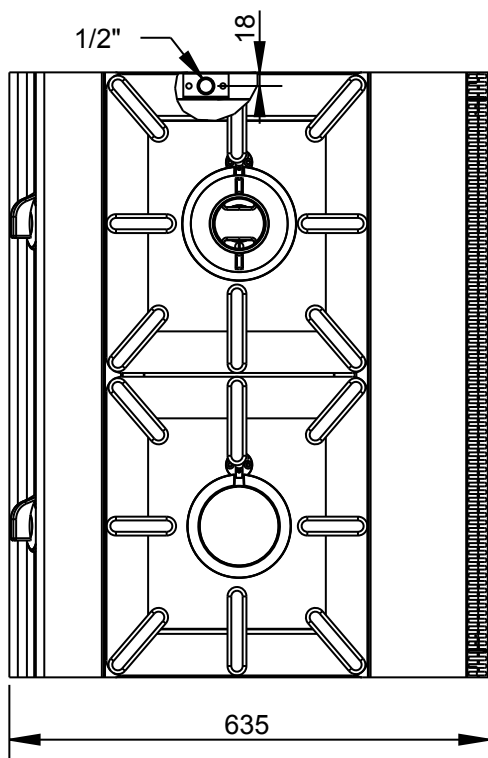
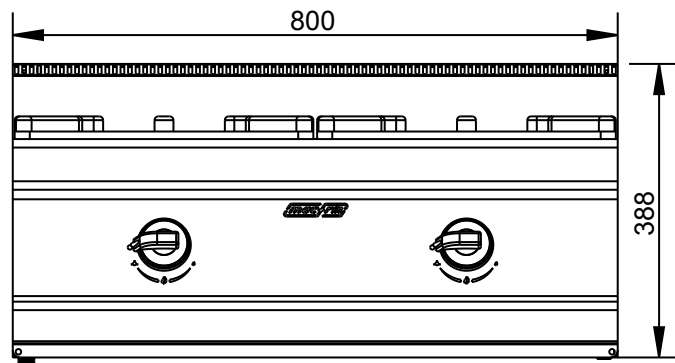
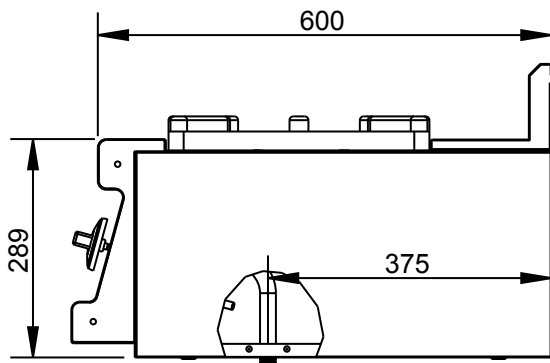

ENTRADA GAS
PARA CONECTAR A HORNO

POTENCIA: 12,7 KW



FAMILIA: COCINAS 2008

FECHA: 03/08/11

MODELO: 3303

PESO(Kg): 29.945

DENOMINACION:
ENCIMERA 2F 600 S.P.

ESCALA:
1/10

MATERIAL:
INOX

CODIGO:
330301M



Applus®
LGA1
Organismo
Notificado
0370

AENOR
Organismo
Notificado
0099

FUNDADA EN 1878
MAS BAGA
GRANDES COCINAS

EURAST

mag-fin

TOLERANCIAS GENERALES: ± 0.5 mm

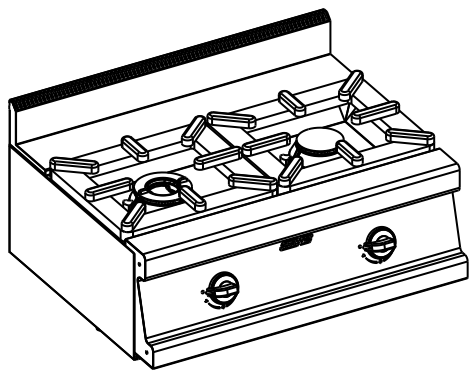

QT	COD	DESCRIPCION
2	3144	PARRILLA SIMPLE
1	330301	SOBRE 2F. 800X600
1	330394	SOPORTE IZQ. BATERÍA
1	330613	TRASERO HORNILLO 800
1	350565	FRONTAL INFERIOR 800
1	330322C	CONJ.PETO SNK LARGO 800
1	330339C	CONJUNTO FRONTAL 2F SNK 800
1	330608M	CONJ.LAT.SUPERIOR DCH.600
1	330609M	CONJ.LAT.SUPERIOR IZQ.600
1	330685PC	BATERIA COMPLETA COCINA 2F. 800
2	340173PM	CONJUNTO MANDO A GAS
1	340187M	CONJUNTO QUEMADOR 9 KW (E)
1	350187M	CONJUNTO QUEMADOR 6.5 KW (D)
2	C5811019	TERMOPAR M8 C/ROSCADA L.320
2	C5811429M	GRIFO COCINA 21-S COMPLETO
2	C5815249M	CONJUNTO PILOTO PAELLERO
2	T06060	TUBO AL D.6 L.600
2	T10045	TUBO AL D.10 L.450

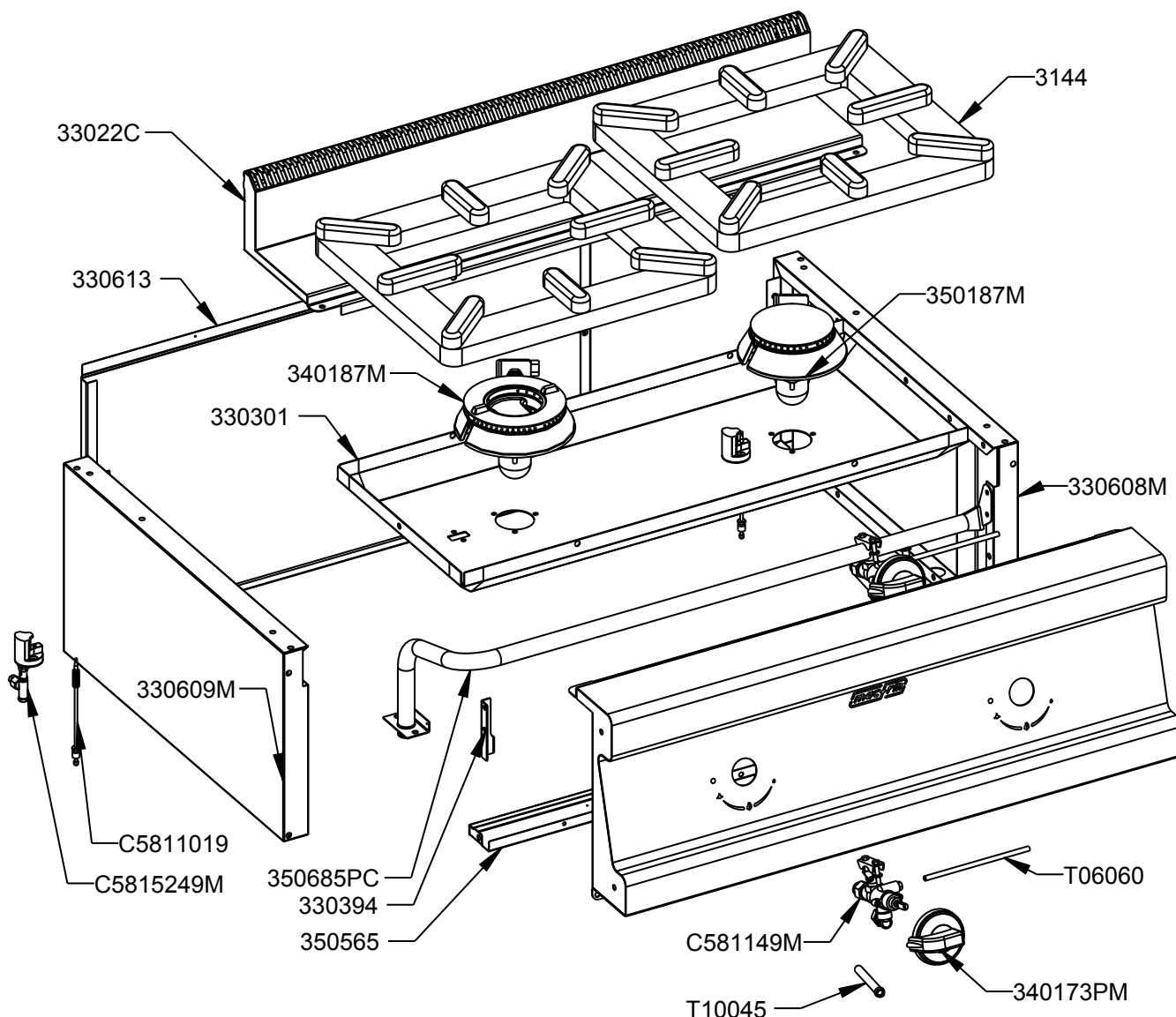

FAMILIA: COCINAS 2008

FECHA: 03/08/11

MODELO: 3303

PESO(Kg): 29.945

DENOMINACION:
ENCIMERA 2F 600 S.P.

ESCALA:
1/8

MATERIAL:
INOX

CODIGO:
330301M



Applus®
LGAI
Organismo
Notificado
0370

AENOR
Organismo
Notificado
0099



TOLERANCIAS GENERALES: ± 0.5 mm

QT	COD	DESCRIPCION	FAB.	MATERIAL	DATA	PESO
1	330194	PLETINA LATERAL BATERÍA	SÍ	FE 1.5	03/11/08	0.012
1	330294	PLETINA BASE BATERÍA	SÍ	FE 1.5	03/11/08	0.021
1	330301	SOBRE 2F. 800X600	SÍ	INOX 0.8	19/01/10	2.694
1	330322	PETO SOBRE SNACK 800 LARGO	SÍ	INOX 1.2	11/12/08	2.190
1	330339	FRONTAL MANDOS 2F SNACK	SÍ	INOX 1.2	21/10/09	4.139
1	330394	SOPORTE IZQ. BATERÍA	SÍ	GALVA 1.5	02/12/08	0.036
1	330608	LATERAL SUPERIOR 600 DCHO	SÍ	INOX 0.8	29/10/08	1.456
1	330609	LATERAL SUPERIOR 600 IZQ	SÍ	INOX 0.8	29/10/08	1.456
1	330613	TRASERO HORNILLO 800	SÍ	INOX 0.8	11/12/08	1.923
3	330675	REFUERZO PATA	SÍ	GALVA 1.5	11/12/08	0.429
1	330978	TAPA DCHA. PETO LARGO SNK	SÍ	INOX 1.2	09/10/07	0.101
1	330979	TAPA IZQ. PETO LARGO SNK	SÍ	INOX 1.2	11/12/08	0.101
1	350178	TAPETA LATERAL DERECHA FRONTAL	SÍ	INOX 1.2	26/06/07	0.109
1	350179	TAPETA LATERAL IZQUIEDA FRONTAL	SÍ	INOX 1.2	26/06/07	0.109
1	350565	FRONTAL INFERIOR 800	SÍ	INOX 0.8	15/06/10	0.394
1	3306751	REFUERZO PATA C/ENCAJE BATERIA	SÍ	GALVA 1.5	09/01/09	0.361
1	330322C	CONJ.PETO SNK LARGO 800	SÍ	INOX	11/12/08	2.442
1	330339C	CONJUNTO FRONTAL 2F SNK 800	SÍ	INOX	21/10/09	4.431
1	330608M	CONJ.LAT.SUPERIOR DCH.600	SÍ	INOX	17/01/11	2.330
1	330609M	CONJ.LAT.SUPERIOR IZQ.600	SÍ	INOX	17/01/11	2.261
4	TESTA140	ANGULO TESTATINA 140	SÍ	INOX 0.6	29/08/07	0.016
6	TESTA35	ANGULO TESTATINA 35	SÍ	INOX 0.6	29/08/07	0.004
4	TESTA70	ANGULO TESTATINA 70	SÍ	INOX 0.6	29/08/07	0.008
4	1014	REMACHE ROSCADO M-10	NO	ZN	17/12/09	0.008
6	1050	TORNILLO ALLEN M5X12 DIN912	NO	INOX	22/05/09	0.004
6	1094	TORNILLO M-5X20 TLR INOX	NO	INOX	01/01/01	0.004
2	3144	PARRILLA SIMPLE	NO	FUND.GRIS	14/06/00	2.699
2	3781	TUERCA M16X1.5 D.10	NO	LATON	05/09/08	0.015
2	3782	BICONO D.10 LATON	NO	LATON	01/01/09	0.001
2	3810	RACORD LATON 90° M-16X1.5	NO	LATON	01/01/01	0.020
1	330685P	BATERIA 2F 800	NO	FE 1/2"	20/04/11	0.739
1	330685PC	BATERIA COMPLETA COCINA 2F. 800	NO	FE 1/2" ZN	20/04/11	0.785
2	340172P	ENVELLEDOR MANDO GAS/ELECT.	NO	ABS	10/12/07	0.012
2	340173P	MANDO COCINA GAS 2008	NO	BAQUELITA	10/12/07	0.064
2	340173PM	CONJUNTO MANDO A GAS	NO	BAQUELITA	10/12/07	0.076
1	340187M	CONJUNTO QUEMADOR 9 KW (E)	NO	FUND	19/01/11	3.093
1	350187M	CONJUNTO QUEMADOR 6.5 KW (D)	NO	FUND	19/01/11	2.755
2	C5811019	TERMOPAR M8 C/ROSCADA L.320	NO	CU	09/02/09	0.015
2	C5811429	GRIFO VALVULA COCINA 21S D.1/2"	NO	LATON	01/01/09	0.354
2	C5811429M	GRIFO COCINA 21-S COMPLETO	NO	LATON	01/01/09	0.396
1	C5815039	CORONA DIFUSOR DOBLE E 9 KW	NO	FUND	30/09/08	0.699
1	C5815049	CUERPO QUEMADOR (E) 9KW.	NO	FUND	30/09/08	1.261
1	C5815059	CODO ESTANCO QUEMADOR E	NO	FUND	30/09/08	0.580
1	C5815069	VENTURI COMPLETO ALUM.	NO	AL	30/09/08	0.357



FAMILIA: COCINAS 2008

FECHA: 03/08/11

MODELO: 3303

PESO(Kg): 29.945

DENOMINACION:
ENCIMERA 2F 600 S.P.

ESCALA:
1/10

MATERIAL:
INOX

CODIGO:
330301M



Applus®
LGA1
Organismo
Notificado
0370

AENOR
Organismo
Notificado
0099



TOLERANCIAS GENERALES: ± 0.5 mm

2	C5815089	GUARNICION JUNTA	NO	KLINGERIT	30/09/08	0.002
2	C5815099	VENTURI PILOTO	NO	LATON	30/09/08	0.006
1	C5815109	CORONA DIFUSOR (D) 6.5 KW.	NO	FUND	30/09/08	0.442
1	C5815119	CUERPO QUEMADOR D 6.5 KW	NO	FUND	30/09/08	1.075
1	C5815129	CODO ESTANCO QUEMADOR (D)	NO	FUND	30/09/08	0.716
1	C5815139	VENTURI (D) COMPLETO	NO	AL	30/09/08	0.326
2	C5815149	SOPORTE QUEMADOR HORIZONTAL	NO	INOX	30/09/08	0.099
2	C5815159	PORTAINYECTOR COMPLETO	NO	LATON	01/01/09	0.058
2	C5815169	CUERPO QUEMADOR PILOTO	NO	LATON	30/09/08	0.020
2	C5815189	REGULADOR DE AIRE PILOTO	NO	FE	30/09/08	0.001
1	C5815199	INYECTOR GN (E) DIAM. 2.20	NO	LATON	30/09/08	0.006
1	C5815209	INYECTOR GN (D) DIAM.1.50	NO	LATON	30/09/08	0.006
1	C5815219	INYECTOR GLP (E) DIAM.1.45	NO	LATON	30/09/08	0.006
1	C5815229	INYECTOR GLP (C) DIAM.1.05	NO	LATON	30/09/08	0.006
2	C5815249	PILOTO HERMETICO PAELLERO	NO	LATON	05/02/10	0.153
2	C5815249M	CONJUNTO PILOTO PAELLERO	NO	LATON	27/01/10	0.187
2	C5815279	JUNTA PILOTO HERMETICO	NO	GOMA	01/06/11	0.001
4	C5815359	TUERCA+BICONO D.6 M10X1	NO	LATON	01/01/09	0.006
1	C5816309	TOMA DE PRESIÓN PARA BATERIA	NO	LATON	31/03/11	0.013
2	T06060	TUBO AL D.6 L.600	NO	AL 99.7%	13/05/09	0.015
2	T10045	TUBO AL D.10 L.450	NO	AL 99.7%	13/05/09	0.011



FAMILIA: COCINAS 2008

FECHA: 03/08/11

MODELO: 3303

PESO(Kg): 29.945

DENOMINACION:
ENCIMERA 2F 600 S.P.

ESCALA:
1/10

MATERIAL:
INOX

CODIGO:
330301M



Applus®
LGA1
Organismo
Notificado
0370

AENOR
Organismo
Notificado
0099

FUNDADA EN 1878
MAS BAGA
GRANDES COCINAS

EURAST

mac-fin

TOLERANCIAS GENERALES: ± 0.5 mm

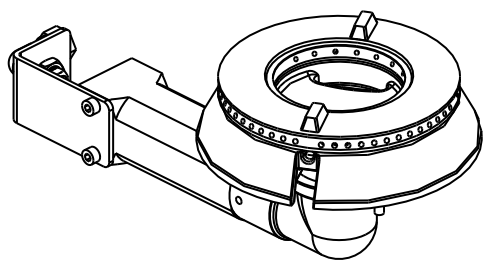

QT	COD	DESCRIPCION
3	1050	TORNILLO ALLEN M5X12 DIN912
3	1094	TORNILLO M-5X20 TLR INOX
1	C5815039	CORONA DIFUSOR DOBLE E 9 KW
1	C5815049	CUERPO QUEMADOR (E) 9KW.
1	C5815059	CODO ESTANCO QUEMADOR E
1	C5815069	VENTURI COMPLETO ALUM.
1	C5815089	GUARNICION JUNTA
1	C5815149	SOPORTE QUEMADOR HORIZONTAL
1	C5815159	PORTAINYECTOR COMPLETO
1	C5815199	INYECTOR GN (E) DIAM. 2.20
1	C5815219	INYECTOR GLP (E) DIAM.1.45

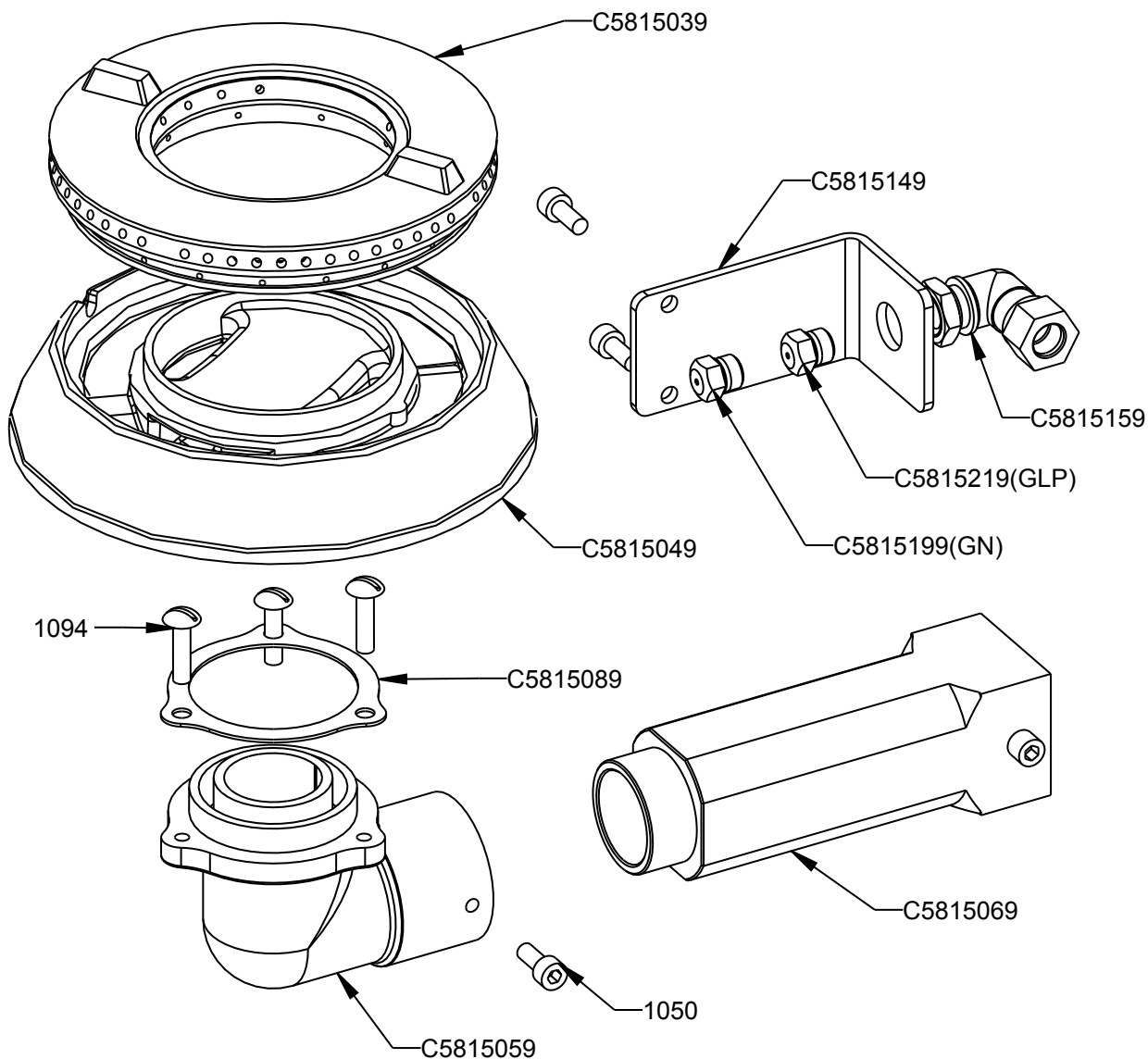

FAMILIA: COCINAS 2008

FECHA: 19/01/11

MODELO: 3401

PESO(Kg): 3.093

DENOMINACION:
CONJUNTO QUEMADOR 9 KW (E)

ESCALA:
1/2

MATERIAL:
FUND

CODIGO:
340187M



Applus®
LGA1
Organismo
Notificado
0370

AENOR
Organismo
Notificado
0099

FUNDADA EN 1878
MAS BAGA
GRANDES COCINAS

EURAST

mag-fin

TOLERANCIAS GENERALES: ± 0.5 mm

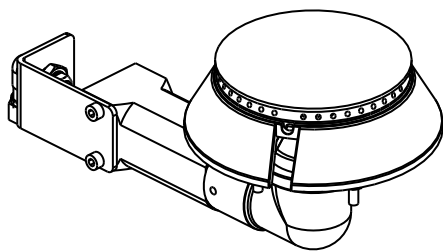

QT	COD	DESCRIPCION
3	1050	TORNILLO ALLEN M5X12 DIN912
3	1094	TORNILLO M-5X20 TLR INOX
1	C5815089	GUARNICION JUNTA
1	C5815109	CORONA DIFUSOR (D) 6.5 KW.
1	C5815119	CUERPO QUEMADOR D 6.5 KW
1	C5815129	CODO ESTANCO QUEMADOR (D)
1	C5815139	VENTURI (D) COMPLETO
1	C5815149	SOPORTE QUEMADOR HORIZONTAL
1	C5815159	PORTAINYECTOR COMPLETO
1	C5815209	INYECTOR GN (D) DIAM.1.50
1	C5815229	INYECTOR GLP (C) DIAM.1.05

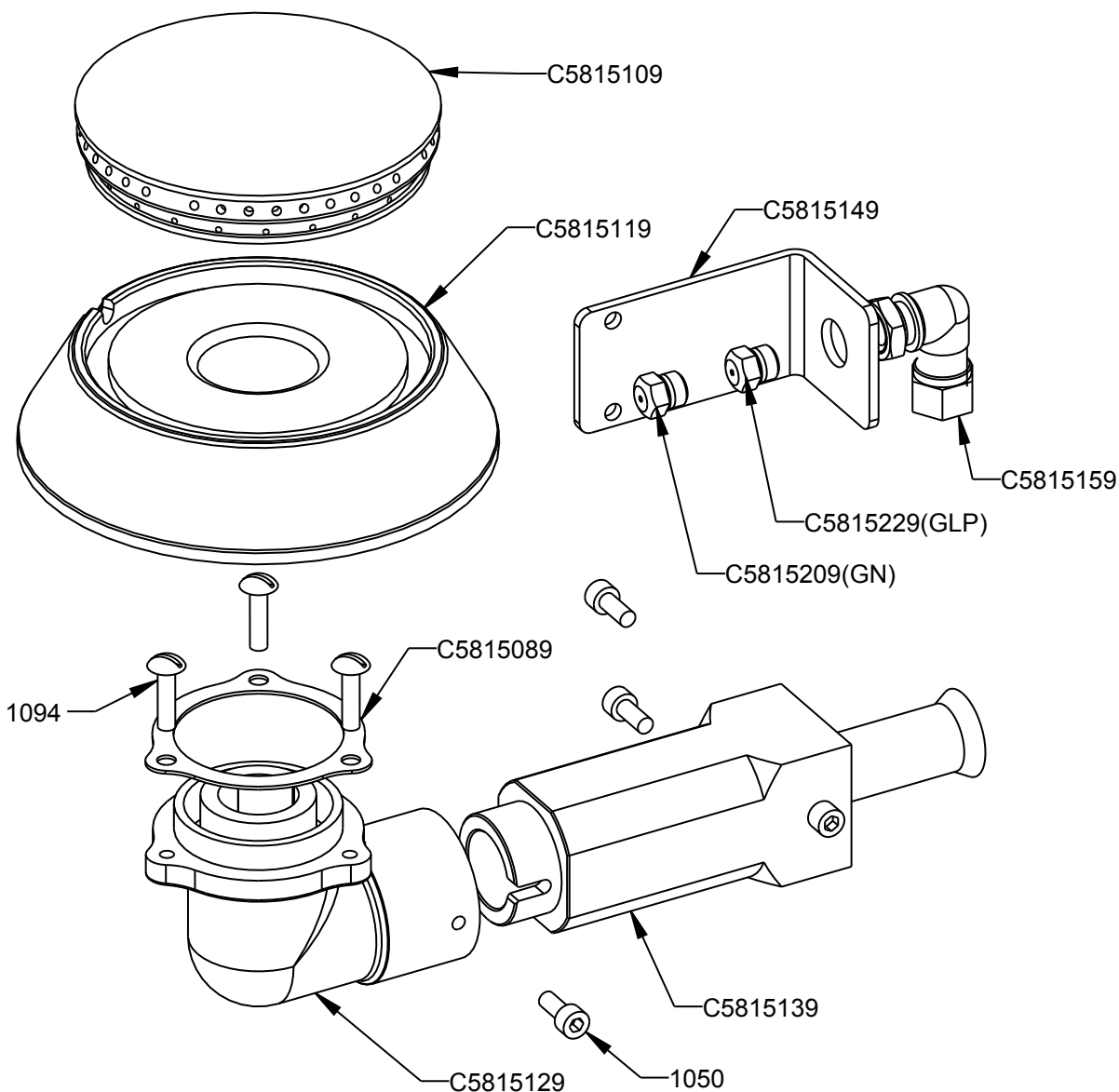

FAMILIA: COCINAS 2008

FECHA: 19/01/11

MODELO: 3501

PESO(Kg): 2.755

DENOMINACION:
CONJUNTO QUEMADOR 6.5 KW (D)

ESCALA:
1/2

MATERIAL:
FUND

CODIGO:
350187M



Applus®
LGA1
Organismo
Notificado
0370

AENOR
Organismo
Notificado
0099

FUNDADA EN 1878
MAS BAGA
GRANDES COCINAS

EURAST

mac-fin

TOLERANCIAS GENERALES: ± 0.5 mm

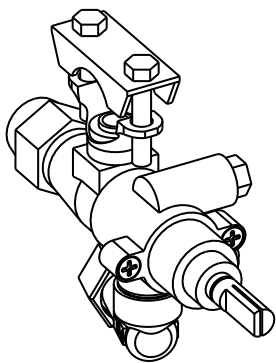

QT	COD	DESCRIPCION
1	3781	TUERCA M16X1.5 D.10
1	3782	BICONO D.10 LATON
1	3810	RACORD LATON 90° M-16X1.5
1	C5811429	GRIFO VALVULA COCINA 21S D.1/2"
1	C5815359	TUERCA+BICONO D.6 M10X1

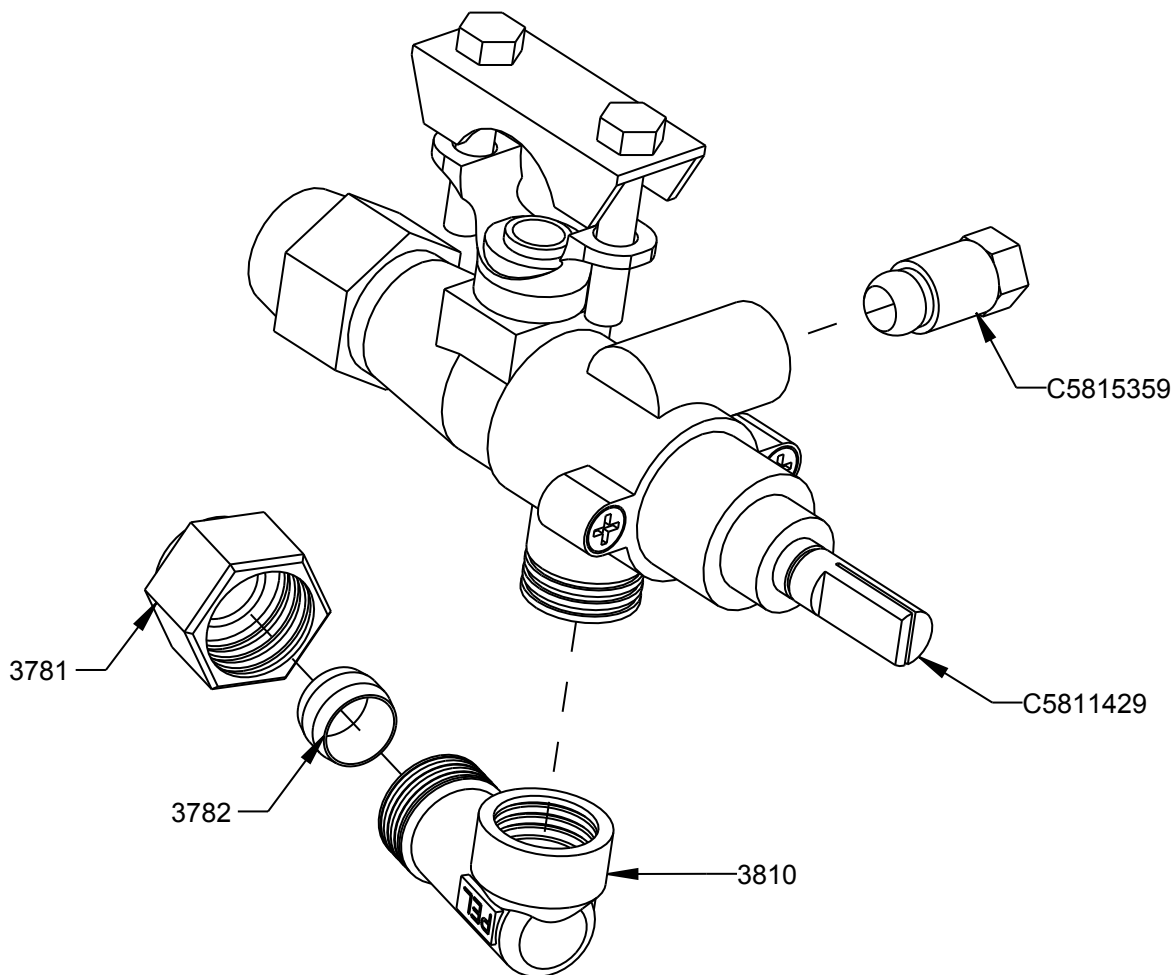

FAMILIA: COCINAS 2008

FECHA: 01/01/09

MODELO: 3401

PESO(Kg): 0.396

DENOMINACION:
GRIFO COCINA 21-S COMPLETO

ESCALA:
1/1

MATERIAL:
LATON

CODIGO:
C5811429



Applus®
 LGAI
 Organismo
 Notificado
0370

AENOR
 Organismo
 Notificado
0099

FUNDADA EN 1878
MAS BAGA
 GRANDES COCINAS

EURAST

mac-fini

TOLERANCIAS GENERALES: ± 0.5 mm

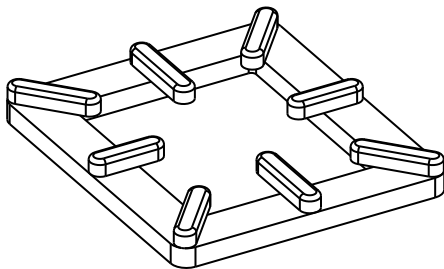
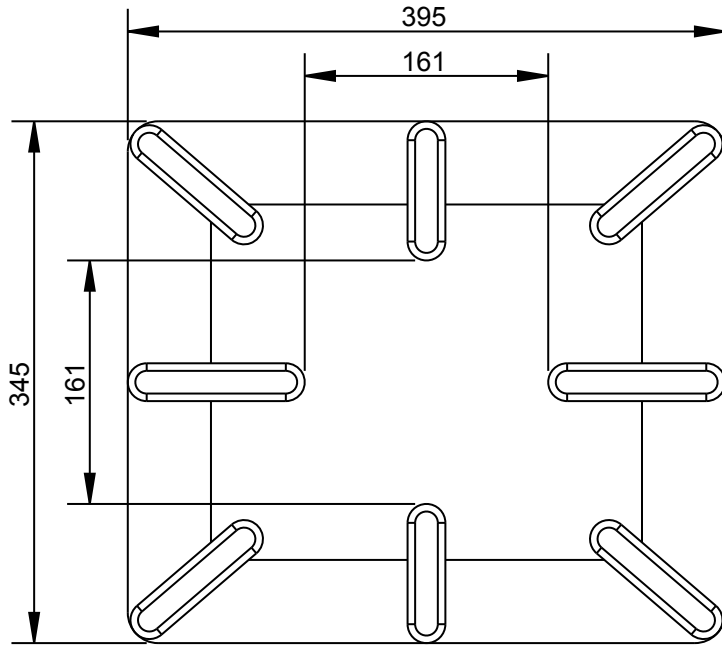
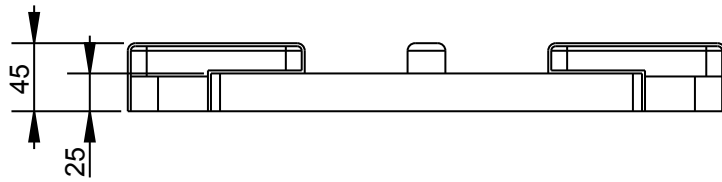

FAMILIA: COCINAS

FECHA: 14/06/00

MODELO: 3401

PESO(Kg): 2.699

DENOMINACION:
 PARRILLA SIMPLE

ESCALA:
 1/5

MATERIAL:
 FUND.GRIS

CODIGO:
 3144