

**Mantenedor de Fritos
Chauffe Frites
Chips Scuttle
Scaldapatate
Conservador de Frituras
Frittenwanne**

GAMA SNACK

Modelos:

MF6-05

Junio 2009 June



Fagor Industrial

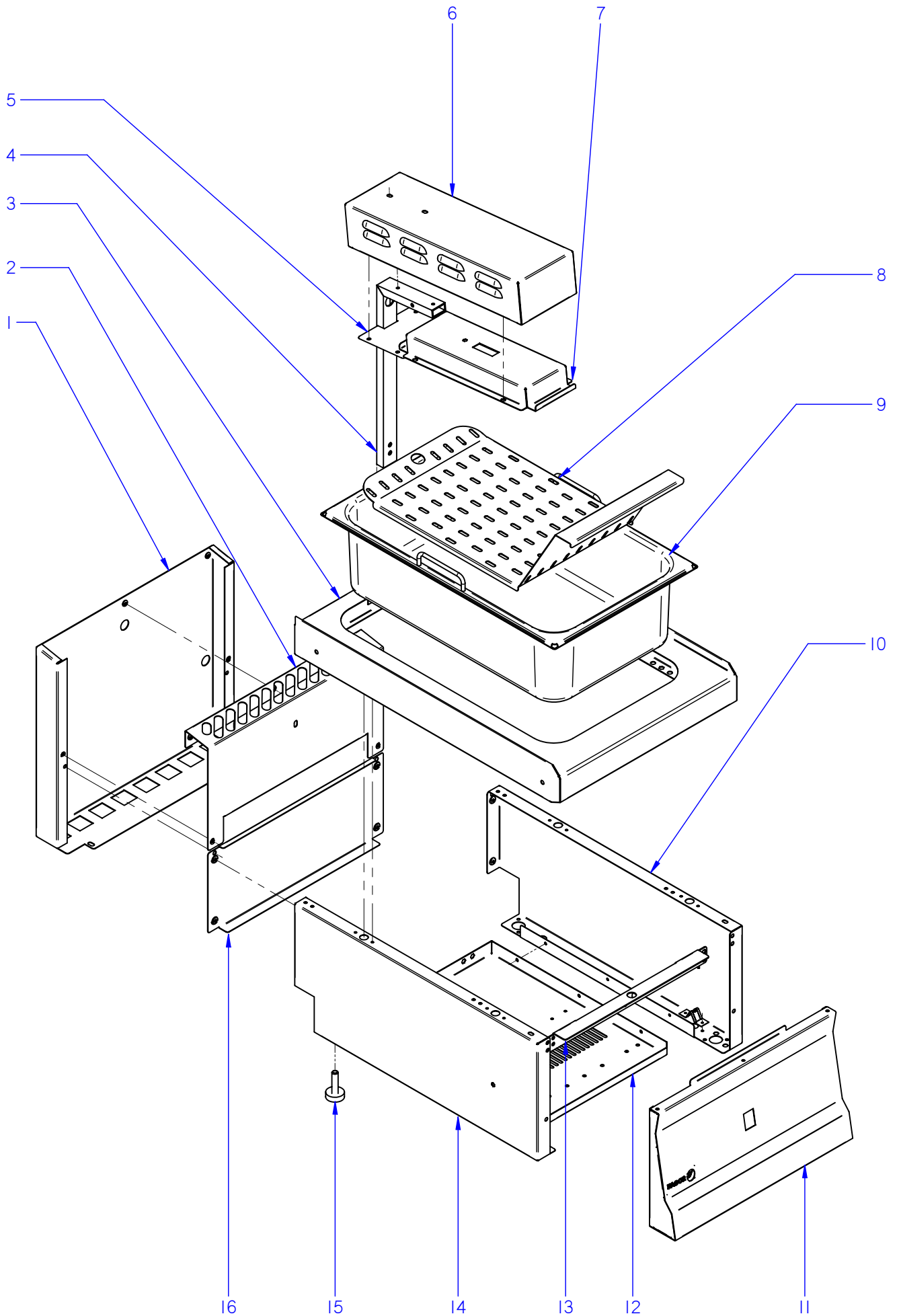

ITEM MARCADO EN COLOR = REPUESTO RECOMENDADO
 COLOURED ITEM = RECOMMENDED SPARE PART

N plano	Firma	Fecha	Aparato	MUEBLE	Lamina	Fagor Industrial S.Coop. FAGOR
C-2399	<i>(Signature)</i>	2009-06	MANTENEDOR DE FRITOS MF6-05		1	Oñate

MOD.		MANTENEDOR DE FRITOS CHIPS SCUTTLE		ZONA	MUEBLE / UNIT				PLANO	C-2399
ITEM	CODIGO	DENOMINACION	TEXTO	MF6-05					NOTAS	
1	J142809000	PROTECCION CHIMENEA POS. 400	PROTECTION CHIMEMEY POS.	1						
	Q419005000	REMACHE 4X8 ALMG3 / ALUMINIO	RIVET 4X8 ALMG3 / ALUMINIUM	2						
2	J272806000	PROTECCION CHIMENEA MF6-05	PROTECT. CHIMENEA MF6-05	1						
	Q012031000	TORNILLO EXAGONAL M5x10 A304	HEXAGONAL BOLT M5x10 A304	4						
	Q302022000	ARANDELA 16x6x1,2 A304	WASHER 16x6x1.2 A304	4						
	Q221342000	REMACHE EXAGONAL M5	HEXAGONAL RIVET M5	3						
3	J275417000	ENCIMERA MF6-05	TOP MF6-05	1						
	Q221342000	REMACHE EXAGONAL M5	HEXAGONAL RIVET M5	4						
	X012612000	PITON CIERRE	LOCK SPIKE	4						
	Q221342000	REMACHE EXAGONAL M5	HEXAGONAL RIVET M5	2						
4	J275418000	POSTE COMPL.CHIPS SCUTTLE	COMPL. COLUMN CHIPS SCUTTLE	1						
5	J272602000	CUBIERTA DE CAJA	COVER OF BOX	1						
	Q152004000	TORNIL. APLASTADO M5X13 A 304	FLAT HEADED SCREW M5x13 A 304	4						
6	J275406000	TAPA PROTECCIÓN	PROTECTION CAP	1						
	Q221342000	REMACHE EXAGONAL M5	HEXAGONAL RIVET M5	4						
7	J272601000	CAJA DE RESISTENCIAS	BOX OF RESISTENCES	1						
	Q221342000	REMACHE EXAGONAL M5	HEXAGONAL RIVET M5	4						
	Q152004000	TORNIL. APLASTADO M5X13 A 304	FLAT HEADED SCREW M5x13 A 304	4						
8	J272805000	PANEL SEPARADOR	PANEL SEPARATOR	1						
9	J275415000	FUENTE 1/1 CON ASA	DISH 1/1 WITH HANDLE	1						
10	J002802000	PANEL LATERAL DERECHO	RIGHT SIDE PANEL	1						
	Q221342000	REMACHE EXAGONAL M5	HEXAGONAL RIVET M5	1						
	Q419007000	REMACHE TUBULAR C/V D3.2X6	TUBULAR RIVET C/V D3.2X6	8						
	X010503000	CIERRE MUELLE	LOCK SPRING	4						
11	J272802000	PORTAMANDOS MF6-05	CONTROL HOLDER MF6-05	1						
	U022836000	ESCUDO FAGOR	FAGOR EMBLEM	1						
	Q221023000	CLIP SUJECIÓN RÁPIDA Ø5	RAPID CONNECT CLIP Ø5	2						
	Q419005000	REMACHE 4x8 ALMG3 / ALUMINIO	RIVET 4X8 ALMG3 / ALUMINIUM	6						
	Q012031000	TORNILLO EXAGONAL M5x10 A304	HEXAGONAL BOLT M5x10 A304	2						
	Q302022000	ARANDELA 16x6x1,2 A304	WASHER 16x6x1.2 A304	2						

MOD.	MANTENEDOR DE FRITOS CHIPS SCUTTLE	ZONA	MUEBLE / UNIT	PLANO	C-2399
------	---------------------------------------	------	---------------	-------	--------

ITEM	CODIGO	DENOMINACION	TEXTO	MF6-05								NOTAS
12	J002604000	BASE INFERIOR 400	LOWER BASE 400	1								
	Q419005000	REMACHE 4X8 ALMG3 / ALUMINIO	RIVET 4X8 ALMG3 / ALUMINIUM	6								
13	J002610000	GUÍA PANEL PORTAMANDOS 400	GUIDE PANEL OF CONTROLS	1								
	Q221342000	REMACHE EXAGONAL M5	HEXAGONAL RIVET M5	4								
	Q012031000	TORNILLO EXAGONAL M5x10 A304	HEXAGONAL BOLT M5x10 A304	4								
14	J002801000	PANEL LATERAL IZQUIERDO	LEFT SIDE PANEL	1								
	Q221342000	REMACHE EXAGONAL M5	HEXAGONAL RIVET M5	1								
	Q419007000	REMACHE TUBULAR C/V D3.2X6	TUBULAR RIVET C/V D3.2X6	8								
	X010503000	CIERRE MUELLE	LOCK SPRING	4								
15	Z200107000	PATA REGULABLE	ADJUSTABLE LEG	4								
16	J002803000	PANEL POSTERIOR 400	REAR PANEL 400	1								
	Q419005000	REMACHE 4x8 ALMG3 / ALUMINIO	RIVET 4X8 ALMG3 / ALUMINIUM	4								

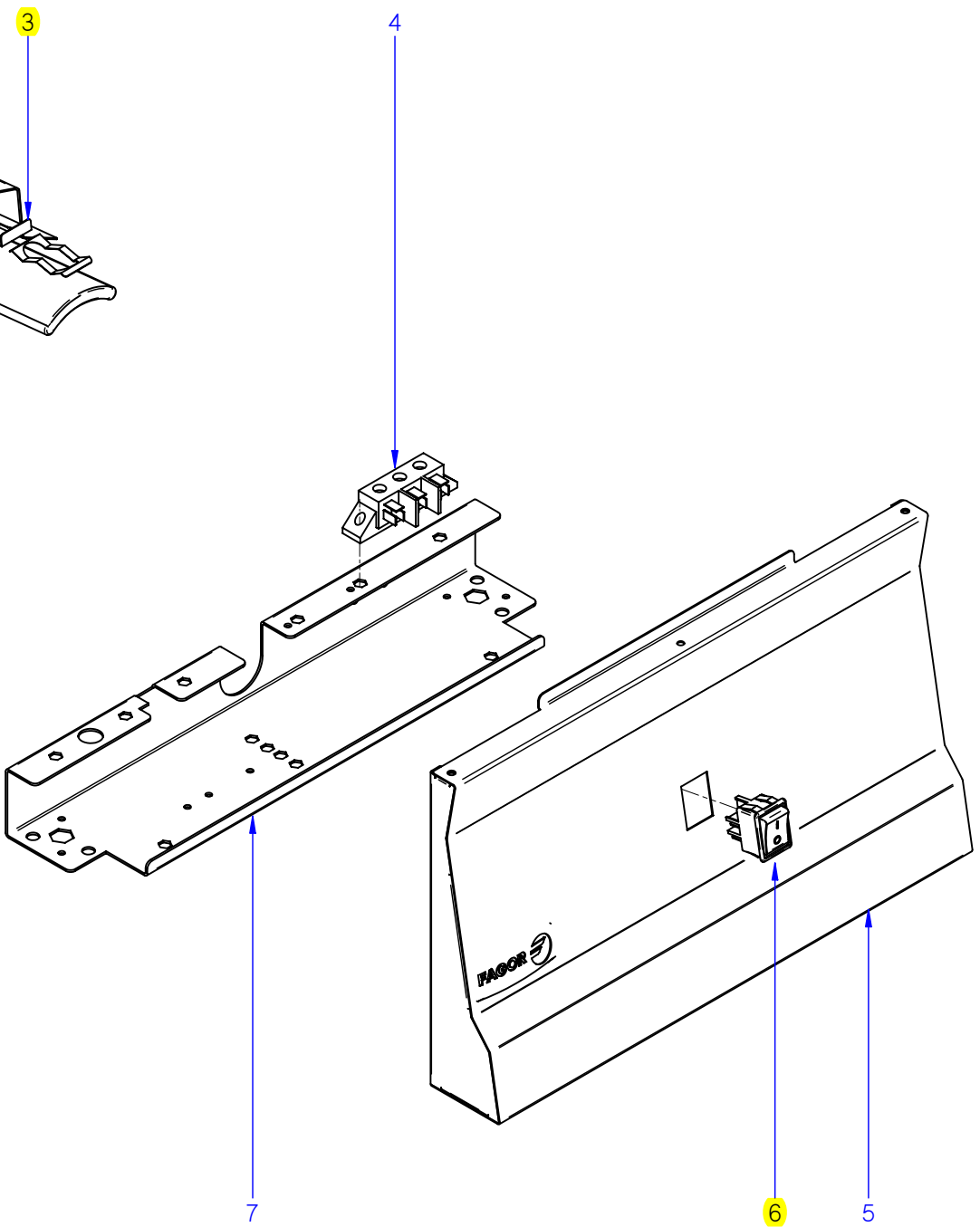
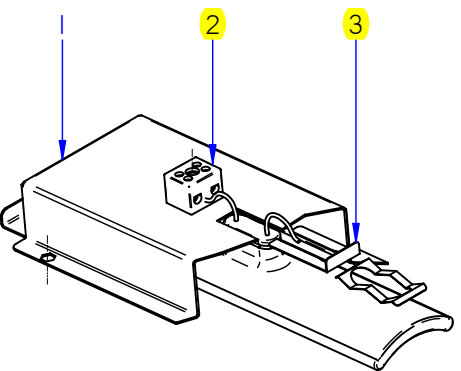

ITEM MARCADO EN COLOR = REPUESTO RECOMENDADO
COLOURED ITEM = RECOMMENDED SPARE PART

N plano	Firma	Fecha	Aparato	Lamina	Fagor Industrial S. Coop.
C-2400		2009-06	MANTENEDOR DE FRITOS MF6-05	2	Onate
CONJUNTO FUNCIONAL					
FAGOR					

MOD.	MANTENEDOR DE FRITOS CHIPS SCUTTLE	ZONA	CONJUNTO FUNCIONAL / FUNCTIONAL UNIT	PLANO	C-2400
-------------	---	-------------	---	--------------	---------------

ITEM	CODIGO	DENOMINACION	TEXTO	MF6-05								NOTAS
1	J272601000	CAJA DE RESISTENCIAS	BOX OF RESISTENCES	1								
	Q221342000	REMACHE EXAGONAL M5	HEXAGONAL RIVET M5	4								
	Q152004000	TORNIL. APLASTADO M5X13 A 304	FLAT HEADED SCREW M5x13 A 304	4								
2	J272101000	REGLETA CERAMICA CP6-05	CERAMIC TERMINAL STRIP	1								
3	J273001000	RESISTENCIA INFRARROJOS	RESISTANCE INFRARED	1								
4	U183046000	REGLETA AUXILIAR	AUXILIARY TERMINAL	1								
	Q152004000	TORNIL. APLASTADO M5X13 A 304	FLAT HEADED SCREW M5x13 A 304	2								
5	J272802000	PORTAMANDOS MF6-05	CONTROL HOLDER MF6-05	1								
6	Z203033000	INTERRUPTOR GENERAL	POWER SWITCH	1								
7	J002602000	FRONTAL SUPERIOR 400	FRONT SUPPORT 400	1								

MOD.		MANTENEDOR DE FRITOS CHIPS SCUTTLE		ZONA	VARIOS / MISCELLANEOUS				PLANO
ITEM	CODIGO	DENOMINACION	TEXTO	MF6-05					NOTAS
	J276501000	FOLLETO DE INSTRUC. MF6-05	INSTRUC. LEAFLET MF6-05	1					
	J273002000	ESQUEMA TEORICO MF6-05	THEOR. DIAGRAM MF6-05	1					PLANO HB-80537
	J273003000	ESQUEMA MONTAJE	ASSEMBLY DIAGRAM	1					PLANO HC-80539
	J273004000	INSTALAC. ELECTRICA CP6-05	ELECTR. INSTALLATION CP6-05	1					

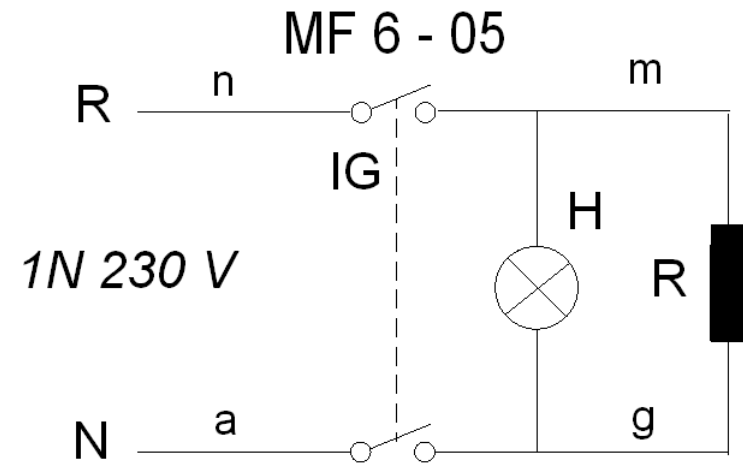

a = azul-blue m = marron - brown g = gris - grey n = negro-black

IG: Interruptor general/Main switch

H: Piloto encendido / Operation light

R: Resistencia/Resistance

J273002000

-	Theoretical diagram: MF		-	-	J273002000	-
Zk./N°	Pieza	Cant.	Materiala/Material	Klas. zk./N° Clas.	Gainazal akabera/Tratamiento	
Zk./N°	Aldaketa/Modificaciones		Nork. proposatua/Propuesta de	Data/Fecha	Perdoi orokorrak Tolerancias generales	
-	-	-	-	-	$\leq 5 \pm 0.2$ $50 - 100 \pm 0.8$ $5 + 25 \pm 0.4$ $> 100 \pm 1$ $25 + 50 \pm 0.6$ $\varnothing \pm 1$	
-	-	-	-	-	Gainazal perdoia Mecanizado superficial	
Marratzua/Dibujado	e.carrascal	2008-11-12	 Fagor Industrial, Koop. Elk., Mugatua		-	
Proiektatua/Proyectado	e.carrascal	2008-11-12				
Egiaztatua/Comprobado	<i>f.alberdi</i>	2008-11-12				
Eskala/Escala	COOKING				Plano Zk./Plano N°	HB-80537
-	Plano hau ezin daiteke erabili, ez berrizatu, gure baimenik gabe.				-	Zk. ord. du
-					-	Zk.gaitik ord.

MF 605

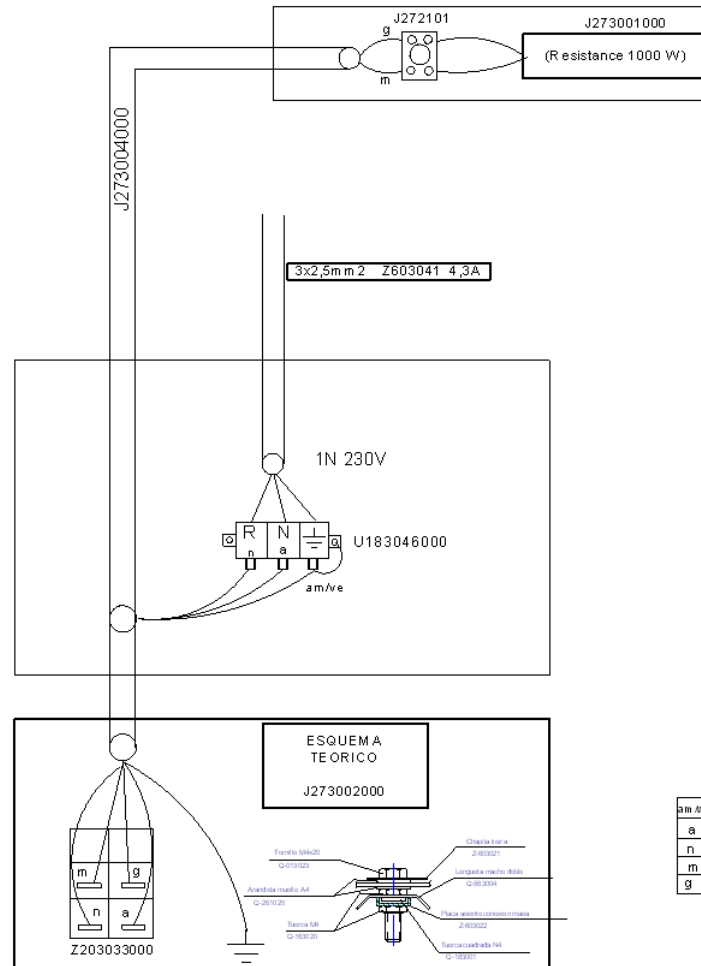

COLORS	
am/te	amarillo/verde yellow/green
a	azul blue
n	negro black
m	marron brown
g	gris grey

- PLANO MONTAJE MF 605		- J273003000			
Zk/Nº	Pieza	Cant.	Materia/Material	Klas. zk/Nº Clas.	Gainazal akabera/Tratamiento
Zk/Nº	Aldaketa/Modificaciones		Nork proposatua/Propuesta de	Data/Fecha	Perdoi orokorrak Tolerancias generales
-	-	-	-	-	< 5 ± 0.2 50 - 100 ± 0.8
-	-	-	-	-	5 + 25 ± 0.4 > 100 ± 1
-	-	-	-	-	25 + 50 ± 0.6 α ± 1°
Marratzua/Dibujado	M.Mailló	2009-05-12	 Fagor Industrial, Koop. Elk., Mugatua		Gainazal perdoia Mecanizado superficial
Proiektatua/Proyectado	M.Mailló	2009-05-12			-
Egiaztatua/Comprobado	i Alberdi	2009-05-12			-
Eskala/Escala	CHIPS SCUTTLE				Plano Zk./Plano N° HB-80539
Plano hau ezin daiteke erabili, ez berrizatu, gure baimenik gabe.					- Zk. ord. du
					- Zk.gaitik ord.