



**Applus®**  
LGAI  
Organismo  
Notificado  
**0370**

**AENOR**  
Organismo  
Notificado  
**0099**



TOLERANCIAS GENERALES: ±0.5 mm

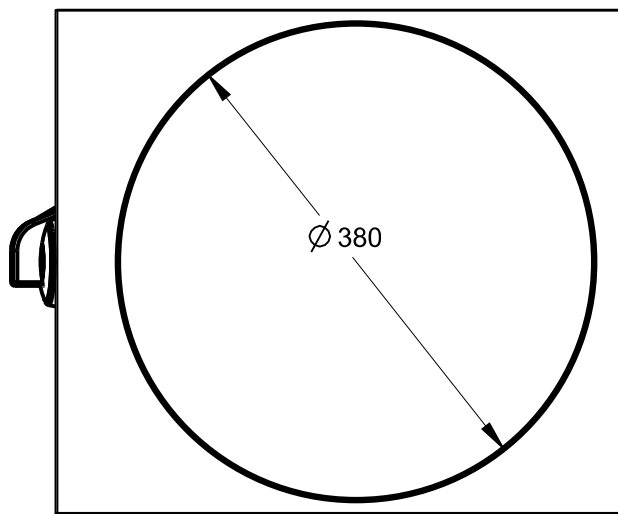
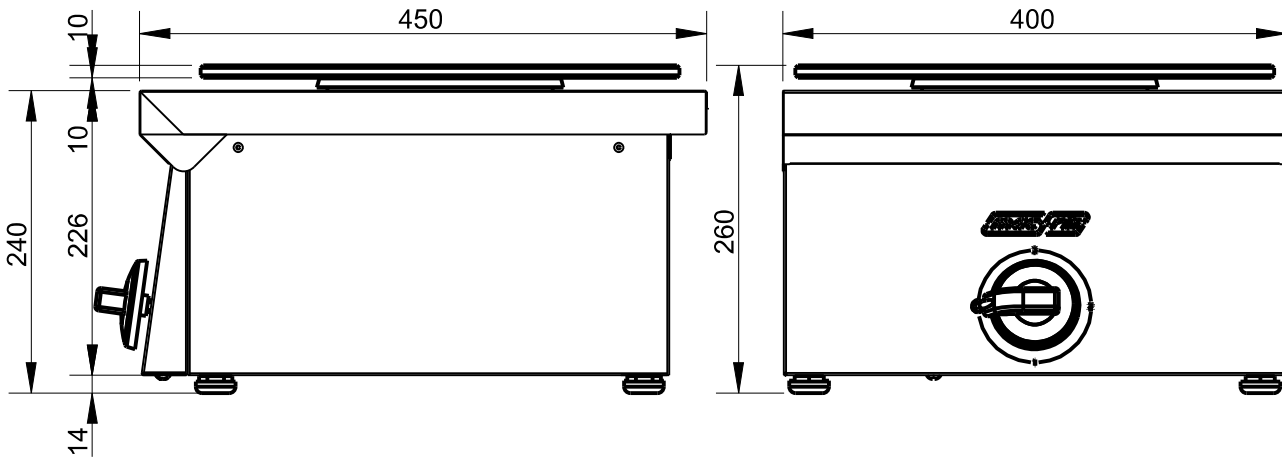

DISCO EXTRAÍBLE  
PARA FACILITAR SU  
LIMPIEZA

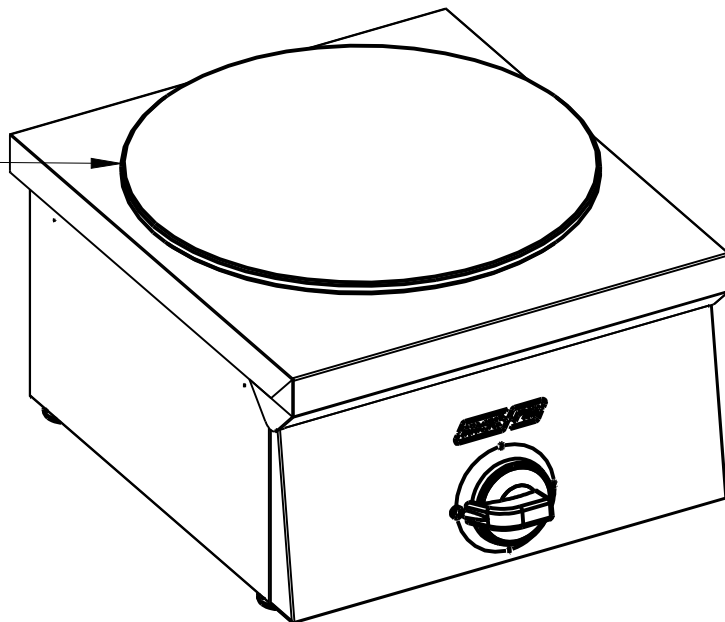

POTENCIA: 2.000W

CONEXIÓN: CABLE 3X2.5 (3m) CON CLAVIJA



FAMILIA: BAR 2009

FECHA: 03/05/10

MODELO: 4418

PESO(Kg): 18.722

DENOMINACION:  
CREPERA 1 PLACA ELEC.

ESCALA:  
1/6

MATERIAL:  
INOX

CODIGO:  
4418



**Applus®**  
LGAI  
Organismo  
Notificado  
**0370**

**AENOR**  
Organismo  
Notificado  
**0099**



TOLERANCIAS GENERALES: ±0.5 mm

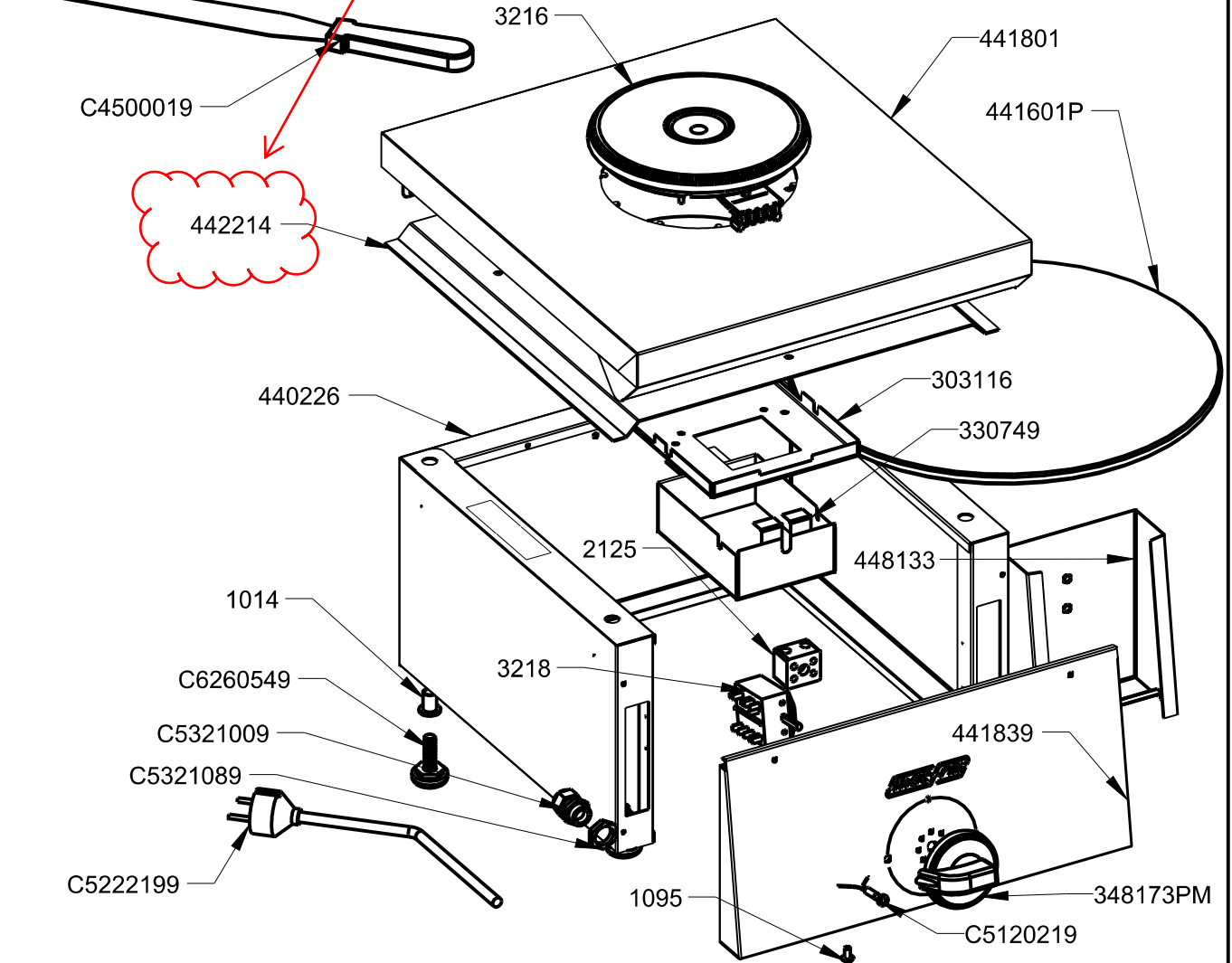
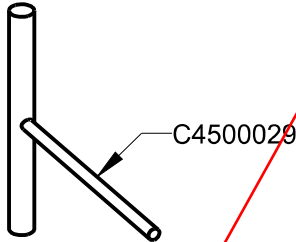
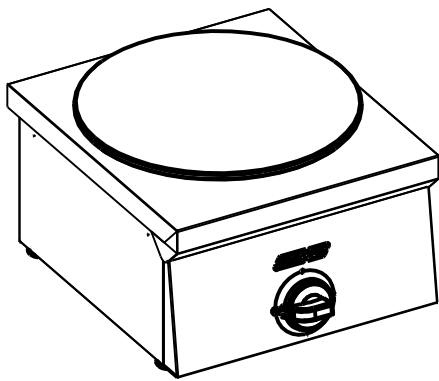

QT	COD	DESCRIPCION
4	1014	REMACHE ROSCADO M-10
1	1095	TORNILLO M-5X10 TLR INOX
1	2125	REGLETA CERÁMICA BP16
1	3216	PLACA ELEC.2000W-220/I
1	3218	CONMUTADOR 49.24215.520
1	303116	REFUERZO PLACA ELECTRICA REDONDA
1	330749	CAJA CONEXIONES PLACAS ELEC.
1	440226	ENVOLVENTE BAR 400
1	441801	SOBRE CREPERA ELEC.400
1	441839	FRONTAL MANDOS CREPERA ELEC.
1	443214	REFUERZO SOBRE BAR 400
1	448133	PROTECTOR CONEXIONES 450
1	348173PM	CONJUNTO MANDO ELECTRICO
1	441601P	PLACA CREPERA D.380 PAVONADA
1	C4500019	ESPATULA CREPERA
1	C4500029	DISPENSADOR CREPERA
1	C5120219	PILOTO REDONDO ROJO D.5.5
1	C5222199	CABLE 3X2.5 C/ENCHUFE
1	C5321009	PRENSAESTOPA PG-11
1	C5321089	TUERCA PG-11
4	C6260549	PATA PA M-10X30 BASE D.30



FAMILIA: BAR 2009

FECHA: 03/05/10

MODELO: 4418

PESO(Kg): 18.722

DENOMINACION:  
CREPERA 1 PLACA ELEC.

ESCALA:  
1/6

MATERIAL:  
INOX

CODIGO:  
4418



**Applus®**  
LGA1  
Organismo  
Notificado  
**0370**

**AENOR**  
Organismo  
Notificado  
**0099**



TOLERANCIAS GENERALES: ±0.5 mm

QT	COD	DESCRIPCION	FAB.	MATERIAL	DATA
1	303116	REFUERZO PLACA ELECTRICA REDONDA	SÍ	GALVA 1.5	29/10/09
1	330749	CAJA CONEXIONES PLACAS ELEC.	SÍ	GALVA 0.8	29/06/09
1	440226	ENVOLVENTE BAR 400	SÍ	INOFER 0.8	04/03/10
1	441801	SOBRE CREPERA ELEC.400	SÍ	INOFER 0.8	21/05/10
1	441839	FRONTAL MANDOS CREPERA ELEC.	SÍ	INOFER 0.8	03/05/10
1	443214	REFUERZO SOBRE BAR 400	SÍ	GALVA 1.5	06/05/10
1	448133	PROTECTOR CONEXIONES 450	SÍ	GALVA 0.8	17/05/11
4	1014	REMACHE ROSCADO M-10	NO	ZN	17/12/09
1	1095	TORNILLO M-5X10 TLR INOX	NO	INOX	01/01/09
1	2125	REGLETA CERÁMICA BP16	NO	CERAM.	29/09/09
1	3216	PLACA ELEC.2000W-220/I	NO	INOX	28/08/09
1	3218	CONMUTADOR 49.24215.520	NO	CU	28/08/09
1	340172P	EMBELLECEDOR MANDO GAS/ELECT.	NO	ABS	10/12/07
1	348173P	MANDO ELECTRICO	NO	BAQ	10/12/07
1	348173PM	CONJUNTO MANDO ELECTRICO	NO	BAQ+ABS	10/12/07
1	441601P	PLACA CREPERA D.380 PAVONADA	NO	FE 10	28/04/10
1	C4500019	ESPATULA CREPERA	NO	INOX	06/05/10
1	C4500029	DISPENSADOR CREPERA	NO	MADERA	10/05/11
1	C5120219	PILOTO REDONDO ROJO D.5.5	NO	CU	14/04/09
1	C5222199	CABLE 3X2.5 C/ENCHUFE	NO	CU	11/06/09
1	C5321009	PRENSAESTOPA PG-11	NO	PLASTICO	06/10/09
1	C5321089	TUERCA PG-11	NO	PLASTICO	06/10/09
4	C6260549	PATA PA M-10X30 BASE D.30	NO	PA NEGRA	15/04/10



FAMILIA: BAR 2009

FECHA: 03/05/10

MODELO: 4418

PESO(Kg): 18.722

DENOMINACION:  
CREPERA 1 PLACA ELEC.

ESCALA:  
1/6

MATERIAL:  
INOX

CODIGO:  
4418