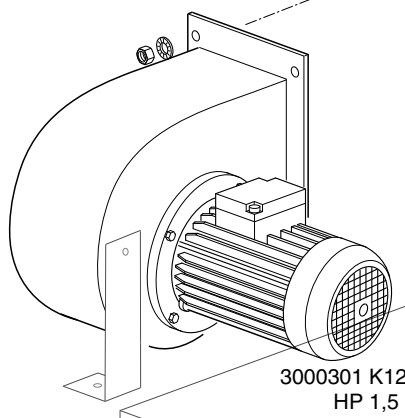
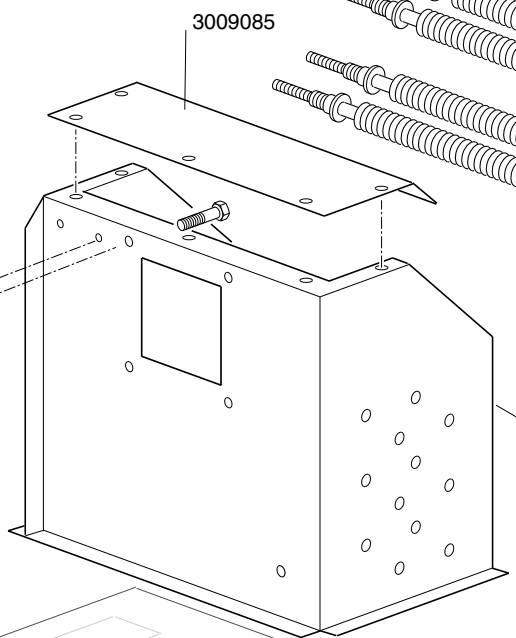
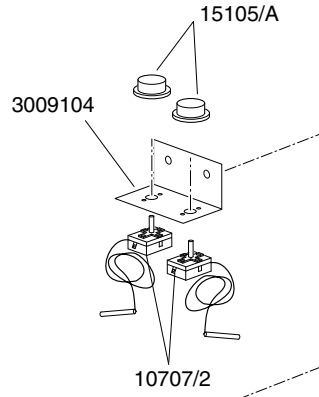
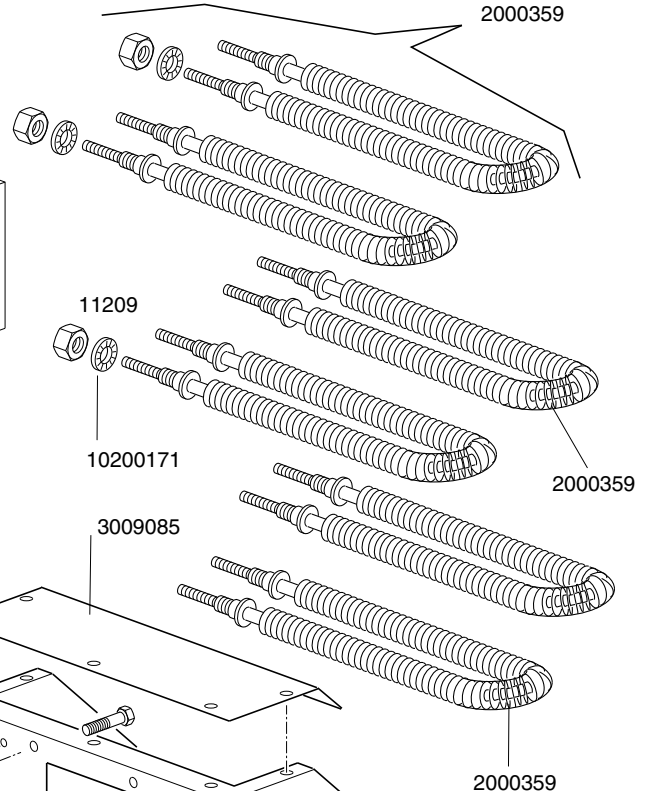
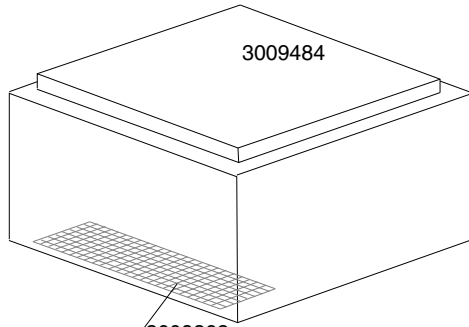
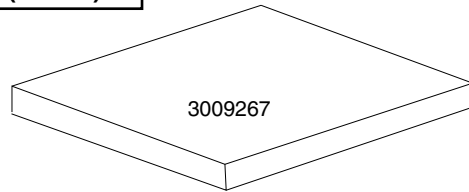
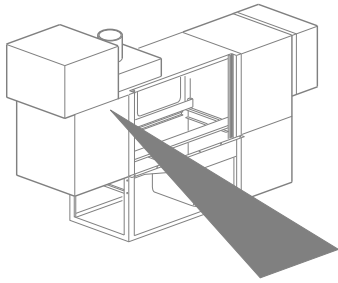
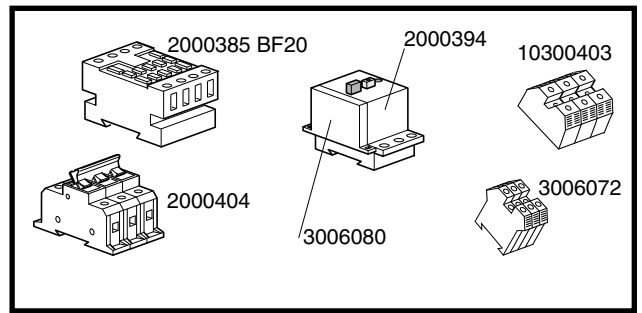

TABLE	REV
KI9115	00

OPTIONAL ASCIUG. K12 (12 Kw)

OPTIONAL DRYING K12 (12 Kw)



3009486 DX
3009487 SX

3009214

