

IPERLOTUS 90

CUCINE / RANGES / HERDE / CUISINIÈRES

CF...6-912

CF6-912GEV

	1	2	3	4	5	6
Vedi Pagina See Page Siehe Seite Voir Page Ver Pàgina	116	108	126	127	128	130

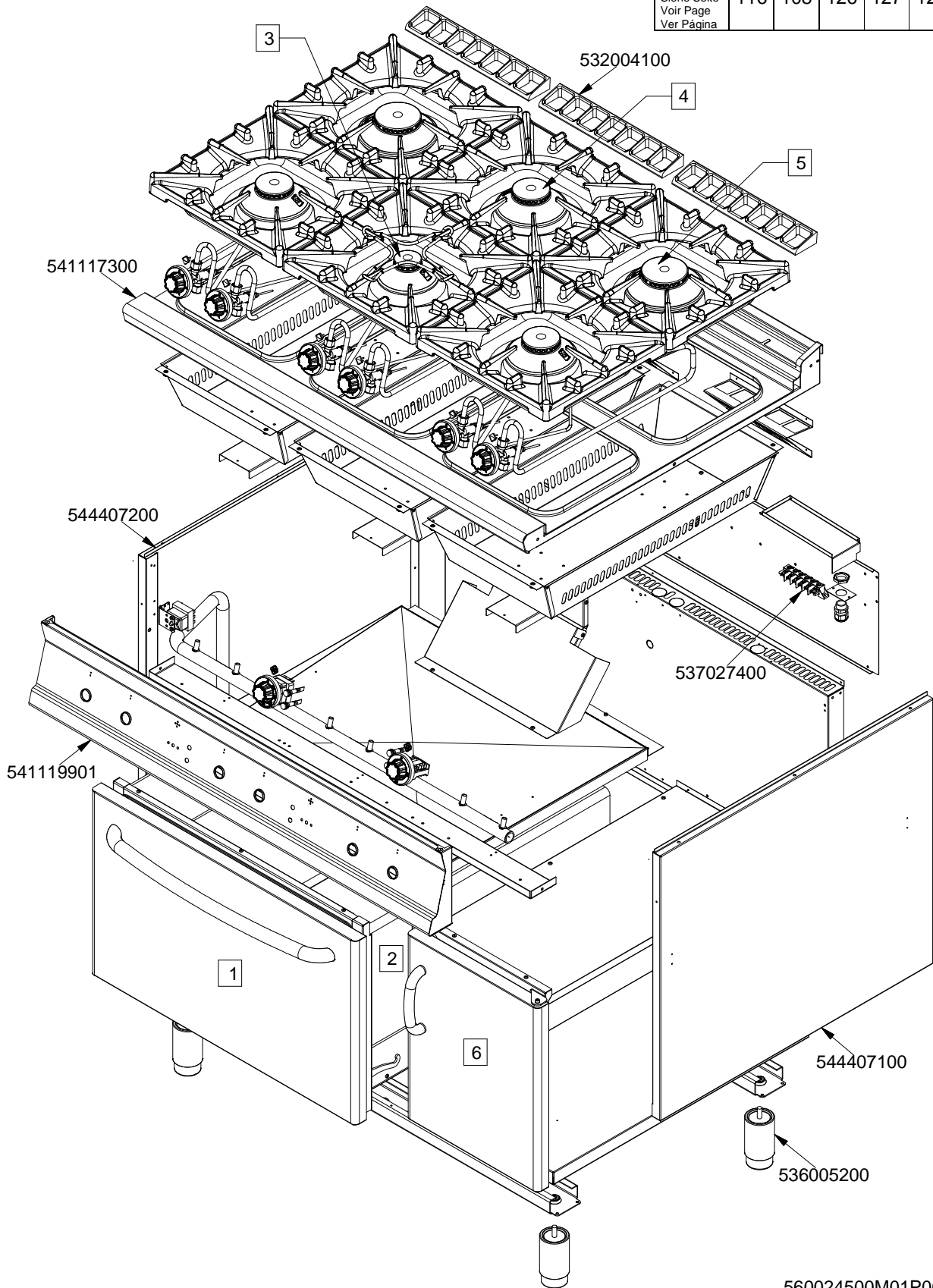

560024500M01P00.

IPERLOTUS 90

CUCINE / RANGES / HERDE / CUISINIÈRES
FORNO / OVEN / BACKOFEN / FOUR

PORTE / DOORS / TÜREN / PORTES

GN 2/1

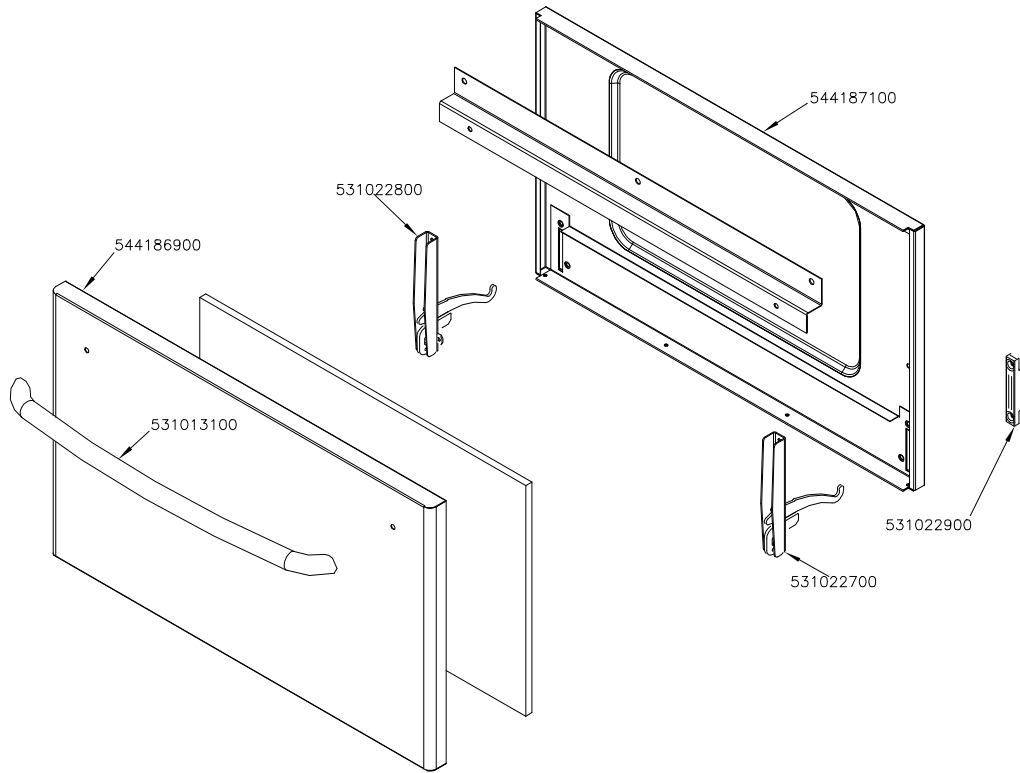

GN 3/1

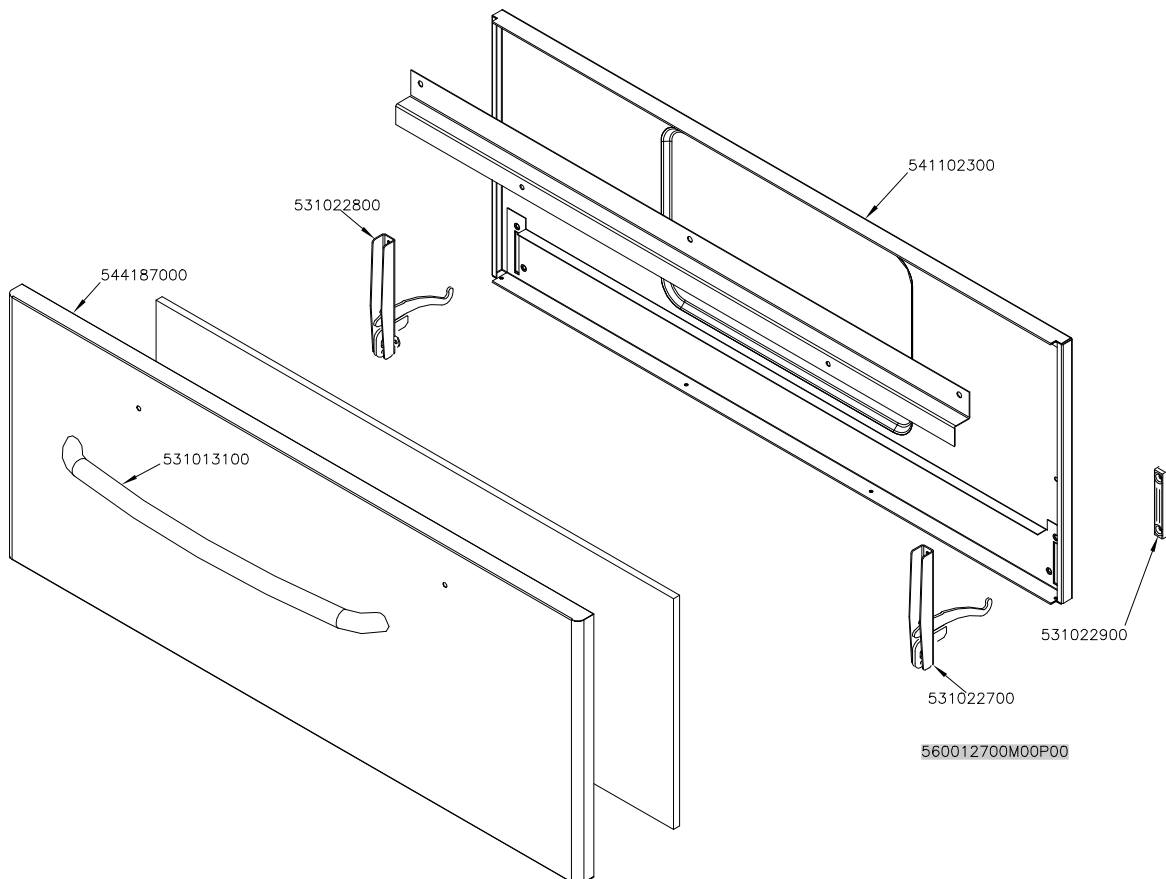

IPERLOTUS 90

CUCINE / RANGES / HERDE / CUISINIÈRES

FORNO / OVEN / BACKOFEN / FOUR

ELETRICO / ELECTRICAL / ELEKTRO / ELECTRIQUE / GN 2/1 / X

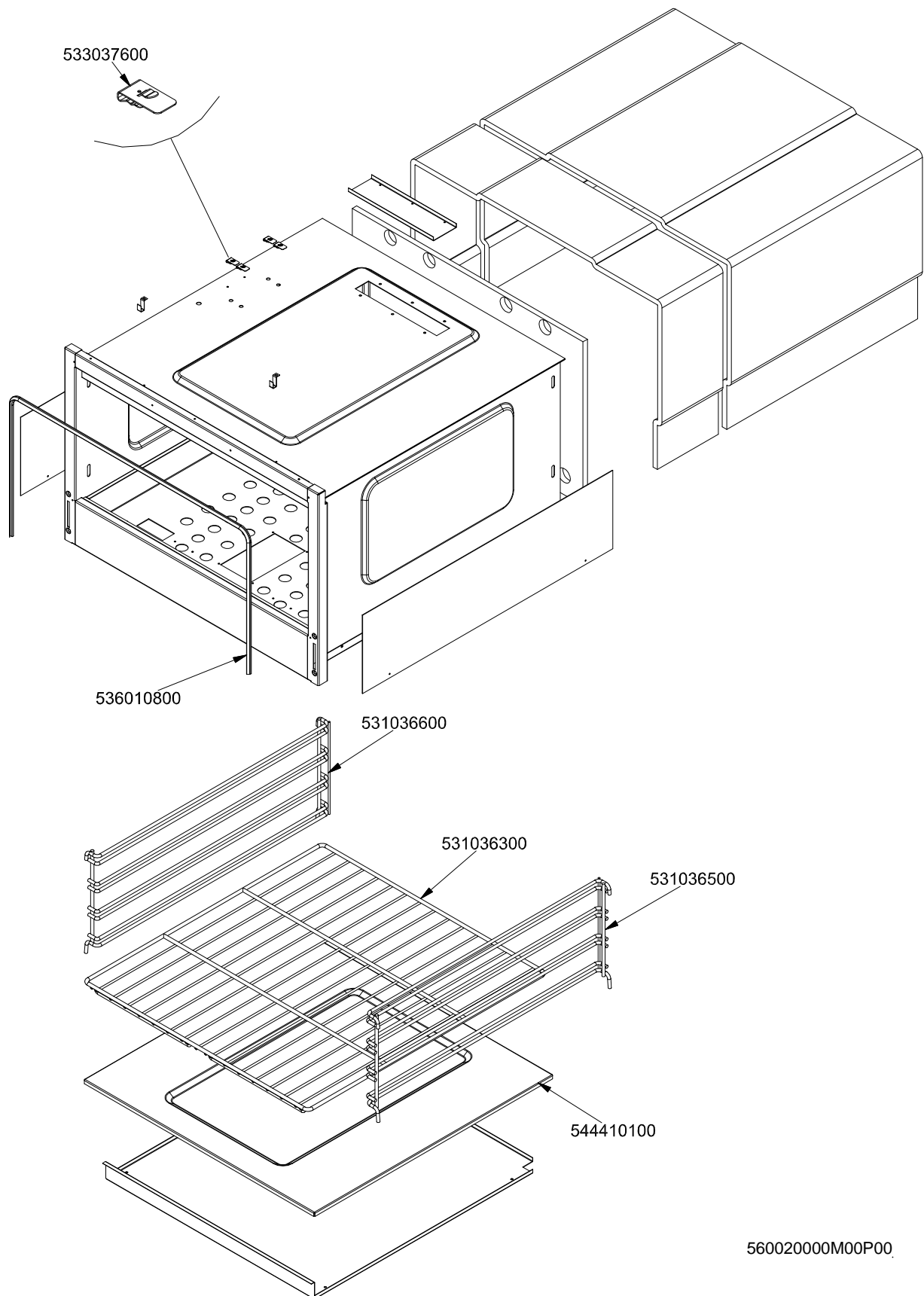

IPERLOTUS 90

CUCINE / RANGES / HERDE / CUISINIÈRES
FORNO / OVEN / BACKOFEN / FOUR

ELETTRICO / ELECTRICAL / ELEKTRO / ELECTRIQUE / GN 2/1 / X

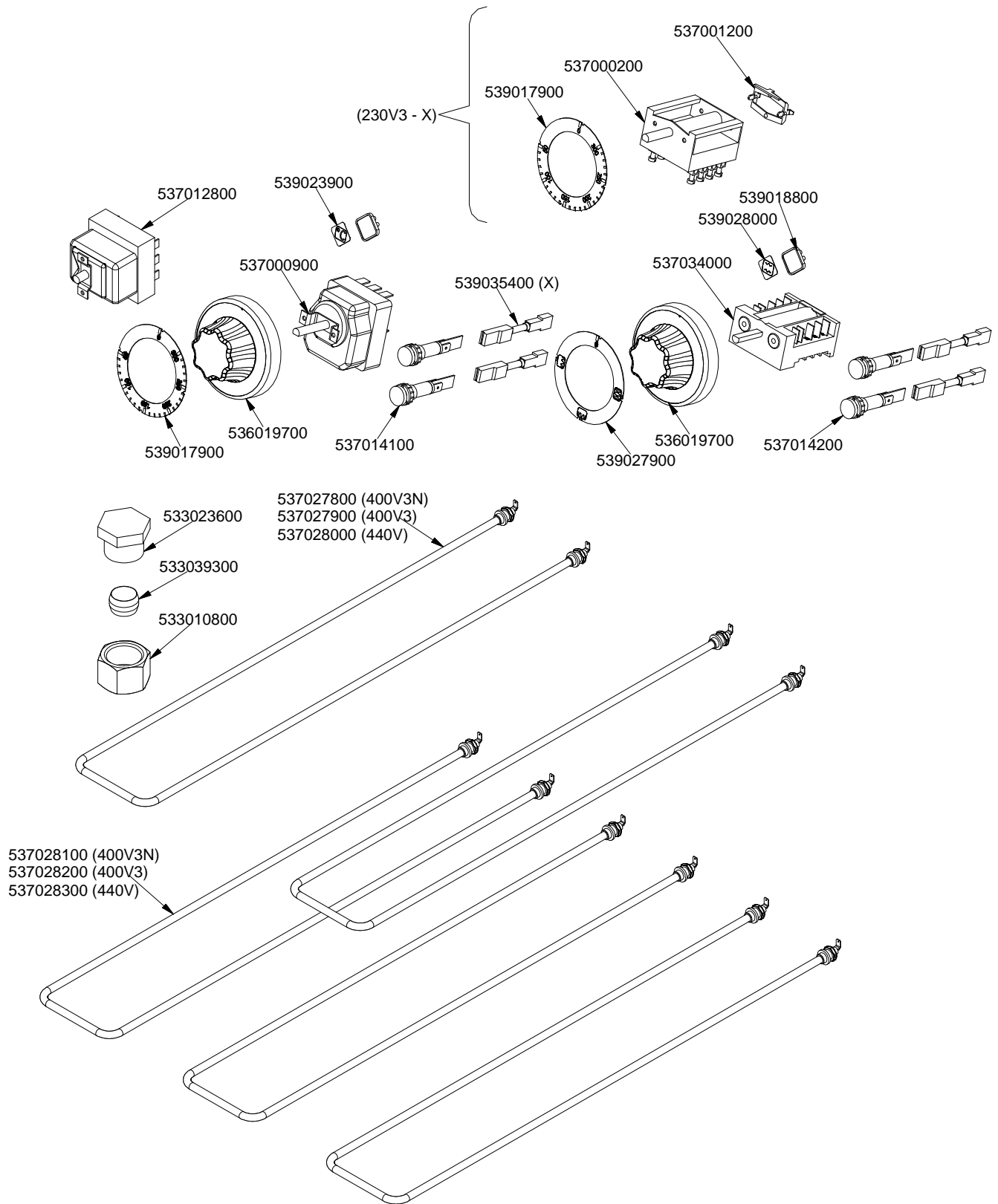

PC-G 4KW

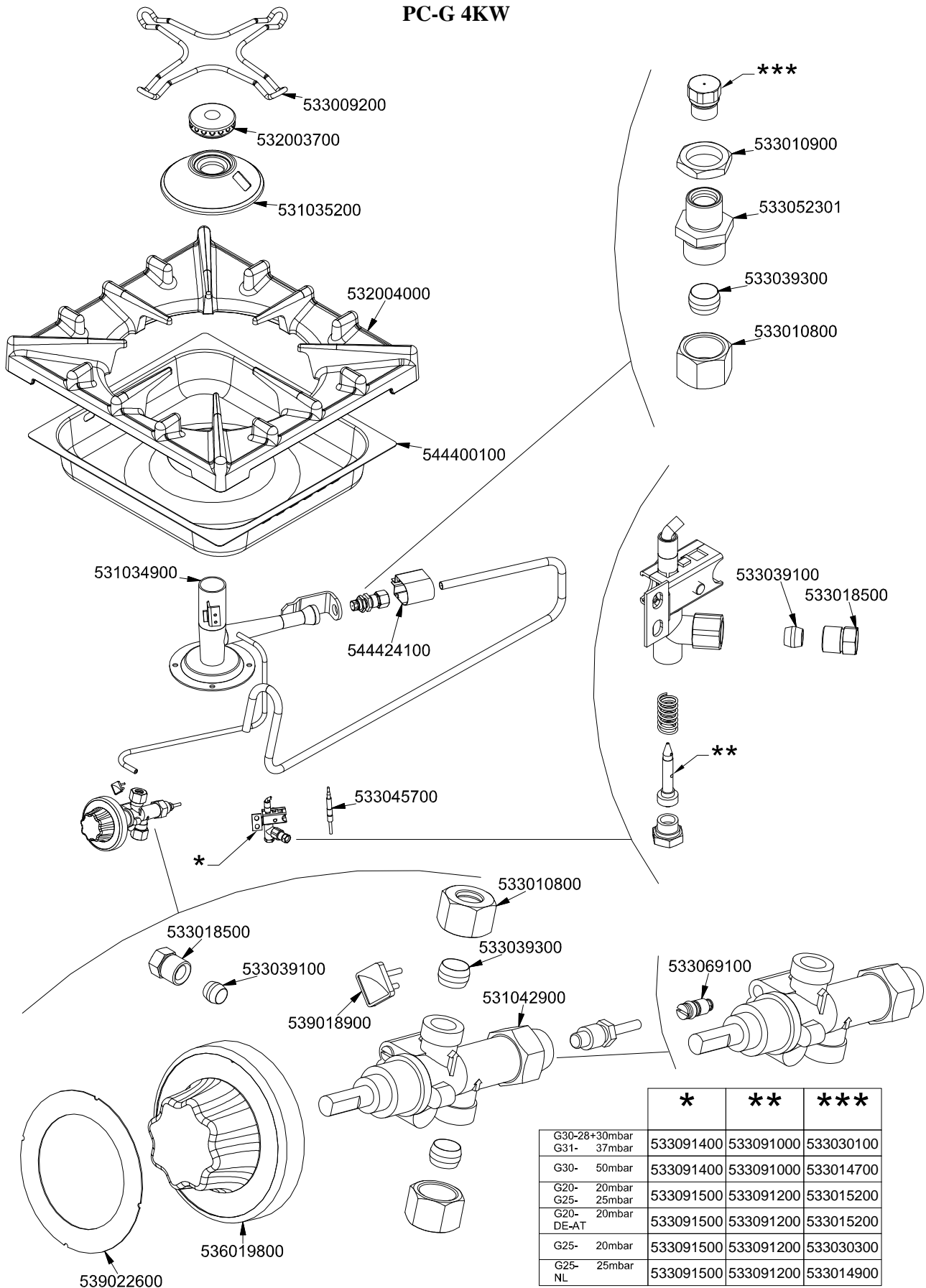

	*	**	***
G30-28+30mbar	533091400	533091000	533030100
G31- 37mbar			
G30- 50mbar	533091400	533091000	533014700
G20- 20mbar	533091500	533091200	533015200
G25- 25mbar			
G20- 20mbar	533091500	533091200	533015200
DE-AT			
G25- 20mbar	533091500	533091200	533030300
G25- 25mbar	533091500	533091200	533014900
NL			

560023100M00P00

PC-G 7KW

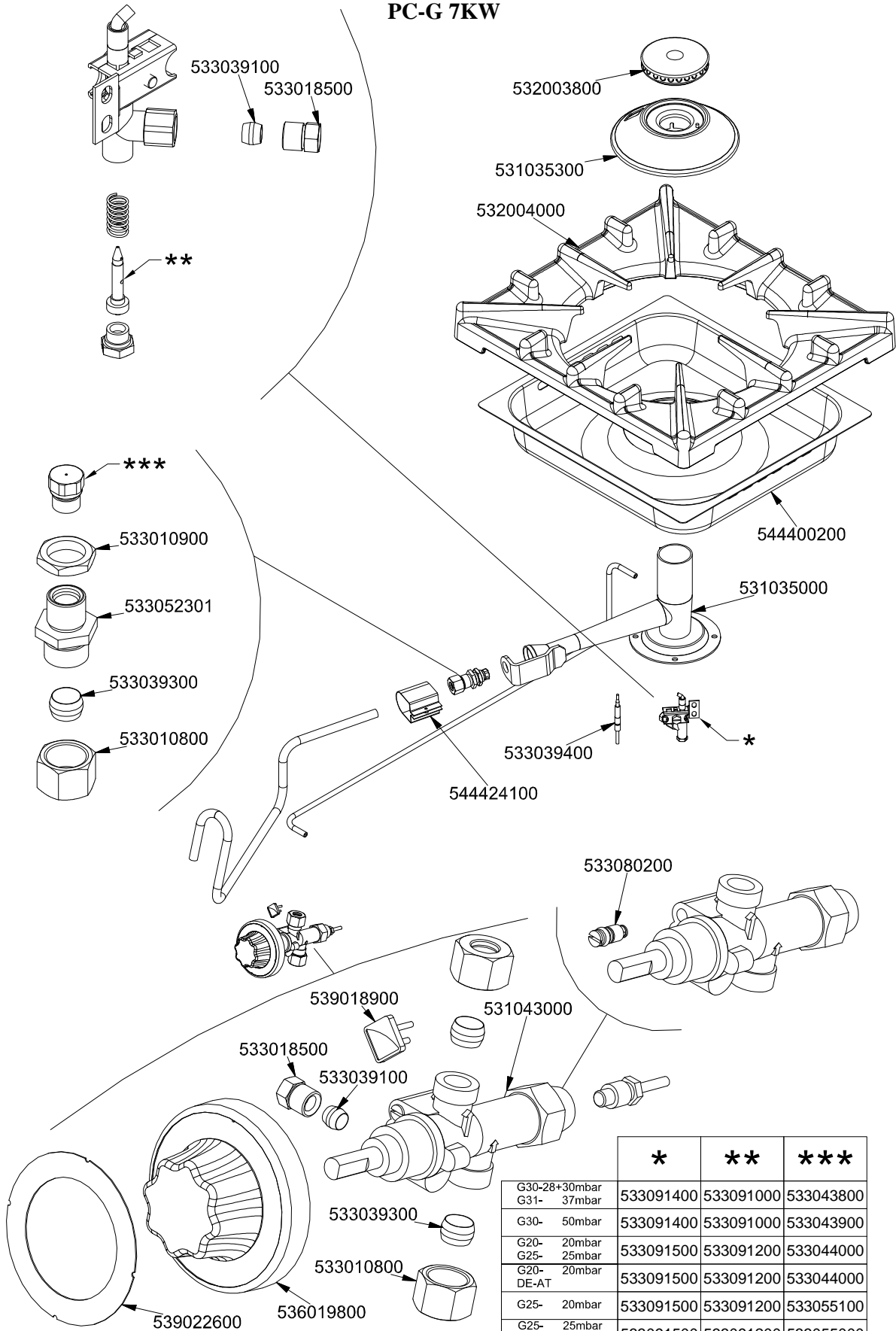

	*	**	***
G30-28+30mbar	533091400	533091000	533043800
G31- 37mbar			
G30- 50mbar	533091400	533091000	533043900
G20- 20mbar	533091500	533091200	533044000
G25- 25mbar			
G20- 20mbar DE-AT	533091500	533091200	533044000
G25- 20mbar	533091500	533091200	533055100
G25- 25mbar NL	533091500	533091200	533055000

560023200M00P00

IPERLOTUS 90

COMPONENTI COMUNI / STANDARDS PARTS / UEBLICHE TEILE / COMPOSANTS COMMUNS

PC-G 10KW

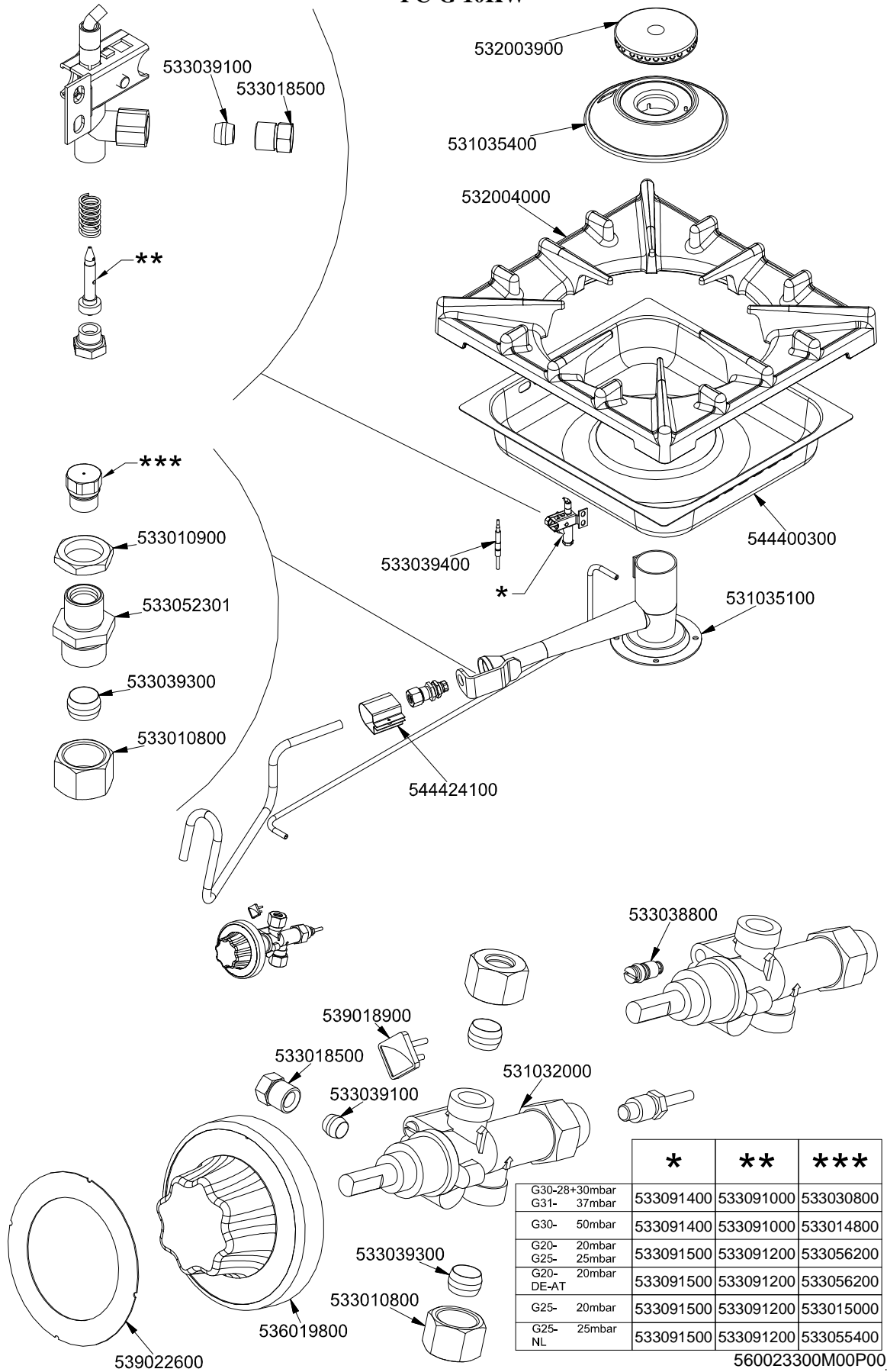

	*	**	***
G30-28+30mbar	533091400	533091000	533030800
G31- 37mbar			
G30- 50mbar	533091400	533091000	533014800
G20- 20mbar	533091500	533091200	533056200
G25- 25mbar			
G20- 20mbar	533091500	533091200	533056200
G25- 20mbar	533091500	533091200	533015000
G25- 25mbar	533091500	533091200	533055400

560023300M00P00

PORTE / DOORS / FLÜGELÜREN / PORTES N°≥0602

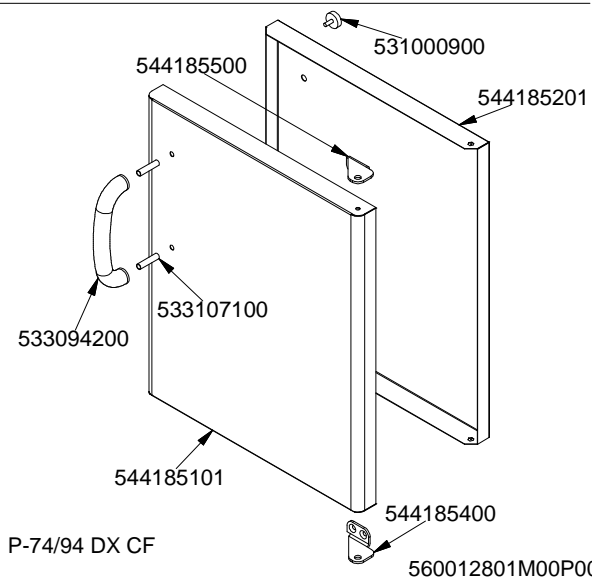
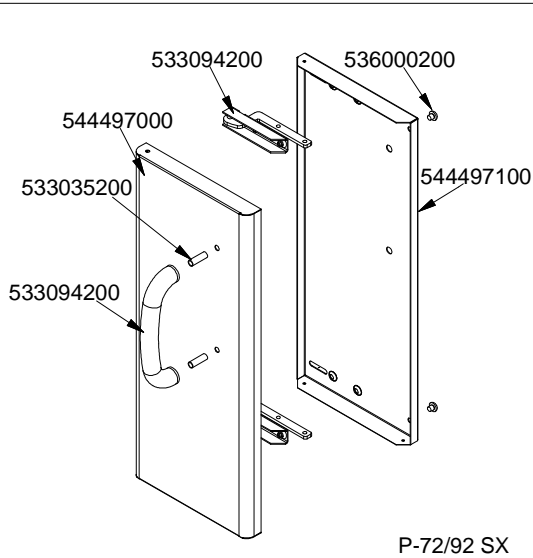
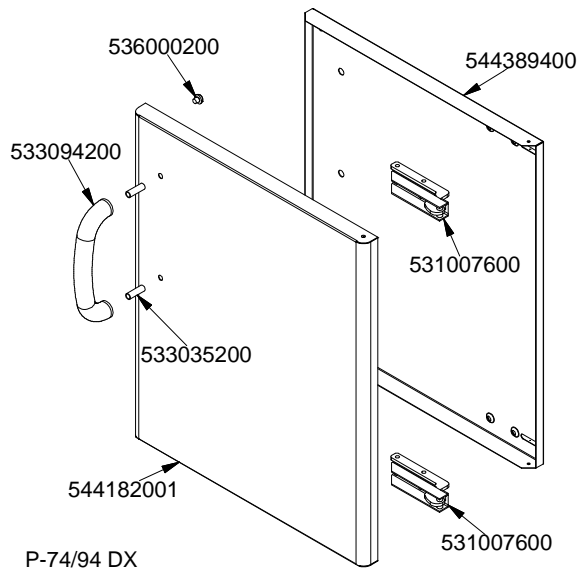
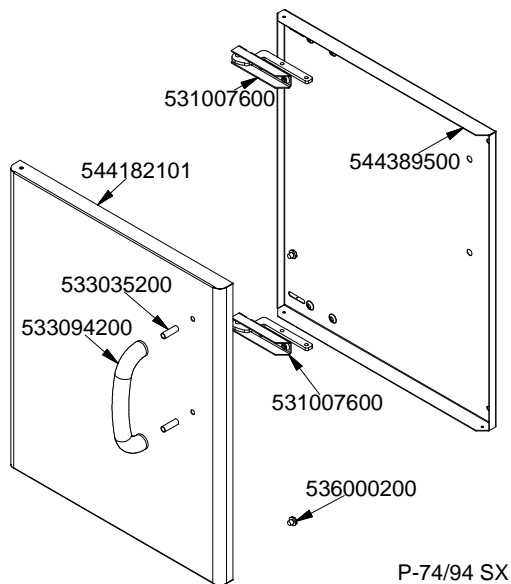
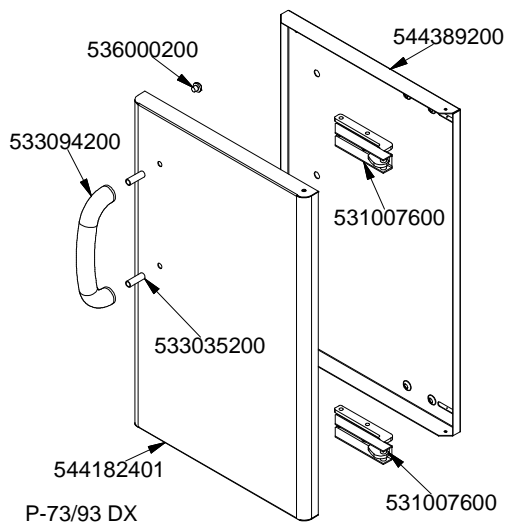
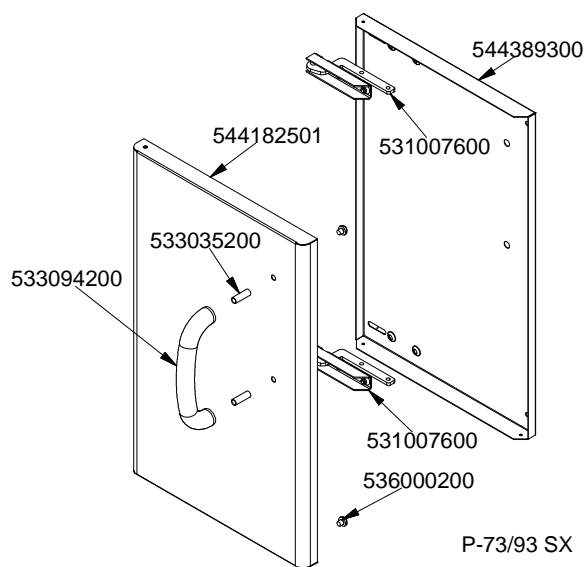

Page	Pos	Code	Description
001		544407100	RIGHT SIDE PANEL RANGE 90 LINE
001		536005200	INOX LEG 2" 120-180 M10
001		541119901	CONTROL PANEL S70/90 CF6-912G/GE
001		544407200	RIGHT SIDE PANEL RANGE 70 LINE
001		541117300	UPPER PLATE PC-912G CF6-912G/GE/GEV
001		537027400	TERMINAL BLOCK THREEPHASE 40A
001		532004100	FLUE GRID L=370 70LINE (RAF)
002		544187100	OVEN INNER DOOR GN 2/1 S.70
002		531022800	LEFT OVEN DOOR HINGE S.70
002		544156900	
002		531013100	OVEN DOOR HANDLE OF 70/90-LINE
002		531022900	HINGE DOOR WHEEL HOLDER S.70
002		531022700	RIGHT OVEN DOOR HINGE 70LINE
002		541102300	GAS OVEN INNER DOOR GN 3/1 S.70
002		531072800	
002		544187000	OVEN DOOR GN 3/1 S.70
003		533037600	LOCK SPRING FOR BULB
003		536010800	OVEN GASKET GN 2/1 (1261)
003		531036600	LHD RACK HOLDER FOR OVEN S.90
003		531036300	OVEN RACK GN 2/1 FOR 90 LINE
003		531036500	RHD RACK HOLDER FOR OVEN S.90
003		544410100	90 ELECTRICAL OVEN BOTTOM GN2/1
004		539018800	INDEX FOR OVEN KNOB
004		539028000	SELECTOR SIGN PLATE FOR OVEN
004		537034000	
004		536019700	BLACK KNOB §70 PIN §6*5
004		537014200	GREEN WARNING LIGHT 250V
004		537027800	OVENUPPER HEATING EL. W800 V230 90L
004		537012800	SAFETY THERMOSTAT 420°C THREEPHASE
004		539017900	ADHESIVE GRADUATED DISC FOR KNOB
004		537000900	THERMOSTAT 50-320°C THREEPHASE
004		539023900	SIGN PLATE FOR OVEN TEMPERATURE
004		537014100	WHITE WARNING LIGHT 250V
004		539027900	ADHESIV.GRADUATED DISC FOR SELECTOR
004		533023600	TAP PLUG §10 M16*1, 5CH19
004		533039300	BICONE §10
004		533010800	TUBE NUT D.10 M16*1,5
004		537000200	COMMUTATOR 1 POS. 3PHASE S.49 16A
004		537001200	FIXING BRACKET FOR THERMOSTAT/COMM.
004		539035400	
004		537027900	OVENUPPER HEATING EL. W800 V400 90L
004		537028000	OVENUPPER HEATING EL. W800 V440 90L
004		537028100	OVEN LOWER HEATING EL.W700 V230 90L
004		537028200	HEATING ELEMENT 1700W 230V OVEN S70
004		537028300	OVEN LOWER HEATING EL.W1700 V230 90
005		533091000	NOZZLE 0.100 §20
005		533091200	PILOT NOZZLE 0100 Ø35 PIL.PC
005		533030100	NOZZLE §95 CH12*14 G-FP
005		533014700	NOZZLE §85 CH12*14 F-FQ5
005		533015200	NOZZLE §145 CH12*14 F-FP/CP6
005		533030300	NOZZLE §160 CH12*14 M-FPG

Page	Pos	Code	Description
005		533014900	NOZZLE §150 CH12*14 F-FQ5 L-FQ6
005		533091400	P.NOZZLE S100 UG.§20 PC90 LPG-FLUS
005		533091500	PILOT NOZZLE S.100 §30 PC90 NAT.GAS
005		533009200	REDUCTION FOR 65 AND 70 LINE
005		532003700	BURNER COVER RING §060
005		531035200	SMALL BURNER BODY 90 LINE
005		532004000	1 FLAME GRILL 396X366 (90)
005		533010900	NUT M14*1 H.4
005		533052301	JOINT FOR NOZZLE HOLDER
005		533039300	BICONE §10
005		533010800	TUBE NUT D.10 M16*1,5
005		544400100	BURNER DRIP PAN 2/3
005		531034900	SMALL BURNER VENTURI 90 LINE
005		544424100	
005		533039100	BICONE §6
005		533018500	FITTING FOR BICONE D.6 M10*1
005		533045700	THERMOCOUPLE M9*1 500
005		539018900	INDEX FOR KNOB
005		536019800	BLACK KNOB §70 PIN §8*6,5
005		539022600	GRADUATED STICKER FOR KNOB
005		531042900	B.PASS §60 SAFETY COCK PC/CF 90
005		533069100	BY PASS COCK §60 20S
006		533091000	NOZZLE 0.100 §20
006		533091200	PILOT NOZZLE 0100 Ø35 PIL.PC
006		533091400	P.NOZZLE S100 UG.§20 PC90 LPG-FLUS
006		533091500	PILOT NOZZLE S.100 §30 PC90 NAT.GAS
006		533043800	NOZZLE §130 CH12*14 G-CW4
006		533043900	NOZZLE §115 CH12*14 F-CW4
006		533044000	NOZZLE §195 CH12*14 M-CW4
006		533055100	NOZZLE §215 CH12*14 L-CW4
006		533055000	NOZZLE §205 CH12*14 G25 CW4
006		533039100	BICONE §6
006		533018500	FITTING FOR BICONE D.6 M10*1
006		532003800	BURNER COVER RING §082
006		531035300	MEDIUM BURNER BODY 90 LINE
006		532004000	1 FLAME GRILL 396X366 (90)
006		544400200	BURNER DRIP PAN 2/3
006		531035000	MEDIUM BURNER VENTURI 90 LINE
006		533039400	THERMOCOUPLE M9*1*850
006		544424100	
006		533010900	NUT M14*1 H.4
006		533052301	JOINT FOR NOZZLE HOLDER
006		533039300	BICONE §10
006		533010800	TUBE NUT D.10 M16*1,5
006		533080200	BY PASS COCK §65 20S-21S
006		539018900	INDEX FOR KNOB
006		531043000	GAS COCK 21S P.V. BY-PASS §065
006		536019800	BLACK KNOB §70 PIN §8*6,5
006		539022600	GRADUATED STICKER FOR KNOB
007		533091000	NOZZLE 0.100 §20
007		533091200	PILOT NOZZLE 0100 Ø35 PIL.PC

Page	Pos	Code	Description
007		533091400	P.NOZZLE S100 UG.§20 PC90 LPG-FLUS
007		533091500	PILOT NOZZLE S.100 §30 PC90 NAT.GAS
007		533030800	NOZZLE §155 CH12X14 M-CW
007		533014800	NOZZLE §135 CH12*14,0
007		533056200	NOZZLE §230 CH12*14
007		533015000	NOZZLE D.I 260 G110 (TOWN GAS)
007		533055400	NOZZLE §245 CH12*14
007		533039100	BICONE §6
007		533018500	FITTING FOR BICONE D.6 M10*1
007		532003900	BURNER COVER RING §100
007		531035400	BIG BURNER BODY 90 LINE
007		532004000	1 FLAME GRILL 396X366 (90)
007		533010900	NUT M14*1 H.4
007		533052301	JOINT FOR NOZZLE HOLDER
007		533039300	BICONE §10
007		533010800	TUBE NUT D.10 M16*1,5
007		533039400	THERMOCOUPLE M9*1*850
007		544400300	BURNER DRIP PAN 2/3
007		531035100	BIG BURNER VENTURI 90 LINE
007		544424100	
007		533038800	75 BY-PASS FOR 21S TAP
007		539018900	INDEX FOR KNOB
007		531032000	GAS COCK P.V.BY-PASS Ø075
007		536019800	BLACK KNOB §70 PIN §8*6,5
007		539022600	GRADUATED STICKER FOR KNOB
008		544389300	
008		531007600	DOOR HINGE
008		544182501	LEFT DOOR 73
008		533035200	
008		533094200	S/S HANDLE FOR 70/90 SERIES
008		536000200	D.12 H.4 BUMPER
008		544182401	RIGHT DOOR 73
008		544389200	
008		544182001	RIGHT DOOR 74
008		544389400	
008		544182101	LEFT DOOR 74
008		544389500	INNER-DOOR OF LHD 74
008		544497100	
008		544497000	
008		544185101	RIGHT DOOR 74 CF
008		544185400	LOWER DOOR HINGE FOR COMPARTME CF70
008		533107100	
008		544185500	UPPER DOOR HINGE FOR COMPARTME CF70
008		531000900	MAGNET §22 KG.3 WITH DISK
008		544185201	