

C4FFE
C4FFEP
CCTPFE8
C6FFE
C6FFEP
C2FTPFE
C2FTPFEF

A = GPL / LP gas / Gaz liquide / Flüssiggas
B = Gas metano / Natural gas / Gaz naturel / Erdgas



N.B.: La tavola si completa con la successiva n° E05-045
N.B.: See table No. E05-045
N.B.: Voir tableau n° E05-045
Wichtig: S. folgender Plan Nr. E05-045

E05-042

C4FFE - C6FFE - C4FFEP - C6FFEP
CCTPFE8 - C2FTPFE - C2FTPFEF

Ed. 07/01

Rev. 3

Pezzi/Pieces Pieces/Anzahl							Pos.	Validità dalla matricola Validité du numéro matricule Validity from serial number Gültigkeit ab der (Seriennummer)	Validità alla matricola Validity up to serial number Validité au numéro matricule Gültigkeit bis zur (Seriennummer)	Codice Code Artikel Nummer	Descrizione	Description	Description	Beschreibung
C4FFE	C6FFE	C4FFEP	C6FFEP	C2TFPE8	C2TFPFE	C2TFPFEF								
2	2	2	4		1	1	1		X21600	Spartifiamma 3,5 kw	Flame spreader 3,5 kw	Diffuseur de flamme 3,5 kw	Flammenverteiler 3,5 kw	
		2	4			1	2		0900X22200	Corpo bruciatore 3,5 kw C/PIL.	U. R. Burner body 5,5 kw no pilot	Corps bruleur U. R. 5,5 kwS/Veill.	Brennerkörper. 5,5 kw	
				1	1	1	3		0903X20900	Bruciatore tuttapiastra	Grilling plate burner	Bruleur plaque unique	Herdplattenbrenner	
2	3	2	3	1	2	2	4		X14100	Termocoppia posteriore+T.P.	Rear ring thermocouple+G.P.	Thermocouple feu post.+P.U.	Thermoel. Hintere Kochst.+H.P.	
				1	1	1	5		X13500	Pilota	Pilot	Veilleuse d'allumage	Zündflammenbrenner	
				1	1	1	6		X14600	Candeletta	Ignition plug	Bougie	Glühkerze	
4	6			1	3	1	7		M00500	Piezo elettrico	Piezo-electric ignition	Piezo électrique	Piezoelektrischer zünder	
				1	1	1	8		1000x00800	Manopola	Knob	Cle de commande	Drehknopf	
2	2	2	2	2	2	2	9		Y03500	Supporto maniglia	Handle support	Support poignee	Griffträger	
1	1	1	1	1	1	1	10		B86900	Tubo maniglia	Handle pipe	Tube poignee	Griffhülse	
				1	1	1	11		0000Y21400	Rubinetto tuttapiastra	Grilling plate cock	Bruleur plaque unique	Gashahn Herdplatte	
		4	6			2	12		0000X00800	Manopola fuoco con pilota	Gas ring knob with pilot	Cle de comm. Feu avec veill.	Drehnopf Kochst.M./ Zundfl.	
		2	2			1	13		2000x10500	Rubinetto fuoco pilota 5,5 kw	Gas ring cock W/Pilot 5,5 kw	Robinet feu Av/Veill. 5,5 kw	Gashahn koch.+Zündfl. 5,5 kw	
2	3	2	3		1	1	14		X13900	Termocoppia anteriore	Thermocouple	Thermocouple	Thermoelement	
		2	4			1	15		3000x10500	Rubinetto fuoco 3,5 kw C/Pil.	Gas ring cock 3,5 kw pilot	Robinet feu 3,5 kw Av/Veill.	Gashahn kochst 3,5 kw M/Zündfl.	
				1	1	1	16A		Y09800	Iniettore gpl T.P.	Lpg injector G.P.	Injecteur gpl P.U.	Gasdüse gpl H.P.	
				1	1	1	16B		Y09900	Iniettore metano T.P.	Natural gas injector G.P.	Injecteur methane P.U.	Gasdüse methan herdpl. H.P.	
2	2	2	2		1	1	17A		X34000	Iniettore gpl fuoco 5,5 kw	Ring lpg injector 5,5 kw	Injecteur gaz feu 5,5 kw	Gasdüse gpl kochst 5,5 kw	
2	2	2	2		1	1	17B		X35400	Iniettore metano 5,5 kw	Natural gas injector 5,5 kw	Injecteur methane 5,5 kw	Gasdüse methan 5,5 kw	
2	2	2	2		1	1	18		X21700	Spartifiamma 5,5 kw	Flame spreader 5,5 kw	Diffuseur de flamme 5,5 kw	Flammenverteiler 5,5 kw	
2	3	2	3		1	1	19		0550X25000	Griglia smaltata	Enamel. Grid	Grille emaillee	Lackiert. Brennerrost	
		2	2			1	20		0900X22100	Corpo bruciatore 5,5 kw C/Pil.	Burner body 5,5 kw with pilot	Corps bruleur 5,5 kw Av/Veill.	Brennerk. 5,5 kw M/Zündfl.	
2	3	2	3		1	1	21		0550B84400F	Bacinella	Tray	Cuvette	Becken	
2	2	2	2		1	1	22		0900X21400	Venturi bruciatore 5,5 kw	Burner venturi 5,5 kw	Venturi bruleur 5,5 kw	Venturi brenner 5,5 kw	
		4	6			2	23		Y20300	Pilota	Pilot	Veilleuse d'allumage	Zündflammenbrenner	
		4	6			2	24		X19901	Regolatore aria	Air regulator	Regleur d'air	Luftregler	
		4	6			2	25		X19900	Corpo pilota	Pilot body	Corps veilleuse d'allumage	Körper Zündflammenbrenner	
4	6	4	6	1	3	3	26		0000X16100	Porta iniettore	Injector-holder	Porte-injecteur	Düsenräger	
2	4	2	4		1	1	27A		X33600	Iniettore gpl fuoco 3,5 kw	Ring lpg injector 3,5 kw	Injecteur gaz feu 3,5 kw	Gasdüse gpl kochst 3,5 kw	
2	4	2	4		1	1	27B		X34700	Iniettore metano 3,5 kw	Natural gas injector 3,5 kw	Injecteur methane 3,5 kw	Gasdüse methan 3,5 kw	
4	4	4	4	4	4	4	28		X61000	Piedino	Foot	Pied	Fuss	
2	4	2	4		1	1	29		0900X21300	Venturi bruciatore 3,5 kw	Burner venturi 3,5 kw	Venturi bruleur 3,5 kw	Venturi brenner 3,5 kw	
				1	1	1	30		X20200	Boccola registro aria	Air-regulation bush	Douille de reglage de l'air	Luftreglerbuchse	
				1	1	1	31		X41000	Cavo per piezo	Piezo-electric cable	Cable pour piezo	Kabel für pizozünder	

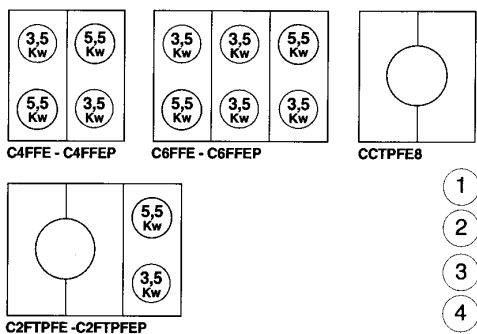
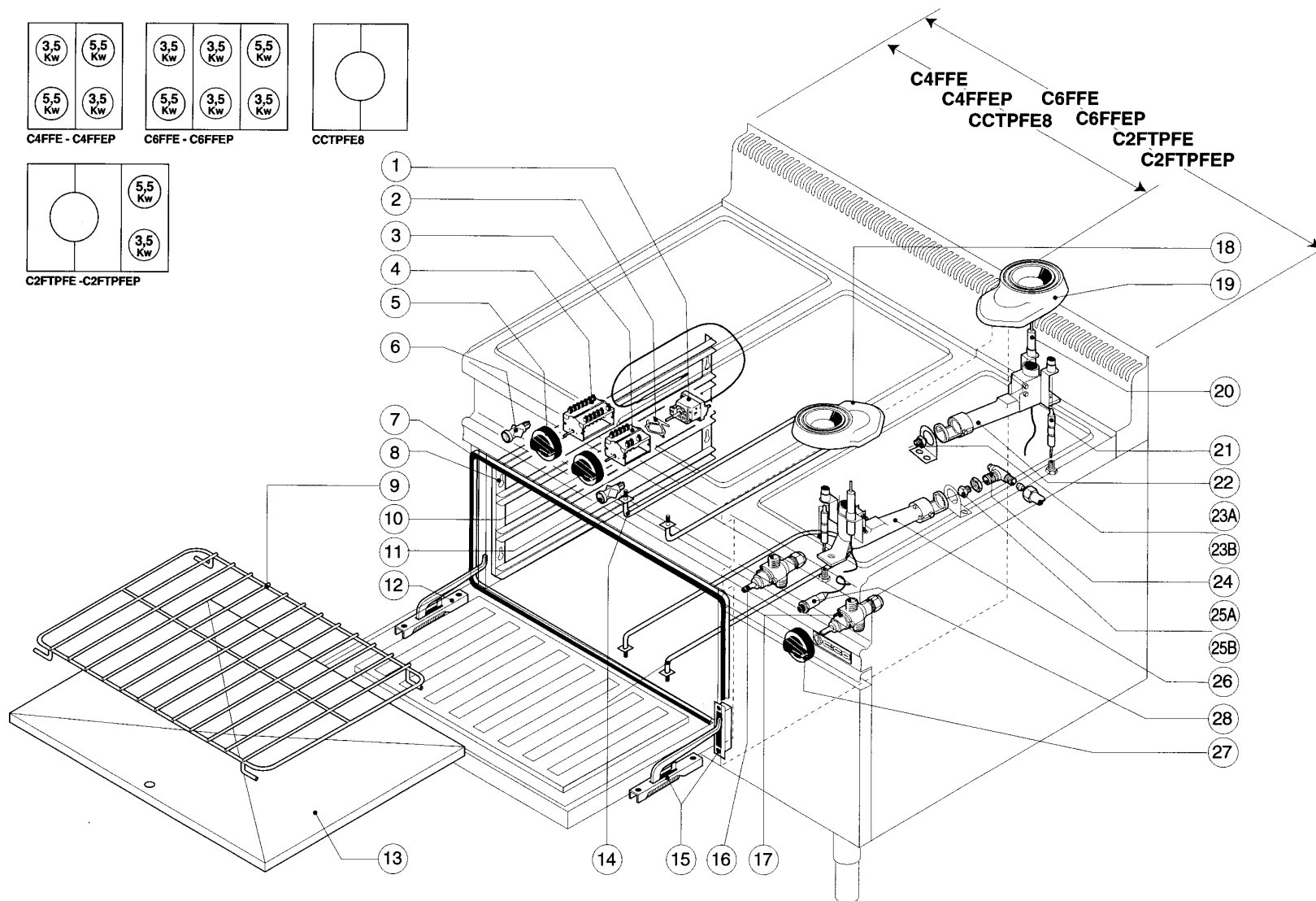

A = GPL / LP gas / Gaz liquide / Flüssiggas
 B = Gas metano / Natural gas / Gaz naturel / Erdgas



N.B.: La tavola si completa con la precedente n° E05-042
 N.B.: See table No. E05-042
 N.B.: Voir tableau n° E05-042
 Wichtig: S. vorheriger Plan Nr. E05-042

E05-045

C4FFE - C6FFE - C4FFE - C6FFE
 CCTPFE8 - C2FTPF - C2FTPF

Ed. 07/01

Rev. 1

Pezzi/Pieces Pieces/Anzahl							Pos.	Validità dalla matricola Validité du numéro matricule Validity from serial number Gültigkeit ab der (Seriennummer)	Validità alla matricola Validity up to serial number Validité au numéro matricule Gültigkeit bis zur (Seriennummer)	Codice Code Artikel Nummer	Descrizione	Description	Description	Beschreibung
C4FFE	C6FFE	C4FFEP	C6FFEP	C2TPFE8	C2FTPE	C2FTPEP								
1	1	1	1	1	1	1	1		X43200	Termostato 50-300°C forno	Oven thermostat 50-300°C	Thermostat 50-300°C four	Thermostat 50-300°C Ofen	
1	1	1	1	1	1	1	2		X44600	Staffa per collegamento	Connecting bracket	Collier de raccordement	Anschlussbügel	
1	1	1	1	1	1	1	3		X49700	Commutatore	Selector switch	Commutateur	Schalter	
1	1	1	1	1	1	1	4		X44100	Commutatore 4 posizioni	4-Pos. selector switch	Commutateur 4 positions	4 Positionenschalter	
1	1	1	1	1	1	1	5		0000X01200	Manopola commutatore	Selector knob	Bouton commutateur	Umschaltknopf	
1	1	1	1	1	1	1	6		X41200	Lampada gialla	Yellow light	Lampe jaune	Gelbe Kontrollampe	
1	1	1	1	1	1	1	7		0000X05600	Guarnizione porta	Door seal	Joint porte	Türdichtung	
2	2	2	2	2	2	2	8		B85500	Reggigriglia dx-sx	L.H.-R.H. Grid support	Appui grille droite/gauche	Rostauflegeschiene R.-L.	
1	1	1	1	1	1	1	9		G21P	Griglia	Grid	Grille	Rost	
1	1	1	1	1	1	1	10		0000X03700	Manopola commutatore	Selector knob	Bouton commutateur	Umschaltknopf	
1	1	1	1	1	1	1	11		X50900	Lampada verde	Green light	Lampe vert	Grüne Kontrollampe	
1	1	1	1	1	1	1	12		X66100	Cerniera sx	L. H. Hinge	Charniere gauche	Scharnier Links	
1	1	1	1	1	1	1	13		B88700	Suola	Floor	Sole	Boden	
6	6	6	6	6	6	6	14		X47000	Resistenza	Resistance	Resistance	Resistenz	
1	1	1	1	1	1	1	15		X66000	Cerniera dx	R. H. Hinge	Charniere droite	Scharnier Rechts	
2	2				1		16		2000X10100	Rubinetto fuoco 5,5 kW	Gas ring cock 5,5 kW	Robinet feu 5,5 kW	Gashahn Kochstelle 5,5 kW	
2	4				1		17		1000X10100	Rubinetto fuoco 3,5 kW	Gas ring cock 3,5 kW	Robinet feu 3,5 kW	Gashahn Kochstelle 3,5 kW	
2	4				1		18		0900X21000	Corpo bruciatore 3,5 kW s/pil.	Burner body 3,5 kW no pilot	Corps bruleur 3,5 kW S/Veill.	Brennerk. 3,5 kW ohne Zündfl.	
2	2				1		19		0900X21100	Corpo bruciatore 5,5 kW s/pil.	Burner body 5,5 kW no pilot	Corps bruleur 5,5 kW S/Veill.	Brennerk. 5,5 kW ohne Zündfl.	
4	6				2		20		X14500	Candeletta	Ignition plug	Bougie	Glühkerze	
2	3	2	3	1	2	2	21		X14100	Termocoppia posteriore	Rear ring thermocouple	Thermocouple feu posterieure	Thermoel. Hintere Kochst.	
2	2	2	2		1	1	22		0900X21400	Venturi bruciatore 5,5 kW	Burner venturi 5,5 kW	Venturi bruleur 5,5 kW	Venturi Brenner 5,5 kW	
2	2	2	2		1	1	23A		X34000	Iniettore GPL fuoco 5,5 kW	Ring LPG injector 5,5 kW	Injecteur gaz feu 5,5 kW	Gasdüse GPL Kochst 5,5 kW	
2	2	2	2		1	1	23B		X35400	Iniettore metano 5,5 kW	Natural gas injector 5,5 kW	Injecteur methane 5,5 kW	Gasdüse Methan 5,5 kW	
4	6	4	6	1	3	3	24		0000X16100	Porta iniettore	Injector-holder	Porte-injecteur	Düsenträger	
2	4	2	4		1	1	25A		X33600	Iniettore GPL fuoco 3,5 kW	Ring LPG injector 3,5 kW	Injecteur gaz feu 3,5 kW	Gasdüse GPL Kochst 3,5 kW	
2	4	2	4		1	1	25B		X34700	Iniettore metano 3,5 kW	Natural gas injector 3,5 kW	Injecteur methane 3,5 kW	Gasdüse Methan 3,5 kW	
2	4	2	4		1	1	26		0900X21300	Venturi bruciatore 3,5 kW	Burner venturi 3,5 kW	Venturi bruleur 3,5 kW	Venturi Brenner 3,5 kW	
4	6				2		27		0000X00100	Manopola fuoco senza pilota	Gas ring knob no pilot	Cle de comm. feu s/veill.	Drehknopf kochst. ohne Zündfl.	
4	6			1	3	1	28		M00500	Piezo elettrico	Piezo-electric ignition	Piezo electrique	Piezoelektrischer Zünder	