

NME1254R & FME1504R SERVICE PARTS

This parts list contains the part numbers and descriptions of the service parts for the NME1254R and FME1504R remote ice machines.

Note: The liquid line filter drier listed in this parts list is designed for this refrigeration system. Premature failure may result if the wrong drier is used.

Table of Contents

PANELS	2
REFRIGERATION	3
NME EVAPORATOR	4
FME EVAPORATOR	5
CONTROL BOX	6
GEARMOTOR	7
RESERVOIR, DRAINS, ICE CHUTE, ICE LEVEL SENSORS	8
REMOTE CONDENSER	9
WIRING DIAGRAMS	10

NME1254R & FME1504R SERVICE PARTS PANELS

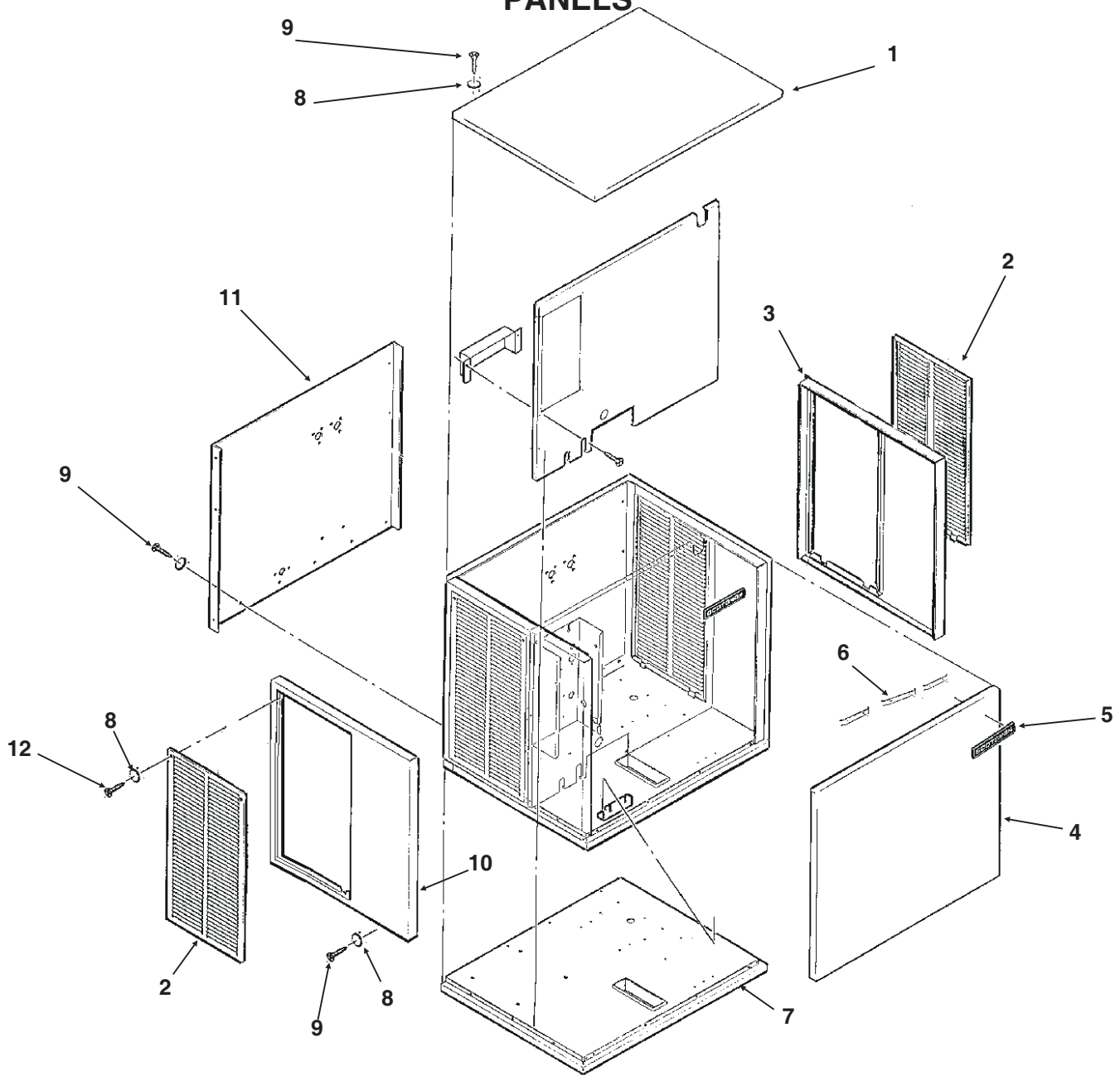

ITEM NUMBER	PART NUMBER	DESCRIPTION	ITEM NUMBER	PART NUMBER	DESCRIPTION
1.	A32159-002	Top Panel Stainless	9.	03-1531-01	Screw
2.	A33946-032	Service Panel for S.S.	10.	A32163-002	Left End Panel S.S.
3.	A32162-002	Right End Panel S.S.	11.	A32201-003	Back panel, ss
4.	A32160-002	Front Panel S.S.	12.	03-1404-12	Screw
5.	15-0808-01	Emblem			
6.	03-0271-00	Clip For Emblem (3)			
7.	A35955-001	Base Assembly			
8.	03-1417-27	Washer			

NME1254R & FME1504R SERVICE PARTS REFRIGERATION

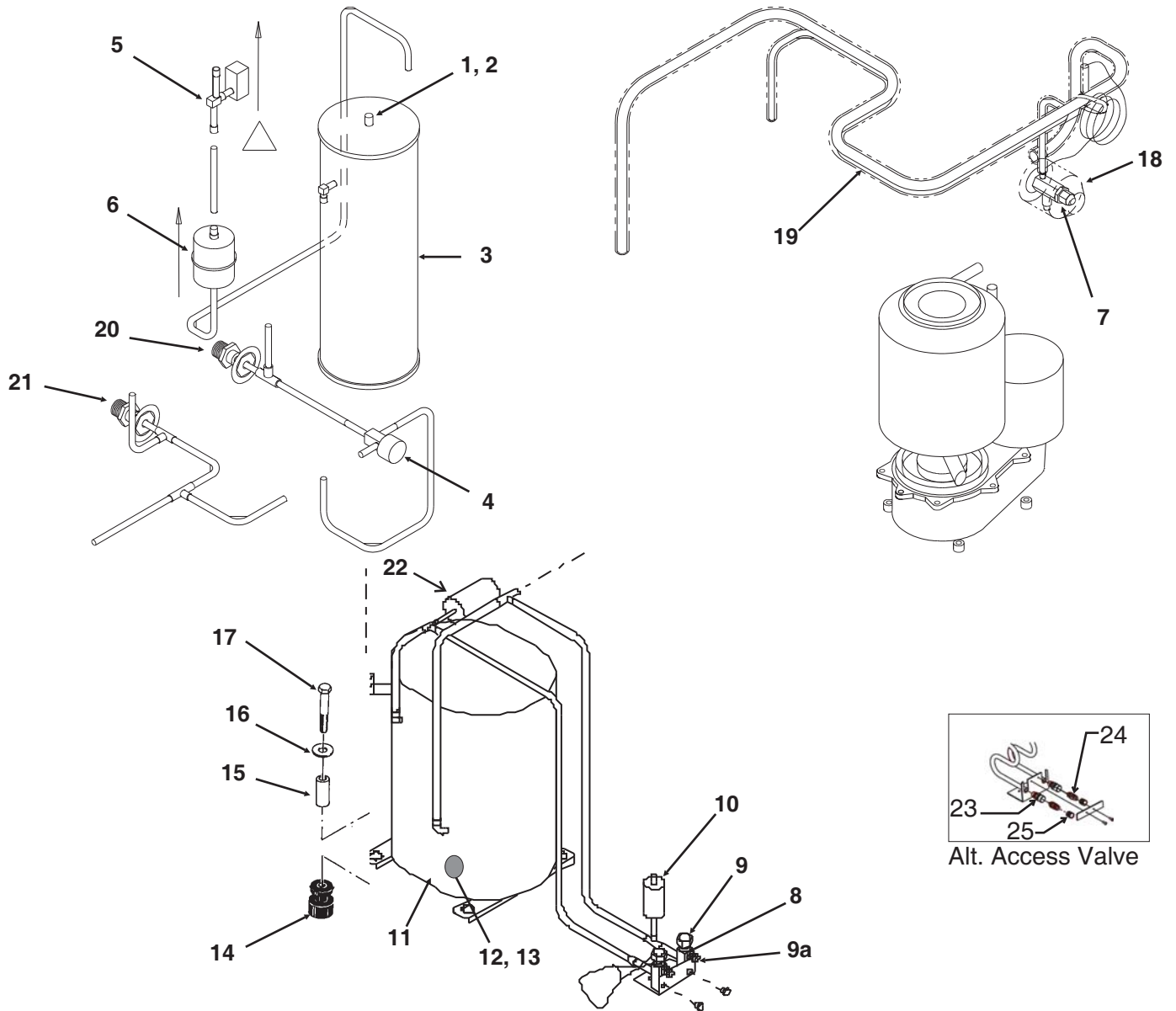

ITEM NUMBER	PART NUMBER	DESCRIPTION
1.	03-1406-13	Nut
2.	03-1410-06	Washer
3.	16-0761-01	Receiver
4.	11-0422-25	Lo Temp Valve
5.	12-2135-02	Liquid Line Valve
6.	02-3319-02	Drier
7.	11-0482-21	Thermo. Exp. Valve
8.	16-0832-20	Access valve
9.	16-0832-02	Stem cap
9a.	16-0832-03	Core cap
10.	11-0501-22	High Press. Switch
11.	18-8726-23	Compressor 208-230/60/1 (includes item 12)
12.	12-2308-01	Heater - internal
	12-1868-03	Heater - external
13.	12-2309-01	clip

ITEM NUMBER	PART NUMBER	DESCRIPTION
14.	18-2200-28	Grommet
15.	18-2200-27	Sleeve
16.	03-1407-07	Washer
17.	03-1405-20	Bolt
18.	A31961-020	TXV insulation
19.	no number	Suction line
20.	16-0850-03	Quick connect, 3/8"
21.	16-0850-01	Quick connect, 1/2"
Not shown, parts to attach receiver:		
	03-1645-01	Screw
	03-1417-09	Washer
	A31801-002	Lower Bracket
22.	11-0502-21	Low pressure cut out
23.	16-1137-01	Access valve body
24.	16-1139-01	Core
25.	16-1140-01	Cap

NME1254R & FME1504R SERVICE PARTS NME EVAPORATOR

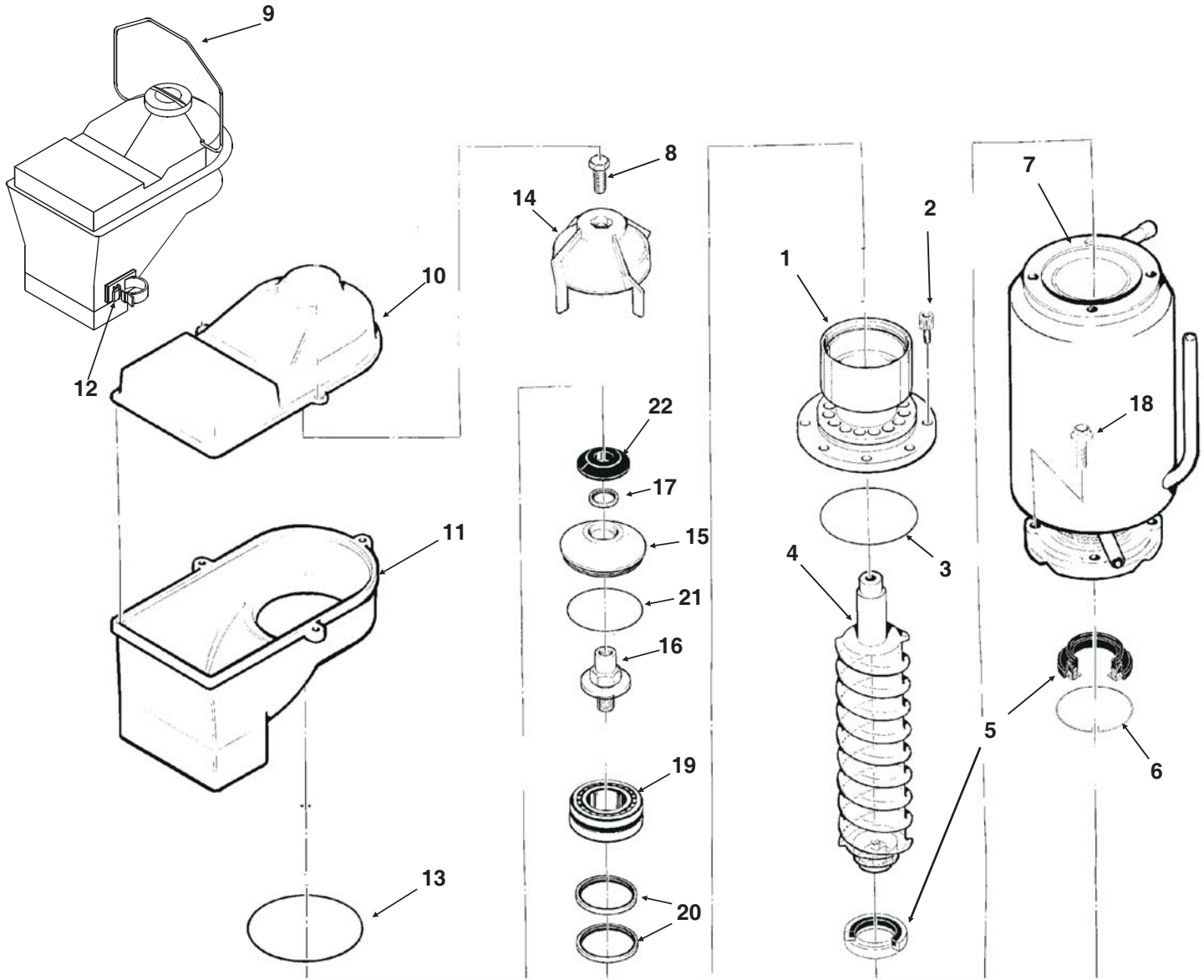

ITEM NUMBER	PART NUMBER	DESCRIPTION	ITEM NUMBER	PART NUMBER	DESCRIPTION
1.	A32900-020	Breaker & bearing	10.	02-2930-04	Ice Chute Cover
2.	03-1544-08	Soc. head Screw	11.	02-2926-01	Ice Chute Body
3.	13-0617-45	O-ring	12.	02-3268-01	Drain hose clip
4.	A38071-022	Auger	13.	13-0617-52	O-ring
5.	02-0929-23	Water Seal	14.	02-3001-01	Ice Sweep
6.	A32777-001	Ring, Water Seal	15.	02-3128-20	Breaker Cover
7.	A32890-020	Evaporator	16.	08-0660-01	Auger Stud
8.	03-1405-52	Hex Cap Screw	17.	02-2978-01	Lip Seal
9.	A34969-001	Bail clamp	18.	03-1420-03	Cap screw
Note: Evaporator is not available with internal parts.			19.	A34559-020	Bearing
			20.	02-2977-01	Lip Seal
			21.	13-0617-54	O-Ring
			22.	13-0871-01	Water Shed

NME1254R & FME1504R SERVICE PARTS FME EVAPORATOR

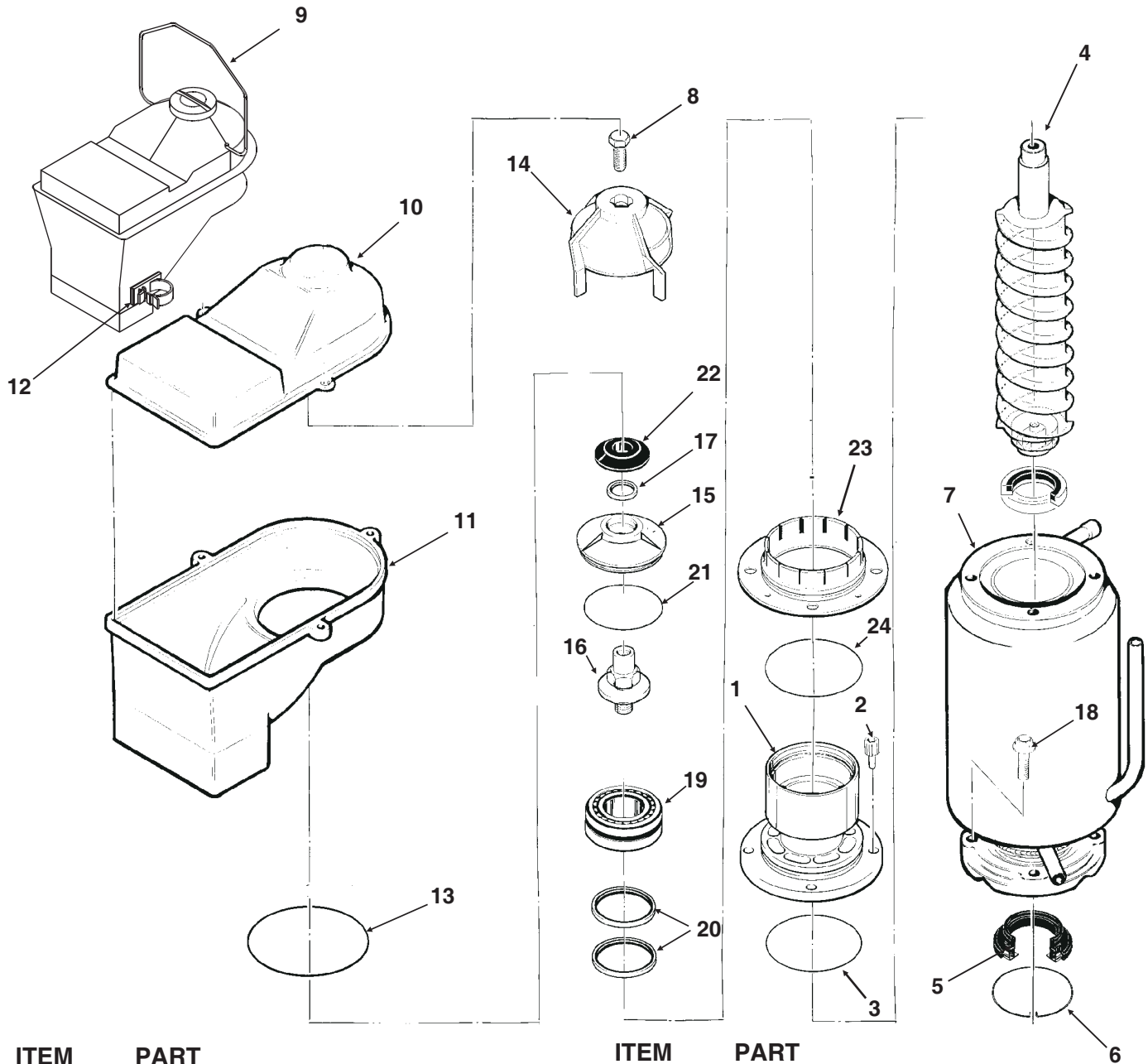

ITEM NUMBER	PART NUMBER	DESCRIPTION
1.	A34505-020	Breaker Includes Items 19 & 20
2.	03-1544-08	Soc. head Screw
3.	13-0617-45	O-ring
4.	A38071-022	Auger
5.	02-0929-23	Water Seal
6.	A32777-001	Ring, Water Seal
7.	A32890-020	Evaporator
8.	03-1405-52	Hex Cap Screw
9.	A34969-001	Bail clamp
10.	02-2930-04	Ice Chute Cover
11.	02-2926-01	Ice Chute Body

ITEM NUMBER	PART NUMBER	DESCRIPTION
12.	02-3268-01	Drain hose clip
13.	13-0617-52	O-ring
14.	02-3001-01	Ice Sweep
15.	02-3128-20	Breaker Cover
16.	08-0660-20	Auger Stud
17.	02-2978-01	Lip Seal
18.	03-1420-03	Cap screw
19.	A34559-020	Bearing
20.	02-2977-01	Lip Seal
21.	13-0617-54	O-Ring
22.	13-0871-01	Water Shed
23.	02-2916-01	Slotted collar
24.	13-0617-49	O-ring

Note: Evaporator is not available assembled with internal parts.

NME1254R & FME1504R SERVICE PARTS CONTROL BOX

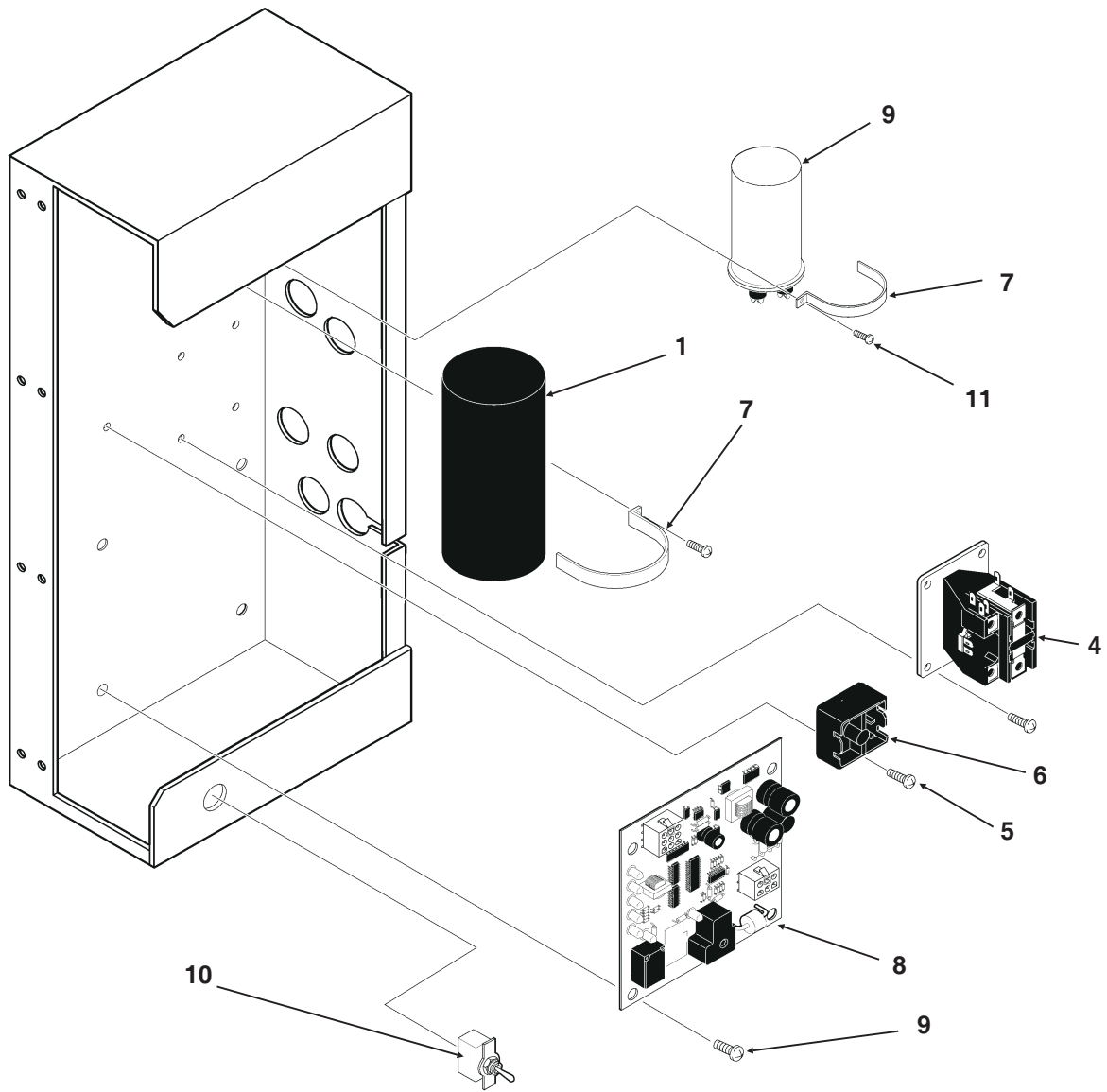

ITEM NUMBER	PART NUMBER	DESCRIPTION
1.	18-1901-15	Start Capacitor
2.	18-1902-53	Run Capacitor
3.	A35971-001	Start Cap. Bracket
4.	12-2469-02	1 Phase Contactor
5.	03-1638-03	Screw
6.	18-1903-33	Relay
7.	A35971-002	Run Cap. Bracket
8.	12-2835-21	Circuit Board
9.	12-2350-01	Stand off
10.	12-0426-01	Mode switch

NME1254R & FME1504R SERVICE PARTS GEARMOTOR

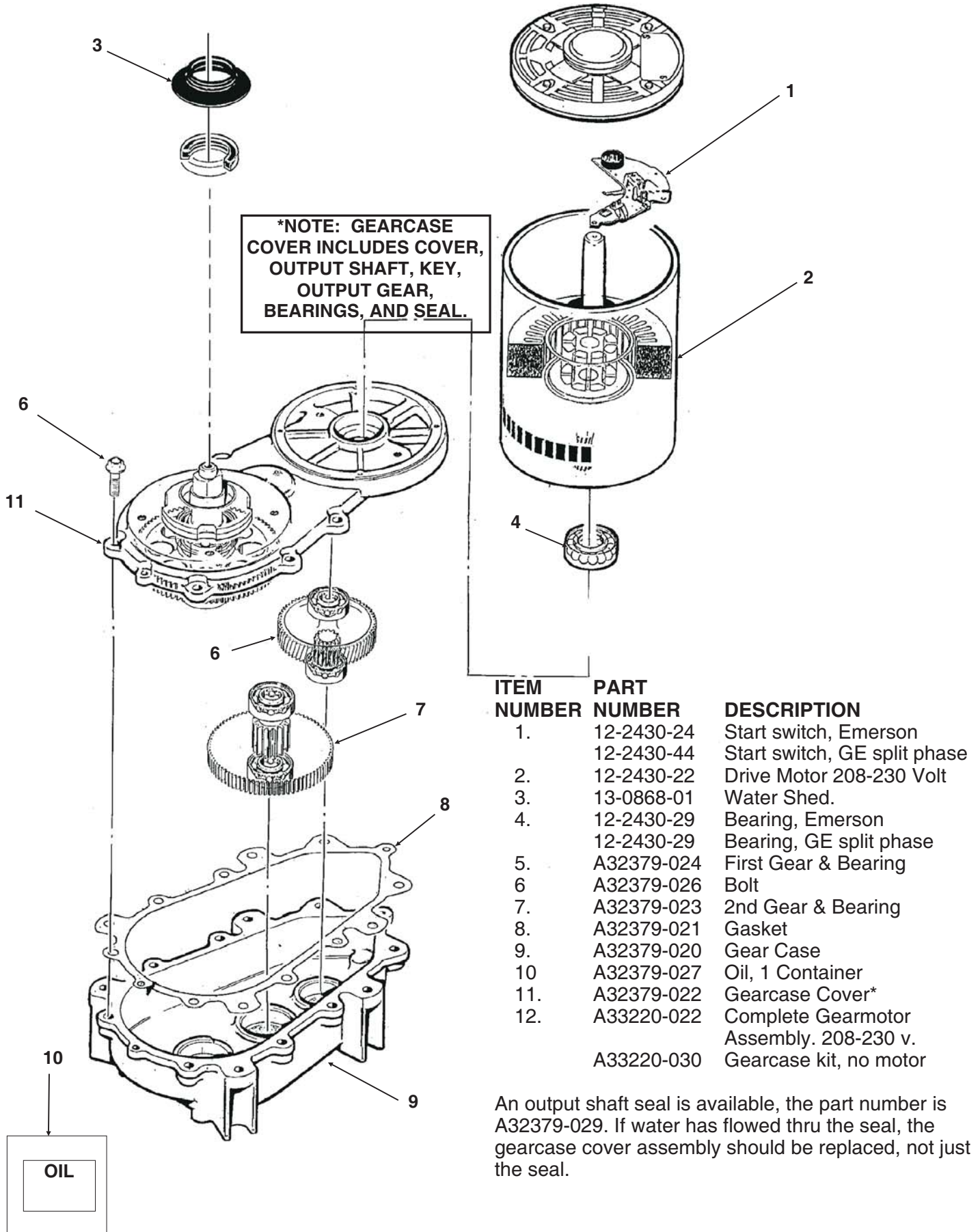

NME1254R & FME1504R SERVICE PARTS

RESERVOIR, DRAINS, ICE CHUTE, ICE LEVEL SENSORS

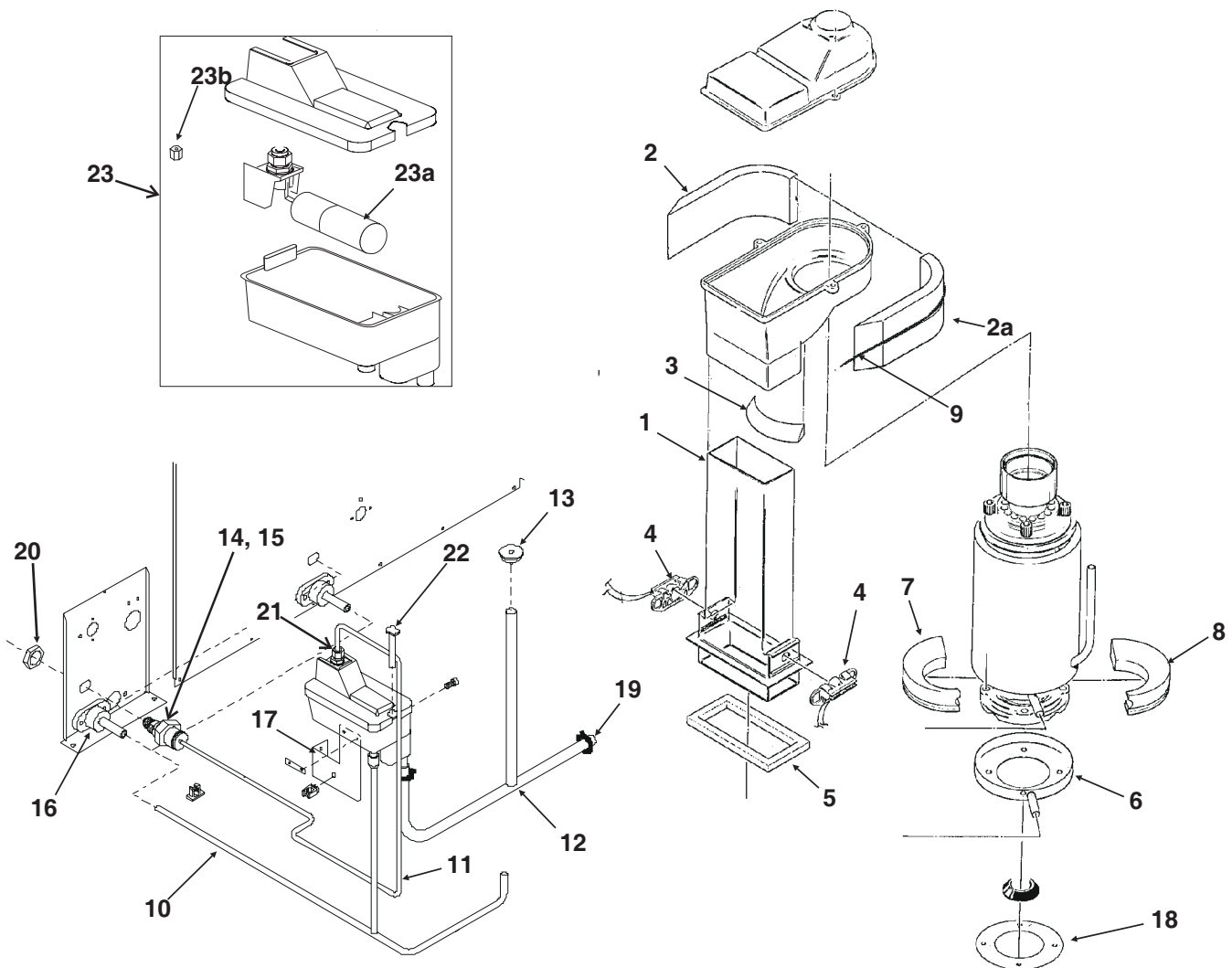

ITEM NUMBER	PART NUMBER	DESCRIPTION	ITEM NUMBER	PART NUMBER	DESCRIPTION
1.	02-2929-04	Ice Chute Lower	16.	02-3692-22	Drain fitting
2.	A32963-002	Insulation collar top	17.	A35956-015	Reservoir bracket
2a	A32963-001	Insulation collar, top	18.	13-0704-00	Drip pan gasket
3.	A33102-001	Insulation Collar Inside	19.	02-1338-00	Hose clamp
4.	A37708-021	Ice level sensor set	20.	03-1394-01	Pal Nut
5.	A32930-001	Chute Gasket	21.	16-0871-01	Brass insert
6.	02-3837-01	Drip Pan	22.	12-2760-21	Water level sensor
7.	A32962-001	Insulation Collar Bottom	23.	02-3266-20	Float & Reservoir complete
8.	A32962-002	Insulation Collar Bottom	23a	02-3266-21	Float valve
9	A35419-020	Strap kit	23b	02-3266-03	Seat/plunger
10.	02-3836-01	Drain hose			
11.	13-0895-01	Inlet tube, 4 ft req.			
12.	A36154-002	Preformed Hose			
13.	13-0840-01	Plug			
14.	16-0835-01	Water inlet fitting			
15.	16-1039-01	Male connector			

NME1254R & FME1504R SERVICE PARTS REMOTE CONDENSER

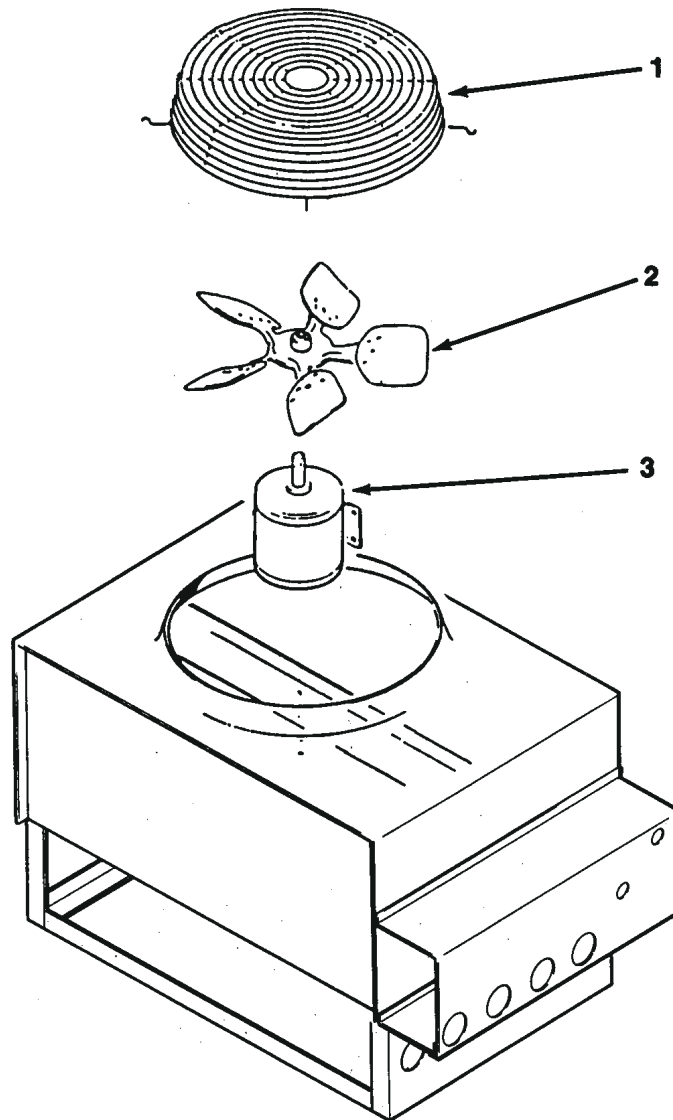

ERC201 or ERC402

ITEM NUMBER	PART NUMBER	DESCRIPTION
1	02-3575-01	Fan guard
2	18-8800-01	Fan blade
3	18-8796-32	Fan motor

For precharged line set:

16-1057-01	Female coupling (3/8")
16-1057-02	Female coupling (1/2")

NME1254R & FME1504R SERVICE PARTS Component Layout Diagram

208-230/60/1

17-2683-01

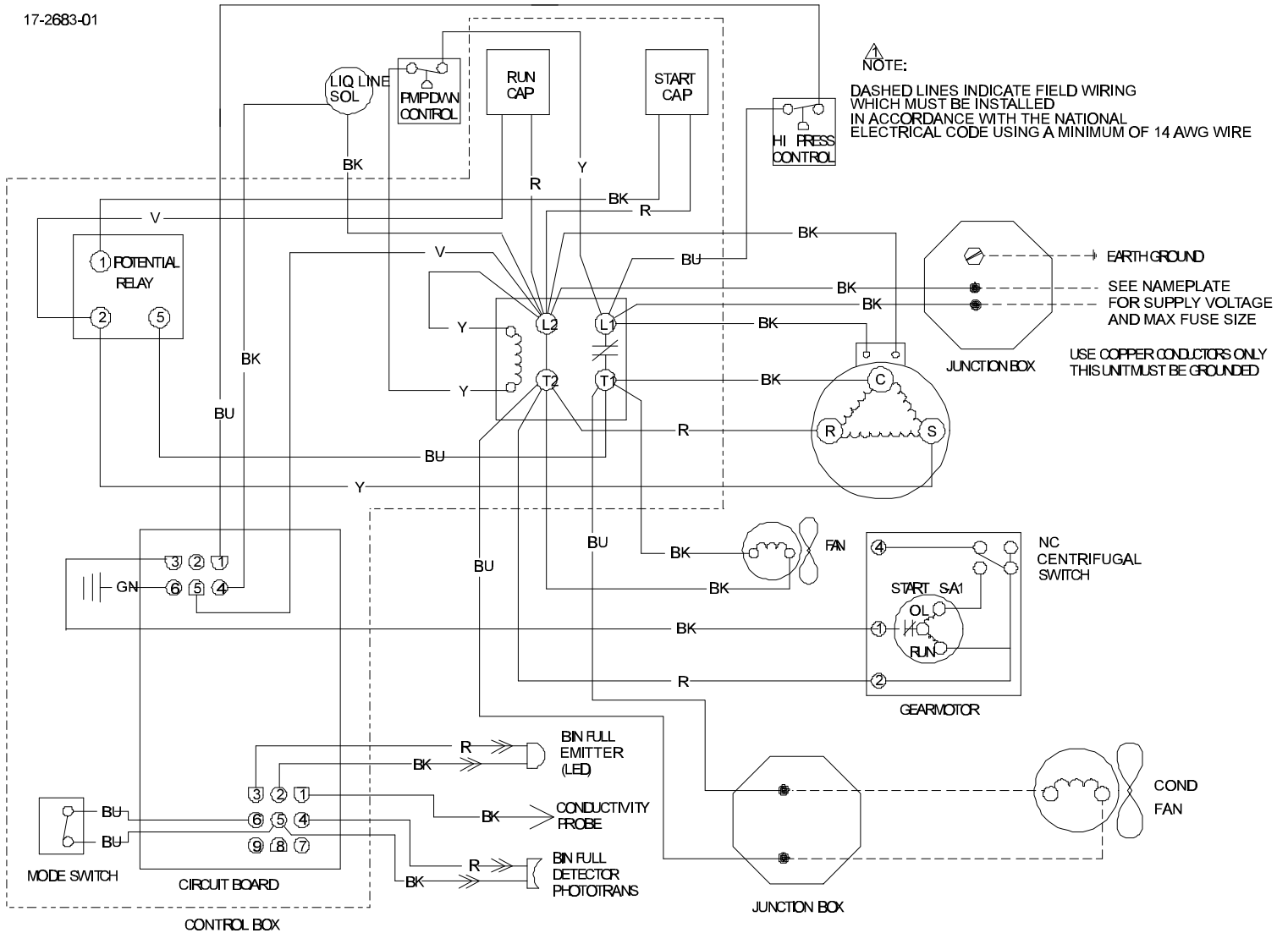

NME1254R & FME1504R SERVICE PARTS Schematic Diagram

208-230/60/1

