

# VFI

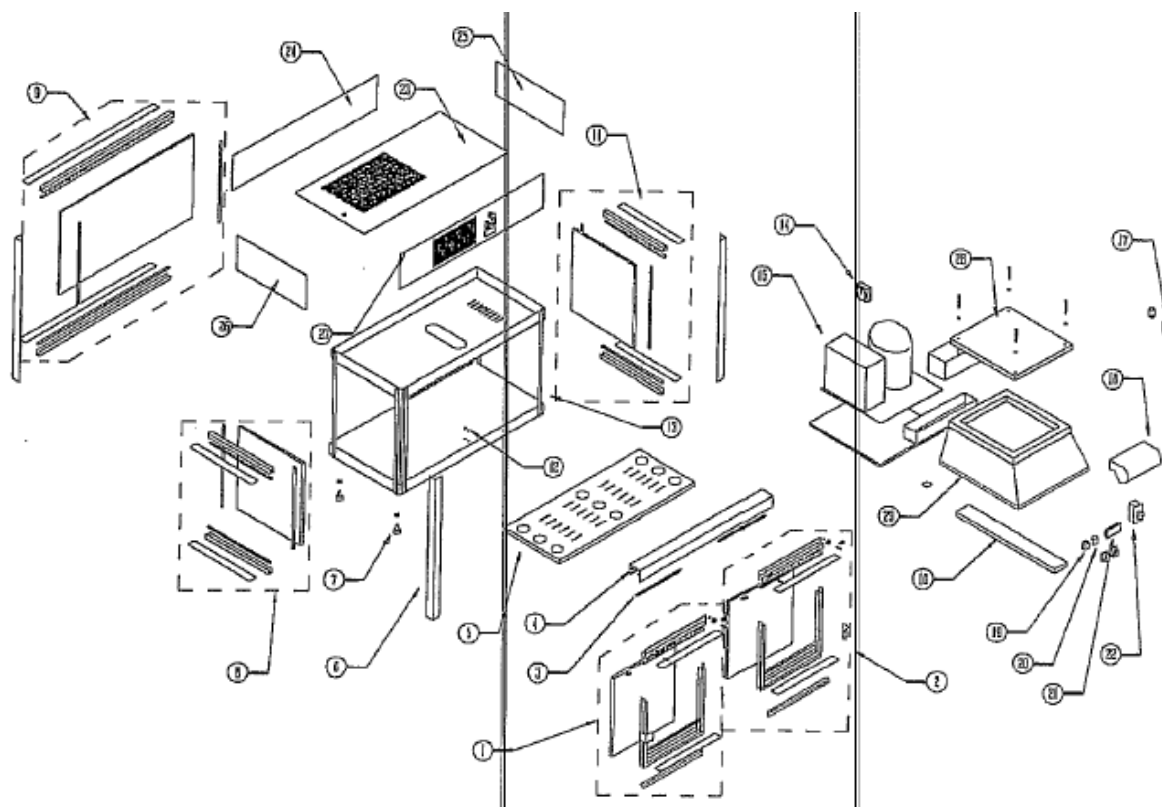

| POS. | DESCRIZIONE                    | DESCRIPTION            |
|------|--------------------------------|------------------------|
| 1    | SCORREVOLE SINISTRO            | LEFT SLIDING UNIT      |
| 2    | SCORREVOLE DESTRO              | RIGHT SLIDING UNIT     |
| 3    | MOLLA SCORREVOLI               | SPRING                 |
| 4    | BINARIO SCORREVOLI             | RACK                   |
| 5    | RIPIANO INTERMEDIO             | INTERMEDIATE SHELF     |
| 6    | PIANTONI                       | COLUMNS                |
| 7    | PIEDINI                        | FEET                   |
| 8    | VETRO LATERALE SINISTRO        | LEFT SIDE GLASS        |
| 9    | VETRO POSTERIORE               | REAR GLASS             |
| 11   | VETRO LATERALE DESTRO          | RIGHT SIDE GLASS       |
| 12   | PERNI SCORREVOLE               | PIVOTS                 |
| 13   | STRUTTURA                      | FRAME                  |
| 14   | TIMER SBRINAMENTI              | DEFROSTING TIMER       |
| 15   | GRUPPO REFRIGERANTE            | COOLING GROUP          |
| 16   | NEON                           | NEON LIGHT             |
| 17   | CAVO ALIMENTAZIONE             | CABLE                  |
| 18   | VENTOLA                        | FAN                    |
| 19   | INTERRUTTORE GRUPPO            | MAIN SWITCH            |
| 20   | INTERRUTTORE NEON              | NEON LIGHT SWITCH      |
| 21   | TERMOMETRO                     | THERMOMETER            |
| 22   | TERMOSTATO                     | THERMOSTAT             |
| 23   | COPERCHIO CARENATURA           | COVER                  |
| 24   | POSTERIORE CARENATURA          | REAR FRAME             |
| 25   | TESTATA CARENATURA             | FRAME                  |
| 26   | TESTATA CARENATURA             | FRAME                  |
| 27   | FRONTALE CARENATURA            | FRONTAL FRAME          |
| 28   | COPERCHI CASSETTA              | BOX COVERS             |
| 29   | CASSETTA VENTOLA E COMPRESSORE | COMPRESSOR AND FAN BOX |