

0107015106 Model: EKK/150

Rev. 02 - 03/01

Elektro Kippkochkessel 150 Liter

Electric tilting kettle 150 litres

Pentola rovesciabile elettrica 150 litri

Marmite basculante électrique 150 litres

Code	Beschreibung	Descrizione	Description	Désignation		SV/Qty	Start	Finish	Serianr.
3000813148	Abdeckung Wasser Schaltbl.	Protezione acqua cruscotto	Water protection control panel	Protection d'eau panneau cde	KK/KB				
3001106215	Welle Griff	Perno maniglia	Switch shaft	Tige de poignée	KK/KB	2			
3001115561	Schraube Spindelmotor	Vite attuatore	Screw spindle motor	Tige de poignée	KK/KB	1			
3006315590	Halter Feder vorne	Supporto molla anteriore	Spring holder in front	Vis de moteur basculement	KB/KB	1			
3009806853	Stift Anschlag Deckel	Perno battuta coperchio	Cover thrust pin	Support de ressort avant	KB/KB	1			
3017215110	Düse Wassereinlauf	Ugello entrata acqua	Water entry jet	Goupilla butée de couvercle	KB/50/90	2			
3027615533	Hülse Schraube Spindelmotor	Boccola vite attuatore	Bush screw spindle motor	Gicleur pour alimentation d'eau	Eco/System	1			
3027615534	Hülse Schraube Feder	Boccola vite molla	Bush screw spring	Manchon vis moteur	KB/KB	1			
3500515329	Rohr Ablauf Mitte	Tubo scarico centrale	Middle drain tube	Manchon vis ressort	KB/KB	1			
3506315939	Halter Welle Wanne	Supporto asse vasca	Shaft holder basin	Tuyau de vidange central	System-BF	1			
3560510386	Anschlussklemme	Morsetteria	Connection terminal	Support d'axe de cuve	KK/150-250	1			
4551207219	Winkelgelenk	Raccordo gomito girevole	Angle joint	Borne de raccordement	4P PA/76 Sez-6	3			
5000515806	Rohr Wassereinfuhr	Tubo erogazione acqua	Water supply tube	Raccord coudé pivotant	26 421 R 1/2"	1			
5000804444	Abdeckung Auslauf	Protezione scarico	Drain protection	Tuyau d'alimentation d'eau	EKK	1			
5001014947	Anschlag Endschalter unten	Battuta finecorsa inferiore	Stopper limit switch below	Protection de vidange	1 1/2" KK	1			
5001014949	Anschlag Endschalter oben	Battuta finecorsa superiore	Stopper limit switch above	Butée interrupteur fin de c. bas	KB/KB	1			
5001109863	Welle Deckelhub Mitte	Asse alzacoperchio centrale	Central shaft cover lifting	Butée interrupteur fin de c. haut	KB/KB	1			
5001109864	Welle Feder innen	Asse molla interna	Spring shaft inside	Axe levage du couvercle cen.	GNK/150-230	1			
5001109865	Welle Feder aussen	Asse molla esterna	Spring shaft outside	Axe de ressort intérieur	GNK/150-230	1			
5001109945	Welle Deckelhub links	Asse alzacoperchio sinistro	Left shaft cover lifting	Axe de ressort extérieur	GNK/150-230	2			
5003012322	Distanzstück Nippel Auslauf	Distanziale nipplo scarico	Spacer block drain nipple	Axe levage du couvercle gauche	ESK/GSK/DSK	2			
5003115973	Deckel doppelwandig	Coperchio + controbombato	Double walled cover	Pièce interc. raccord fil. vidange	1 1/2"	1			
5003116222	Deckel Druckwächter	Coperchio pressostato	Cover pressure control device	Couvercle à double paroi	EKK/150-250	1			
5004709717	Feder Deckelhub links	Molla alzacoperchio sinistra	Left spring cover lifting	Couvercle pressostat	TPG/80	1			
5004709718	Feder Deckelhub rechts	Molla alzacoperchio destra	Right spring cover lifting	R ressort - levage couvercle g.	GNK/150-230	1			
5004715274	Zugfeder Kipper	Molla reazione brasiera	Driving spring tilting	R ressort levage couvercle droite	GNK/150-230	1			
5005607080	Griff Deckel	Maniglia coperchio	Cover handle	R ressort de traction basculement	KB/150	1			
5006310539	Halter Feder	Supporto molla	Spring holder	Poignée de couvercle	M 10 KSK	1			
5008505691	Kugellager	Cuscinetto a sfera	Ball bearing	Support de ressort	Inox M 10	1			
5008914662	Lager Deckelhub links	Supporto coperchio sinistra	Left cover bearing	Roulement à billes	6016-2RS	2			
5008914664	Lager Deckelhub rechts	Supporto coperchio destra	Right cover bearing	Palier de couvercle gauche	SK/KS/KB	2			
5012012412	Scharnier Platte	Piastra cerniera	Plate hinge	Palier de couvercle droite	ESK/GSK/100	3			
5017309716	Silikonichtung	Guarnizione anello silicone	Silicon sealing ring	Charnière de plaque	EKK/150-250	1			
5017313787	Dichtung Manometer	Guarnizione manometro	Manometer seal	Bague d'étanchéité en silicone	D=18/16x0,5	3			
5017314030	Dichtung Schaltknopf	Guarnizione manopola	Switch seal	Joint d'étanchéité manomètre		1			
5017315500	Dichtung Einfassung	Guarnizione piano	Seal top	Joint de bouton de commande	VA 60	2			
5017316243	Beilagscheibe Entleerhahn	Rondella rubinetto scarico	Washer for pet cock	Joint plan de cuisson	System	0,95			
5017323620	Dichtung Sicherheitsentleerha.	Guarnizione rubinetto scarico	Pet safety cock seal	Rondelle pour robinet de vidange	1 1/2"	1			
5018013159	Sicherheitsentleerhahn	Rubinetto scarico	Pet safety cock	Joint de robinet de vidange	1 1/2"	1			
5018015600	Einbau Sicherheitsventil	Valvola di sicurezza interna	Internal safety valve	Robinet de vidange	1 1/2"	1			
5018106153	Elektroventil 1/2"	Electrovalvola 1/2"	Electric valve 1/2"	Soupape de sûreté intérieure	3/4"	1			
5018114399	Rückschlagventil	Valvola di ritegno	Return valve	Electrovanne 1/2"	KMG/KME/50	1			
				Soupape de retenue	Roma 1/2"	2			

SYSTEM 900

ambach

5018117567	Kondensabscheider	Scaricatore di condensa	Condense drainage	Vidange condensât	1/2"	1
5018611265	Schalttaster	Pulsantiera	Push button	Commutateur	KB/50/90	2
5022210634	Rosette	Ghiera	Round plate	Rosace	1 1/2" KK	1
5022212341	Rosette für Entleerhahn	Ghiera per rubinetto scarico	Round plate for pet cock	Rosace pour robinet de vidange	1 1/2"	1
5022914031	Schaltknopf Elektro	Manopola elettrica	Electric knob	Commutateur électrique	S/90	2
5022914336	Knebelscheibe Eit.	Anello manopola elt.	Tommy disk electric	Rondelle de poignée électrique	0-1-2-3	1
5022914340	Knebelscheibe Eit.	Anello manopola elt.	Tommy disk electric	Rondelle de poignée électrique	0-8	1
5024550861	Standsäule	Colonnina	Column	Colonne d'eau	KWC24.41.33	1
5024608002	Wasserschlauch	Tubo acqua	Water tube	Tuyau d'eau	GPG/GPK/GUK	0,7
5024610547	Silikon Schlauch	Tubo silicone	Silicone tube	Tuyau en silicone	D=5mm>8mm	0,8
5024610572	Wasserschlauch	Tubo acqua	Water tube	Tuyau d'eau	ø10mm	1
5024612522	Flexibler Stahlschlauch	Tubo flessibile	Flexible steel tube	Tuyau flexible en acier	1/4" M-M L=900	1
5024612525	Flexibler Stahlschlauch	Tubo flessibile	Flexible steel tube	Tuyau flexible en acier	1/2" M-W L=900	1
5024612526	Flexibler Stahlschlauch	Tubo flessibile	Flexible steel tube	Tuyau flexible en acier	1/2" M L=900	2
5024612563	Dampfschlauch	Tubo vapore	Steam tube	Tuyau vapeur	3/4" L=310	1
5024709751	Pilot Heizkörper	Resistenza controllo acqua	Heating element pilot	Résistance double enveloppe	KSK/150-200	1
5027210517	Manometer	Manometro	Manometer	Manomètre	0-1bar ESK/GSK	1
5028509493	Rohrschelle	Fascetta per tubo	Pipe clamp	Collier de serrage pour tuyau	D=32-50/13 W1	1
5028510548	Schlauchschele	Fascetta stringitubo	Pipe clamp	Collier de serrage de tuyau	ø7,5>9mm	2
5028510569	Rohrschelle	Fascetta per tubo	Pipe clamp	Collier de serrage pour tuyau	D=22/9 W1	2
5040003847	Nutmutter	Ghiera di bloccaggio	Groove nut	Ecrou cylindrique à encoches	M 80x2	2
5040209715	Befestigungsschelbe	Rondella fissaggio	Fastening washer	Rondelle de fixation	D=26 Di=15	3
5040310957	Mutter 6kt autobl.	Dado esa. autobloccante	Hexagon screw autobl.	Ecrou hexagonal autobloquant	M12 Inox 18/8	2
5040412194	Nutmutter Innox	Dado es. cleco inox	Hexagonal nut inox	Ecrou borgne en inox	KSK/150 M20x1,5	2
5041010377	Schraube 6kt	Vite ta esagonale	Hexagon screw	Vis hexagonale	M 12x50 Innox	1
5041402628	Zylinderschraube in. 6kt	Vite lcai	Hexagon cylinder screw	Vis cylindrique hexagonale	M 8x20 Innox	20
5041810579	Zylinderspezialschraube	Vite lo cava es.	Hexagon cylinder screw	Vis à tête cylindrique spéciale	8x30 M6	2
5050101267	Bogen Messing	Gomito ottone	Elbow brass	Raccord coudé en laiton	M+W 1/2" Art.458	6
5050120029	Bogen + Holländer	Gomito ottone	Elbow brass	Raccord coudé	R19 - 1/2"	1
5050120702	Bogen Messing	Gomito ottone	Elbow brass	Raccord coudé en laiton	Fig. 90 - 3/4"	1
5050909752	Schützenskörfilter	Filtro antidi disturbo	Radioshielding filter	Filtre antiparasites	TPE/KSK	1
5050912346	Schützenskörfilter	Filtro antidi disturbo	Radioshielding filter	Filtre antiparasites	130/240 V	5
5050915915	Filter in Messing	Filtro in ottone	Brass filter	Filtre en laiton	1/2"	1
5051001287	Doppelnippel	Nipplo doppio	Double nipple	Double raccord	MS 1/2" Art.441	1
5051013297	Nippel Auslauf	Nipplo scarico	Drain nipple	Raccord fileté de vidange	EKK/150-250	1
5051210544	Schlauchverschraubung	Portagomma cilindrico	Flexible tube connection	Raccord fileté de flexible	1/2">ø12	2
5051210546	Schlauchverschraubung	Portagomma cilindrico	Flexible tube connection	Raccord fileté de flexible	1/4">ø7	2
5051220023	Rohrverschraubung Messing	Raccordo ottone	Brass pipe union	Raccord vissé en laiton	1/2">16	3
5051310364	Reduzierung Messing	Riduzione ottone	Brass adapter	Douille de réduction en laiton	1/2">1/4" Art.448	1
5060508821	Anschlussklemme	Morsetiera	Connection terminal	Borne da raccordement	PA/44 Sez.4	1
5060513981	Universalklemme grau	Morsetto universale grigio	Grey universal terminal	Borne universelle grise	6QMM	3
5060513982	Universalklemme grau	Morsetto universale grigio	Grey universal terminal	Borne universelle grise	16QMM	3
5060513984	Null-Leiterklemme blau	Morsetto neutro blu	Blue neutral terminal	Borne neutre bleue	6QMM	1
5060513985	Null-Leiterklemme blau	Morsetto neutro blu	Blue neutral terminal	Borne neutre bleue	16QMM	1
5060513987	Erdungsklemme gelb/grün	Morsetto terra giallo/verde	Yellow/green ground terminal	Borne de terre jaune/verte	6QMM	1
5060513988	Erdungsklemme gelb/grün	Morsetto terra giallo/verde	Yellow/green ground terminal	Borne de terre jaune/verte	16QMM	1
5060809979	Heizkörper 8000W	Resistenza 8000W	Heating element 8000W	Résistance 8000W	KKE (IRCA)	2

5060810064	Heizkörper 6000W	Resistenza 6000W	Heating element 6000W	Résistance 6000W	KKE (IRCA)	1
5060904035	Stufenschalter	Commutatore	Step switch	Commutateur à gradins	4T. KKE	1
5060909440	Anfahrrolle	Rotella + finecorsa	Starting pulley	Galet d'entraînement	ø13 mm AR-ATO	2
5060909748	Endschalter ATO-11-2-i	Finecorsa ATO-11-2-i	Limit switch ATO-11-2-i	Interrupteur fin de c. ATO-11-2-i	K&M	2
5060909759	Motorschutzschalter	Disgiuntore termico	Motor protection switch	Disjoncteur protection moteur	E-T-A 1A	1
5060911266	Schaltkontakt	Contatto cerna	Switch push button contact	Interrupteur contact	KB/50/90	2
5061109898	Signalleuchte gelb	Lampada spia gialla	Yellow control lamp	Voyant lumineux jaune	230V T150°C	1
5061111121	Signalleuchte weiß	Lampada spia bianca	White control lamp	Voyant lumineux blanc	230V T150°C	1
5061113846	Signalleuchte grün	Lampada spia verde	Green control lamp	Voyant lumineux vert	230V	1
5081211324	Kondensator MFL	Condensatore MFL	Condenser MFL	Condensateur MFL	250V 6,3uF	1
5061214563	Spindelmotor	Attuatore	Spindle motor	Moteur actionnement de bascul.	Calr33 300mm	1
5061214600	Gabel für Spindelmotor	Forcella anteriore	Force for spindle motor	Fourche moteur de bascule.	Calr33	1
5061315480	Druckwächter Dampfüberwach.	Pressostato controllo vapore	Pressure switch steam control	Pressostat - contrôle de vapeur		1
5061407226	Schütz CGE	Contattore CGE	Contacteur CGE	Contacteur-disjoncteur CGE	CL25A300T6AM	2
5061411123	Schütz CGE	Contattore CGE	Contacteur CGE	Contacteur-disjoncteur CGE	CL02A400TAM	3
5061600808	Sicherheitsthermostat	Termostato limitatore	Safety thermostat	Thermostat de sécurité	KSKE	1
5061609772	Thermostat Wasserfüllung	Termostato controllo livello	Thermostat water control	Thermostat contrôle niveau eau	KSK	1
5061616087	Energieregler	Regolatore d'energia	Energy controller	Doseur d'énergie	230V 12A	1
5061807908	Sicherungshalter	Porta fusibile	Fuse holder	Porte-fusible	Siemens	1
5061809773	Sicherung 8A	Fusibile 8A	Fuse 8A	Fusible 8A	TPME/KKME	2
5003012322	Distanzstück Nippel Auslauf	Distanziale nipplo scarico	Spacer block drain nipple	Pièce interc. raccord fil. vidange	1 1/2"	1 20/03/01 799564

SYSTEM 900 + BF

ELEKTRO SCHALTPLAN
WIRING DIAGRAM

SCHEMA ELETTRICO
SCHEMA ELECTRIQUE



EKK/150

EKK/150-BF

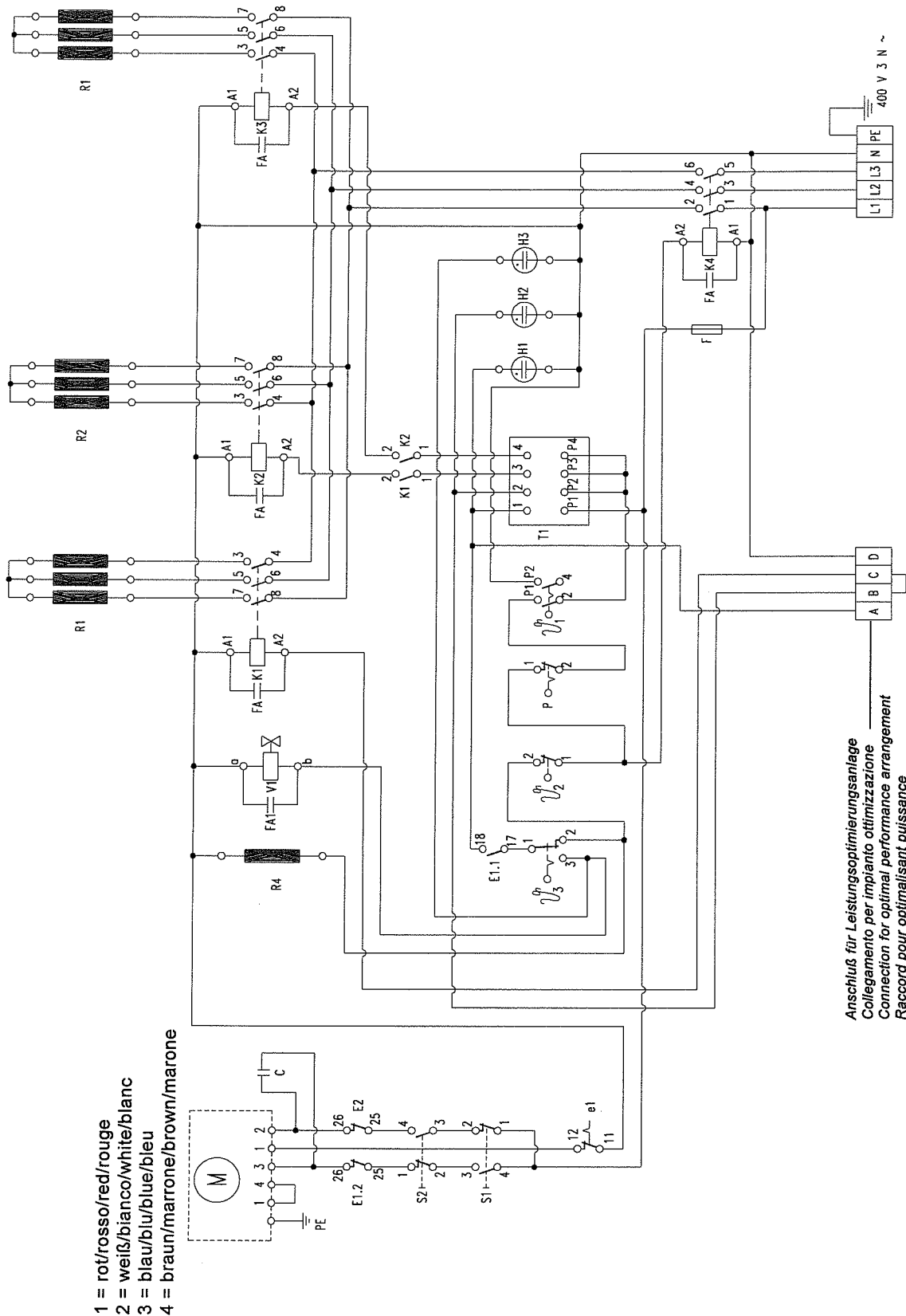

- 1 = rot/rosso/red/rouge
- 2 = weiß/bianco/white/blanc
- 3 = blau/blu/blue/bleu
- 4 = braun/marrone/brown/marone

Anschluß für Leistungsoptimierungsanlage
Collegamento per impianto ottimizzazione
Connection for optimal performance arrangement
Raccord pour optimisation puissance

Code 5434564875V
Seite 1 von 3

Gezeichnet
Disegnato

Zohani

Geprüft
Controllato

Müller

Datum 21/12/00
Data

System-Kippkessel

SYSTEM 900 + BF

ELEKTRO SCHALTPLAN
WIRING DIAGRAM

SCHEMA ELETTRICO
SCHEMA ELECTRIQUE



EKK/150 EKK/150-BF

g₁	Energieregler (230 V - 12 A) Regolatore d'energia (230 V - 12 A) Regulator of energy (230 V - 12 A) Régulateur d'énergie (230 V - 12 A)	} Ambach Code 5061616087
g₂	Sicherheits-Temperaturbegrenzer 150° C Termostato di sicurezza (riarmo manuale) 150° C Safety thermostat (manual resetting) 150° C Thermostat de sécurité (rearmement manuel) 150° C	} Ambach Code 5061600808
g₃	Thermostat Regulierung Wasserniveau Doppelmantel Termostato regolazione livello acqua intercapedine Thermostat regulation water level double interspace Thermostat régulation niveau d'eau double enveloppe	} Ambach Code 5061609772
e1	Schutzschalter Motor Interruttore protezione motore Protection switch motor Interrupteur protection moteur	} Ambach Code 5060909759
V1	Ventil Wasserfüllung Doppelmantel Valvola riempimento acqua intercapedine Valve water filling double interspace Soupape remplissage d'eau double enveloppe	} Ambach Code 5018106153
P	Druckwächter Pressostato Pressure control device Pressostat	} Ambach Code 5061315480
T1	Stufenschalter mit 4 Positionen Commutatore con 4 posizioni Step switch with 4 positions Commutateur avec 4 positions	} Ambach Code 560904035
K1-3	Schalterschütz Contattore Contactor Contacteur	} Ambach Code 5061411123
K4	Hauptschütz Contattore principale Main contactor Contacteur principal	} Ambach Code 5061407226
H1	Weißer Kontrolleuchte Gerät "in Funktion" 230 V (Betriebslampe) Lampada controllo bianca apparecchio "in funzione" 230 V (tensione in linea) White control lamp appliance "on function" 230 V (operating lamp) Voyant lumineux blanc de fonctionnement de appareil 230 V (lampe-témoin)	} Ambach Code 5061111121
H2	Gelbe Kontrolleuchte Heizung "in Funktion" 230 V (Thermostatlampe) Lampada controllo gialla riscaldamento "in funzione" 230 V (lampada termostato) Yellow control lamp heating "on function" 230 V (thermostat lamp) Voyant lumineux jaune de fonctionnement de chauffage 230 V (lampe-témoin)	} Ambach Code 5061109898
H3	Grüne Kontrolleuchte Wasserfüllung "in Funktion" (230 V) Lampada controllo verde riempimento acqua "in funzione" (230 V) Green control lamp water filling "on function" (230 V) Voyant lumineux vert du mécanisme de remplissage de la double enveloppe (230 V)	} Ambach Code 5061113846
F	Sicherung 8 A / 250 V (Flink) Fusibile 8 A / 250 V (rapido) Fuse 8 A / 250 V (quick acting) Fusible 8 A / 250 V (action instantanée)	} Ambach Code 5061809773

Code **5434564875V-a**
Seite 2 von 3

Gezeichnet
Disegnato *Z. Shani*

Geprüft
Controllato *M. Müller*

Datum
Data 21/12/00

System-Kippkessel

SYSTEM 900 + BF

ELEKTRO SCHALTPLAN
WIRING DIAGRAM

SCHEMA ELETTRICO
SCHEMA ELECTRIQUE



EKK/150 EKK/150-BF

- | | | |
|-------------|--|--|
| M | Kippmotor 0,18 kW / 230 V (CATR33 300 mm)
Motore di ribaltamento 0,18 kW / 230 V (CATR33 300 mm)
Tilting motor 0,18 kW / 230 V (CATR33 300 mm)
Moteur basculement 0,18 kW / 230 V (CATR33 300 mm) | } Ambach Code
5061214563 |
| C | Kondensator 6,3 μ f
Condensatore 6,3 μ f
Condenser 6,3 μ f
Condensateur 6,3 μ f | } Ambach Code
5061211324 |
| E2 | Endschalter Kessel gekippt
Fine corsa pentola inclinata
Limit switch pan tilted
Fin de course marmite basculée | } Ambach Code
5060909748 + 5060909440 |
| E1.1 | Endschalter Heizung
Fine corsa impianto riscaldamento
Limit switch heating
Fin de course chauffage | } Ambach Code
5060909748 + 5060909440 |
| E1.2 | Endschalter Kessel waagrecht
Fine corsa pentola in piano
Limit switch pan horizontal
Fin de course marmite horizontal | } Ambach Code
5060909748 + 5060909440 |
| S1 | Taster heben
Tasto alzare
Key lifting
Bouton soulever | } Ambach Code
5018611265 + 5060911266 |
| S2 | Taster senken
Tasto abbassare
Key lower
Bouton abaisser | } Ambach Code
5018611265 + 5060911266 |
| R4 | Heizkörper Kontrolle Wasserniveau Doppelmantel 230 V
Resistenza controllo livello acqua intercapedine 230 V
Heating element water level control double interspace 230 V
Résistance contrôle niveau eau double enveloppe 230 V | } Ambach Code
5024709751 |
| R1 | Heizkörper 8000 W / 230 V
Resistenza 8000 W / 230 V
Heating element 8000 W / 230 V
Résistance 8000 W / 230 V | } Ambach Code
5060809979 |
| R2 | Heizkörper 6000 W / 230 V
Resistenza 6000 W / 230 V
Heating element 6000 W / 230 V
Résistance 6000 W / 230 V | } Ambach Code
5060810064 |
| FA1 | Schützentstörfilter 400 V
Filtro antidisturbo 400 V
Antiparasitic filter 400 V
Filtre antiparasites 400 V | } Ambach Code
5050909752 |
| FA | Schützentstörfilter 130/240 V
Filtro antidisturbo 130/240 V
Antiparasitic filter 130/240 V
Filtre antiparasites 130/240 V | } Ambach Code
5050912346 |

Code **5434564875V-b**
Seite 3 von 3

Gezeichnet
Disegnato *Z. Lohani*

Geprüft
Controllato *M. Müller*

Datum
Data 21/12/00

System-Kippkessel